



Partnerships
Built on Trust

SAFETY & HEALTH MANUAL



2024

 Partnerships Built on Trust	Table of Contents	Page 1
	Revision Date: 1/8/2024	Updated
SAFETY & HEALTH MANUAL		

- 1. Overview and Responsibilities
 - Introduction.....
 - Statement of Safety Policy
 - Responsibilities for Safety
- 2. Rules and Disciplinary
 - Basic Rules of Safety & Conduct.....
 - Disciplinary Action for Safety Violations
 - Drug & Alcohol Policy
- 3. Emergency Action Plans.....
 - Emergency Procedures
 - Medical & First Aid Program
 - Jobsite Fire Protection
 - Reporting Work Related Injuries & Return to Work Program.....
 - Reporting Motor Vehicle Accidents.....
- 4. Health Hazards.....
 - A. Hearing Conservation and Protection.....
 - B. Respiratory Protection Program
 - C. Blood-borne Pathogens- Exposure Control Plan
 - D. Silica Dust Program
 - E. Hazard Communication Program
 - F. Lead Program.....
- 5. Chemical Storage and Safety
- 6. Personal Protective Equipment
- 7. Electrical
- 8. Scaffolding Safety
- 9. Aerial Lift Safety
- 10. Mobile Crane & Rigging Safety.....
- 11. Fall Protection Requirements
- 12. Excavation Safety Procedures.....
- 13. Ladders & Stairs
- 14. Lockout-Tagout Program
- 15. Confined Space Entry Program
- 16. Forklift & Industrial Lift Safety
- 17. Hot Work Operations
- 18. Safety Training

 - Ongoing & Specialized Safety Training

- 19. Safety Inspections

 - Work Area & Jobsite Safety Inspections.....
 - Handling OSHA Inspections

- 20. OSHA Inspection

 Partnerships Built on Trust	Table of Contents	Page 2
	Revision Date: 1/8/2024	Updated
SAFETY & HEALTH MANUAL		

- 21. Fleet Safety Program.....
 - Responsibilities.....
 - Defensive Driving
 - Eligibility
 - Accidents.....
 - Vehicle Loading.....
 - Vehicle Maintenance
- 22. Forms
- A. Employee Acknowledgement of Safety Rules
- B. Employee Notification of Safety Violation
- C. Subcontractor Confirmation of Non-Compliance with Safety and Health Standards
- D. Beeler Employee Injury Form
- E. Non-Employee/Subcontractor Injury Form
- F. Supervisor’s Catastrophe Investigation/Employee Injury Form
- G. Daily Site Safety Inspection.....
- H. Monthly Jobsite Safety Inspection
- I. OSHA Inspection Checklist.....
- J. OSHA Inspection Report
- K. Confined Space Permit.....
- L. Hot Work Permit
- M. Site Specific Silica Respirable Crystalline Silica Exposure Control Plan
- N. Compact/Track Loader (aka skid steer) Pre-use Inspection Checklist
- O. BPSA (Beeler Project Safety Assessment)

 Partnerships Built on Trust	1. Overview & Responsibilities	Page 1
	Revision Date: 1/8/2024	Updated
SAFETY & HEALTH MANUAL		

INTRODUCTION

Beeler Construction is committed to the safety of all team members - employees, subcontractors, and the general public. This commitment is demonstrated through investment in, and maintenance of, equipment, processes, and ongoing employee safety training.

While the main objective of the Beeler Construction safety program is to eliminate or minimize hazards to prevent accidents and injuries; not all hazards can be eliminated. Whenever and wherever employees work, there is always the possibility of error therefore observation and enforcement of safety rules and regulations is required.

The purpose of this Safety Manual is to communicate these basic safety rules and programs to all Beeler Construction employees and subcontractors. Your role may be covered by more specific requirements and procedures that are not necessarily detailed in this manual. If you are not familiar with these specific requirements, ask your foreman or superintendent.

These safety rules and requirements form the basis of the Beeler Construction comprehensive safety program that is designed to prevent, reduce, and minimize the tragic effects of accidents and injuries. Your responsibility, as a valued team member (employee) of Beeler Construction, is to read and become familiar with this information. Failure to follow these safety rules, in addition to other specific procedures, can result in disciplinary action, including possible termination of employment.

The management of Beeler Construction values your personal safety and your contribution to the overall safety program. For this safety program to be successful, you must become an active participant. Use the information contained in this manual and apply the training that you receive in your everyday activities. Thank you for helping to make Beeler Construction a safe workplace environment.

 Partnerships Built on Trust	1. Overview & Responsibilities	Page 2
	Revision Date:1/8/2024	Updated
SAFETY & HEALTH MANUAL		

Statement of Safety Policy

The employees of Beeler Construction are the company's most valuable resources. Our purpose: TO PROVIDE REWARDING CAREERS THROUGH OUR PASSION FOR BUILDING RELATIONSHIPS. We strive to live by our core values: RELATIONSHIPS AT EVERY LEVEL, DO WHAT'S RIGHT NOT WHAT'S EASY, LEAD WITH A CAN-DO ATTITUDE, COMMITTED TO EXCELLENCE. An integral part of living these values is providing a safe and healthful workplace for all team members through the establishment of safety rules, procedures, and programs that are strictly and uniformly enforced at all locations and work sites. It is also the intent of Beeler Construction to comply with all federal, state, and local safety standards, codes, and regulations.

**Chad Beeler, COO
Beeler Construction, Inc.**

**Dave Beeler, President
Beeler Construction, Inc.**

**Kim Peterson, CFO
Beeler Construction, Inc.**

 SAFETY & HEALTH MANUAL	1. Overview & Responsibilities	Page 3
	Revision Date: 1/8/2024	Updated

BEELER'S SAFETY POLICY AT A GLANCE

EVERYONE is responsible for safety. At Beeler, this is accomplished through a team effort. There are levels of responsibility which help incorporate Beeler's Safety Program; they are outlined below:

Role	Responsibility
Management/Safety Director	Ensure and execute safety program by enforcing, updating, and educating the Beeler team.
Project Coordinators, Assistant Project Managers, Project Managers, and all other office team members	Incorporate the established safety policies and standards into the projects from bid to completion.
Foreman/Superintendents	Ensuring the safety program is carried out in the field by all personnel including Beeler team members as well as subcontractors and ensuring the jobsite and surroundings are safe for everyone.
Field Team Members and ALL team members (all employees)	Ensuring the safety program is carried out by safely performing assigned tasks.

 Partnerships Built on Trust	1. Overview & Responsibilities	Page 4
	Revision Date:1/8/2024	Updated
SAFETY & HEALTH MANUAL		

Employee Safety Policy Key Points

General	Use common sense, work within your abilities, and ask if you are not sure. The only bad question is the one never asked.
Reporting	No matter how minor it seems, always report an injury.
Tools	Keep all guards in place, use the tool as intended, and do NOT use a defective tool. All users must be trained on proper use of tool before use.
PPE	Safety glasses, proper footwear, & hardhats 100% of the time at all job sites, high visibility anytime exposed to public traffic at a minimum.
Fall Protection (Comply with OSHA 29CFR 1926 subpart M)	Supervisor will help determine what means to use (e.g. guard rails, safety harness, warning lines, etc.).
Electrical	Everything MUST be plugged into a GFCI , this is Beeler's Assured Grounding Program. All quarterly marking on non-grounded equipment must be performed by a qualified person.
Ladders	Inspect before use each time; use ladder as designed. If there is any question to limit or application, ask supervisor.
Scaffolding	Must be erected by a competent person. Must be inspected and recorded daily.
Hazard Communication	SDS. Use it, know it. 800.451.8346 or 760.602.8703 it is 24 hours/day-7 days/week-365 days/year.
Lifting	Use common sense. If it is too heavy get help. If mechanical assistance is needed, get it. If unsure, discuss with supervisor.
Security/protection of Tools and Equipment	Tools and equipment need to be secured to protect from theft or use by unauthorized people. This is done through gang boxes, removal of keys, and storage in secure locations.
Violations	Violations of the safety policy will be addressed through a progressive warning system. Starting with a verbal warning and progressing all the way to termination if refusal to correct the violation.

 Partnerships Built on Trust	1. Overview & Responsibilities	Page 5
	Revision Date:1/8/2024	Updated
SAFETY & HEALTH MANUAL		

Subcontractor Safety Policy Key Points

Safety Requirements	100% OSHA compliant. Beeler may also establish its own site safety & health standards that may exceed or are not addressed in OSHA's standards.
Compliance	Is ensured by Beeler foreman, superintendent, & project manager, safety director and management.
Prequalifying	Subcontractors must submit a copy of their Safety Manual for review of compliance prior to working on any Beeler Construction jobsites. Subcontractors must submit the following safety metrics that will be reviewed and will be a basis for determining subcontractor approval for working on Beeler Construction jobsites: <ul style="list-style-type: none"> ▪ TRIR Rate (Total Recordable Incident Rate) ▪ EMR Rate (Employer Modification Rating) ▪ DART Rate (Days Away/Restricted or Job Transfer Rate)
Preconstruction Meetings	When applicable, subcontractors are required to attend preconstruction meetings prior to beginning work on Beeler Construction jobsites. Topics shall include safety and compliance, job specific safety orientation, work scope, schedule, etc.
During Construction	When on site, if Toolbox Talks meetings are scheduled for Beeler Construction workers, subcontractors are required to participate. If safety meetings are planned, subcontractors are required to participate. Beeler jobsite safety inspections will evaluate all subcontractors' work practices; any violations or deficiencies will be recorded and forwarded to their office. Corrections are to be made with confirmation in writing signed off by the Beeler Construction superintendent.
Post Construction	Subcontractors' safety will be evaluated during post construction review of projects, as a part of their project closeout each subcontractor will receive performance review that will include safety and project execution.

 Partnerships Built on Trust SAFETY & HEALTH MANUAL	1. Overview & Responsibilities	Page 6
	Revision Date:1/8/2024	Updated

Responsibilities for Safety

PURPOSE: To provide employees with information regarding the Beeler Construction safety program and specific responsibilities regarding their involvement in the company's safety program.

POLICY: The employees of Beeler Construction are the company's most valuable resources. It is the policy of Beeler Construction to provide a safe and healthful workplace for all employees through the establishment of rules, procedures and programs that are strictly enforced at all jobsites and locations. It is also the intent of Beeler Construction to comply with all federal, state, and local safety standards, codes, and regulations.

▼ Responsibilities:

Management:

Overall and ultimate responsibility for this policy lies with the owners and management of Beeler Construction.

Safety Director:

The Beeler Construction Safety Director is a staff management function and is responsible for coordinating the overall safety program. The Safety Director's primary job responsibilities include:

- Administering the overall safety program for Beeler Construction.
- Establishing requirements for ongoing and specialized training for employees and management.
- Maintaining and implementing safety programs that comply with changing governmental safety standards.
- **Facilitating Incident Investigation Program**
 - Every incident is reviewed with Safety Director, Management, and Field Team
 - All incidents requiring reporting to OSHA are done within 8 hours to OSHA and to client within 24 hours.
 - Training is provided for this program at time of hire, as needed, and at a minimum annual basis.
 - All evidence from incident shall be preserved & collected to the extent possible.
 - All incidents are documented (forms section has injury forms attached).
 - A final review of incident is conducted.
 - Corrective measures to eliminate a recurrence are put in place.
 - A lessons-learned summary is put together and communicated to the entire Beeler team.

 Partnerships Built on Trust	1. Overview & Responsibilities	Page 7
	Revision Date:1/8/2024	Updated
SAFETY & HEALTH MANUAL		

Project Managers & Estimators:

Project Managers have overall responsibility for the projects they manage, including safety issues affecting Beeler Construction employees and project subcontractors. Specific safety responsibilities include:

- Assess job specific safety requirements during estimating and account for such in the estimates/proposals.
- Define necessary job specific safety requirements prior to project start-up and review these with the project foreman/superintendent.
- Ensuring that routine jobsite safety inspections are conducted.
- Communicating safety requirements to subcontractors prior to project commencement.
- Enforcing jobsite safety requirements with subcontractors.
- **Participating in Incident Investigation Program.**
 - Every incident is reviewed with Safety Director, Management, and Field Team.
 - All incidents requiring reporting to OSHA are done within 8 hours to OSHA and to client within 24 hours.
 - Training is provided for this program at time of hire, as needed, and at a minimum annual basis.
 - All evidence from incident shall be preserved & collected to the extent possible.
 - All incidents are documented (forms section has injury forms attached).
 - A final review of incident is conducted.
 - Corrective measures to eliminate a recurrence are put in place.
 - A lessons-learned summary is put together and communicated to the entire Beeler team.

Foremen/Superintendents:

Project foreman are responsible for the safe condition and operation of each jobsite managed for Beeler Construction to the extent within their control. This includes all work operations performed by Beeler Construction employees as well as all subcontractors' employees. Specific responsibilities include:

- Inspect work areas and equipment for compliance with work rules and standards.
- Evaluate all subcontractor operations for safety compliance.
- Instruct employees (including subcontractor employees) on hazards of the job, how to work safely according to operating procedures, and applicable safety regulations through periodic safety meetings.
- Ensure prompt treatment and reporting of injuries that occur to Beeler Construction employees.
- Investigation of all occupational accidents and injuries.

 Partnerships Built on Trust	1. Overview & Responsibilities	Page 8
	Revision Date:1/8/2024	Updated
SAFETY & HEALTH MANUAL		

- **Participating in Incident Investigation Program.**
 - Every incident is reviewed with Safety Director, Management, and Field Team
 - All incidents requiring reporting to OSHA are done within 8 hours to OSHA and to client within 24 hours.
 - Training is provided for this program at time of hire, as needed, and at a minimum annual basis.
 - All evidence from incident shall be preserved & collected to the extent possible.
 - All incidents are documented (forms section has injury forms attached).
 - A final review of incident is conducted.
 - Corrective measures to eliminate a recurrence are put in place.
 - A lessons-learned summary is put together and communicated to the entire Beeler team.
- Enforcement of jobsite safety rules and regulations.
- Setting the proper example for safety by observing all applicable safety rules and regulations.

Team Members (Employees):

Every Beeler Construction employee is responsible for following safety rules set forth in this safety manual and for reporting any unsafe conditions or unsafe acts that they may be aware of. Specific responsibilities include:

- Only performing jobs that they have been specifically trained to do.
- Following prescribed safety rules and regulations.
- Using required personal protective equipment.
- Reporting all unsafe conditions or practices.
- Reporting all injuries, no matter how minor.
- **Participating in Incident Investigation Program.**
 - Every incident is reviewed with Safety Director, Management, and Field Team
 - All incidents requiring reporting to OSHA are done within 8 hours to OSHA and to client within 24 hours.
 - Training is provided for this program at time of hire, as needed, and at a minimum annual basis.
 - All evidence from incident shall be preserved & collected to the extent possible.
 - All incidents are documented (forms section has injury forms attached).
 - A final review of incident is conducted.
 - Corrective measures to eliminate a recurrence are put in place.
 - A lessons-learned summary is put together and communicated to the entire Beeler team.
- Cooperate during the investigation of any accidents that occur.

 Partnerships Built on Trust	1. Overview & Responsibilities	Page 9
	Revision Date:1/8/2024	Updated
SAFETY & HEALTH MANUAL		

Violations of Safety Rules or Company Safety Policies:

Company safety rules and safety policies are necessary to prevent accidents and injuries from occurring. Safety rules and policies will be strictly enforced. Enforcement will be in the form of disciplinary action which will consider the seriousness of the violation. Serious violations of safety rules may result in unpaid time off or termination of employment. Minor violations may result in written warnings to employees. Repeat minor violations may result in unpaid time off, or in termination of employment. Specifics regarding Beeler Construction's disciplinary action program are found in the Disciplinary Action section of the safety manual.

 SAFETY & HEALTH MANUAL	Partnerships Built on Trust	2. Rules & Disciplinary	Page 1
		Revision Date: 1/8/2024	Updated

Basic Rules of Safety & Conduct

PURPOSE: This procedure provides general and specific company safety rules that apply to all employees, and specific jobs and activities performed by Beeler Construction. All employees are to be provided with a copy of these safety rules that will be enforced by their foreman or superintendent and management.

POLICY: Beeler Construction provides a safe and healthful workplace for all of its employees and subcontractors. Safety rules have been developed to ensure that each employee works in a safe manner. Violations of the safety rules that follow, or any other generally accepted safety practice, will result in disciplinary action.

TRAINING: All Beeler Construction employees shall receive initial training on the basic rules of safety and conduct, refresher training is provided periodically thereafter. Training shall be documented with the employee's name, date of training and name of trainer recorded.

SAFETY RULES:

▼ General and Specific Safety Rules:

General Safety Rules:

- 1) All employees must understand their work assignment and the associated hazards before starting a job. Any questions concerning the job or safety hazards must be directed to a foreman or superintendent.
- 2) Employees must report all accidents and injuries, no matter how minor, immediately to their foreman or superintendent, and must report the injury to the office.
- 3) All unsafe conditions and equipment and unsafe acts must be reported immediately to a foreman or superintendent and must be documented in the Daily Report.
- 4) Employees must attend scheduled safety training sessions and safety meetings.
- 5) It is the intent of management to distribute Tool Box Talks and or similar safety information to the employee's bi-monthly. Employees are to read the information and sign the acknowledgement receipts and return the signed receipts to the office. Employees are also requested to maintain a library/file of all safety handouts for their reference.
- 6) Horseplay or fighting on the job is a serious safety violation and will not be tolerated at any time.

 <p>Partnerships Built on Trust</p> <p>SAFETY & HEALTH MANUAL</p>	<p>2. Rules & Disciplinary</p>	<p>Page 2</p>
	<p>Revision Date: 1/8/2024</p>	<p>Updated</p>

- 7) Possession or working under the influence of alcohol or illegally obtained controlled substances during work will not be tolerated and may result in immediate termination.
- 8) Possession of firearms is not allowed and may result in immediate termination.
- 9) Running on the job is prohibited, except in cases involving emergencies where prompt evacuation is required.
- 10) Employees shall observe and comply with all caution and danger signs, barricades and safety tags at the jobsite.
- 11) Employees shall practice good housekeeping practices in their work area by properly and routinely disposing of scrap materials and waste to prevent an unsafe accumulation of trash at the jobsite. As a general rule all work is to be cleaned on a daily basis.
- 12) Compressed air shall not be used for dusting off or cleaning off their body or clothing.
- 13) Employees are required to report to their foreman or superintendent immediately any problem or defects present in tools and equipment that they are using or responsible for. These tools are to be subsequently tagged by the foreman, removed from the jobsite and returned to the office for repairs.
- 14) Beeler Construction employees shall wear hard hats **AT ALL TIMES** on an active worksite. This includes management, office staff, drivers, and others that may be on site.
- 15) Appropriate footwear shall be worn by all employees. Footwear shall consist of a substantial leather shoe or boot that protects the foot from injury as a result of incidental contact with falling tools or materials as well as providing proper ankle support.
- 16) Shorts and sleeveless shirts are not allowed. Long pants and shirts are required. Any employee reporting for work without **appropriate footwear** and clothing **WILL BE SENT HOME.**
- 17) Head & Eye protection must be worn **AT ALL TIMES** on an active worksite.
- 18) Employees shall use all guards, tools, and safety devices provided to prevent injury. This includes shields, guards, interlocks, etc. on machinery and equipment such as grinders, saws, cutting equipment, etc. Removal or manipulation of any safety guards is considered a serious OSHA violation.
- 19) All employees have a responsibility to protect the general public and provide for their safety. The safety of the public is as equally important as the safety of our employees.

Injury & Accident Reporting:

- 1) It is the responsibility of all employees to immediately report to their foreman or superintendent the occurrence of any work-related injury or illness, no matter how minor the injury may seem.
- 2) The first priority is to ensure that the injured employee receives the appropriate first aid or medical treatment. The foreman or superintendent will then determine the level of medical assistance necessary. The foreman or superintendent will

 Partnerships Built on Trust	2. Rules & Disciplinary	Page 3
	Revision Date: 1/8/2024	Updated

- then determine if the employee will be transported for treatment via ambulance or company vehicle.
- 3) The foreman or superintendent must then contact the company office as soon as possible to report the injury, no matter how minor the injury appears. The foreman or superintendent will then be expected to thoroughly investigate and report the accident to the company office.
 - 4) The company office is responsible for completing the first report of injury form for reporting to the insurance company and state industrial accident commission.
 - 5) The office is also responsible for completion and maintenance of the OSHA 300 forms used to record occupational injuries and illnesses and for posting the log during the month of February.
 - 6) The office will maintain communications with the injured employee, treating physician, and insurance company to ensure that a proper course of treatment is being followed and that the employee is returned to work as quickly as possible.

Electric Power Tools:

- 1) All guards and safety features furnished with hand and power tools shall remain in place and shall not be removed when in use.
- 2) Electric power tools shall be of a double-insulated type or provided with proper grounding. The grounding prong on plugs of power tools shall not be removed.
- 3) Power tool electric cords and electrical extension cords shall not be used to hoist or lower tools, equipment or supplies.
- 4) Employees shall use the appropriate PPE's whenever using electric power tools.

Pneumatic Power Tools:

- 1) Tool retainers shall be used on all pneumatic equipment to prevent ejection of the tool being used in the pneumatic equipment.
- 2) Pneumatic power tools shall be secured to the hose at all times by connecting with a wire, chain or other positive means to prevent the tool from becoming accidentally disengaged from the hose.
- 3) Safety guards shall be used on all portable grinders. The guard shall be installed so that at least one half of the grinding wheel or abrasive disk is covered.
- 4) The safe operating pressure for hoses and tools shall not be exceeded.
- 5) Compressed air hoses shall not be used for hoisting tools, equipment or supplies.
- 6) Employees shall use the appropriate PPE's whenever using pneumatic power tools.

Hand Tools:

- 1) Hand tools such as hammers, sledge hammers, axes, picks, shovels, etc. shall be inspected for evidence of damage such as splintered or damaged handles, cracking/splitting/spalling of the tool head or other signs of breakage.
- 2) All hand tools shall be maintained in a safe condition. Damaged tools shall be removed from service immediately and the foreman or superintendent shall either

 Partnerships Built on Trust SAFETY & HEALTH MANUAL	2. Rules & Disciplinary	Page 4
	Revision Date: 1/8/2024	Updated

have the tool repaired or disposed of. Employees must NEVER use a defective hand tool.

- 3) Employees shall use the appropriate PPE's whenever using hand tools.

Ladder Safety Rules:

- 1) Ladders shall be inspected prior to each use for chips, cracks and other defects.
- 2) Ladder rungs shall be kept clean and free of mud, grease or oil to prevent slips.
- 3) Where possible, ladders shall always be secured or lashed at the top of the ladder to prevent their tipping.
- 4) Ladders shall be erected so that the ladder side rails extend at least 36 inches above the landing or roof surface.
- 5) Cross bracing on the rear section of stepladders shall not be used for climbing unless the ladders are provided with steps for climbing on both sections.
- 6) Employees shall always face the ladder when climbing up or down.
- 7) Ladders shall **NEVER** be placed at an angle greater than 75 degrees to the horizontal.
- 8) The areas at the top and bottom of each ladder shall be kept clear of rubbish, debris, and equipment.
- 9) Stepladders shall only be used on flat, level surfaces.
- 10) All ladders shall be equipped with safety shoes, spikes, or secured in some manner to prevent them from slipping when in use.
- 11) Wood ladders shall NEVER be painted entirely. Paint is only allowed on wooden ladders as a means of identification and marking.
- 12) All ladders shall be inspected for defects such as broken or bent rungs, steps, rails, cross bracing, ropes, pulleys, feet, or any other structural part of the ladder.
- 13) A ladder found to be defective shall be removed from use **immediately** and the foreman or superintendent shall be notified of the problem. The foreman or superintendent shall arrange to have the ladder repaired by a qualified person or shall dispose of the ladder if it cannot be properly repaired.
- 14) Ladders shall NEVER be used as a platform, runway, or scaffold. Ladders shall also NEVER be used as a means of constructing scaffolding by placing planks in between step or extension ladders, except for their use in ladder jack scaffolding systems.
- 15) Step ladders near guardrails shall be no closer than the ladder's height away (i.e. a 12-foot step ladder shall be 12 feet away).

Hazardous Chemicals:

- 1) Employees who handle hazardous materials must receive Hazard Communication training prior to their initial work assignment and annually thereafter.
- 2) A copy of the Beeler Construction Written Hazard Communication Program and Safety Data Sheets (SDS) are available and maintained on site by Beeler Construction foremen or superintendents.
- 3) All containers of hazardous chemicals must be properly labeled. The label must provide the identity, or name of the hazardous chemical, the appropriate hazard

 SAFETY & HEALTH MANUAL	Partnerships Built on Trust	2. Rules & Disciplinary	Page 5
		Revision Date: 1/8/2024	Updated

warnings, and the name and address of the chemical manufacturer. Contact the foreman or superintendent if any container of hazardous chemicals is found with no label.

- 4) All hazardous chemicals must be furnished by the supplier with a Safety Data Sheet (SDS). SDS's contain information on the chemical make-up of materials, flammability, health risks, medical treatments, etc. SDS's for all hazardous chemicals used at Beeler Construction jobsites are available and kept by each foreman or superintendent. Any questions concerning hazardous chemicals used by other contractors at a jobsite should be directed to your foreman or superintendent who will obtain an SDS from the other contractor(s) or general contractor responsible for the jobsite. All Beeler Construction employees may request a copy of the SDS from their foreman or superintendent if they so desire. Any employee who purchases a chemical should check the SDS binder to see if there is an SDS on file, if not they should contact the office so one can be obtained and implemented into the jobsite files.
- 5) Each employee shall receive information and training concerning the hazardous chemicals they work with. This training will cover the following subjects.
 - a. The requirements of the federal Hazard Communication Standard.
 - b. The location of the written Beeler Construction Hazard Communication Program.
 - c. The location in work areas where hazardous chemicals may be present.
 - d. Training in methods used to detect the presence or release of a hazardous chemical.
 - e. Explanation of the potential physical & health hazards of chemicals used.
 - f. Measures that employees can take to protect themselves from the hazards of chemicals in the work area.
 - g. Specific actions that employees are to take in the event of an emergency leak or spill.
 - h. Hazardous chemical labeling, sections of the SDS, explanation of terms used on an SDS, where to find the SDS, and how to request a copy of an SDS.

Flammable Materials:

- 1) NEVER refuel a piece of equipment or vehicle while the engine is running. Extra caution must be exercised when refueling portable equipment with a hot manifold such as pumps, generators, saws, etc.
- 2) Do not store flammable liquids within 10 feet of a portable generator, pump, or electrical equipment.
- 3) Portable containers used to store gasoline or other flammable liquids must be equipped with a self-closing lid, flash screen, and labeled with the contents of the container.
- 4) Oxygen and fuel gas cylinders must be stored in approved areas and separated by at least 20 feet or a firewall with a ½ hour rating.
- 5) All compressed gas cylinders must be used, stored, and secured with rope or chains in an upright position or kept in proper welding carts.

 Partnerships Built on Trust	2. Rules & Disciplinary	Page 6
	Revision Date: 1/8/2024	Updated

SAFETY & HEALTH MANUAL

- 6) When not in use, all cylinders must be closed at the cylinder valve, and any gas remaining in hoses bled off through the torch valve.
- 7) Caps must be placed on all compressed gas cylinders not in use.
- 8) Compressed gas cylinders must NEVER be used inside confined spaces such as drums, pits, excavations, etc.

Proper Lifting Procedures:

- 1) Position your feet as close to the load or object to be lifted.
- 2) Bend at the knees and keep your back as straight as possible.
- 3) Get a firm grip on the load or object to be lifted.
- 4) Hold the load or object close to your body; lift by using leg muscles.
- 5) Lift the load or object slowly holding it as close to your body as possible.
- 6) NEVER twist at the waist or jerk the load while carrying it.
- 7) If it is necessary to turn, shuffle your feet and avoid twisting the back.
- 8) Set the load or object down in the same manner as the lift.
- 9) If the load or object is too heavy to lift or too bulky to carry, get help.

Protection of Tools & Equipment:

- 1) All tools and equipment left at a jobsite at the conclusion of each work day shall be locked, secured, or otherwise protected from possible theft and vandalism.
- 2) Heavy equipment and vehicles left at the jobsite shall be secured by removal of all keys, locking of fuel caps where possible, securing of steel plates, use of hidden kill switches or other anti-theft devices, and placement of equipment making it difficult to move.
- 3) Portable tools and equipment shall be placed and locked in gang boxes at the end of each work day. Each foreman or superintendent shall be responsible for maintaining an inventory of tools and equipment at the jobsite and shall also be responsible for reporting the theft, disappearance, or damage to tools and equipment not occurring during normal work shifts.
- 4) All employees shall also be responsible for reporting evidence of tampering or attempted theft of heavy equipment and machinery used at the jobsite.

Drivers Safety Rules:

- 1) NEVER carry passengers unless authorized by management.
- 2) All drivers and authorized passengers must wear lap and shoulder belts while the vehicle is in operation.
- 3) Drivers must obey posted speed limits at client facilities, if applicable, and on the road. Drivers must know and obey all traffic rules and regulations.
- 4) No driver shall operate a vehicle while under the influence of alcohol or drugs.
- 5) Intentional damage, misuse, abuse, or improper handling of any vehicle driven during the conduct of company business will not be tolerated.
- 6) NEVER operate or use any vehicle that has a "DO NOT OPERATE TAG" on it.
- 7) Horseplay or the reckless operation of a motor vehicle is a serious safety violation.

 Partnerships Built on Trust	2. Rules & Disciplinary	Page 7
	Revision Date: 1/8/2024	Updated

SAFETY & HEALTH MANUAL

- 8) NEVER smoke while fueling vehicles or equipment and do not throw cigarette butts from a vehicle. Smoking on the premises is allowed only in designated areas.
- 9) Drivers must inspect and ensure that all company vehicles contain the required safety equipment, such as fire extinguishers and first aid kit.
- 10) Drivers must only operate a vehicle for which they have received appropriate state licensing.
- 11) Any driver that develops serious medical symptoms which may affect their ability to safely drive must pull the vehicle safely off the road and stop. The driver should request medical assistance.
- 12) All vehicles shall be kept clean of trash and debris. Large items, such as tool boxes, fire extinguishers, lunch boxes, thermos, etc. should be secured to prevent them from becoming missiles during an accident situation.
- 13) Vehicles which haul equipment or material shall be carefully inspected and secured to prevent load shifting or vehicle overloading.
- 14) Drivers must conduct pre-trip inspections of the following items: brakes, steering, head lights, brake lights, turn signals, emergency signals, fire extinguishers, tires, rear view mirrors, windshield wipers, seat belts, heater/defroster, red flags, tarpaulin, backup alarm, low air alarm, hook up, etc.
- 15) Additional driving safety information is outline in the Beeler Construction Fleet Safety program in Section #7 of this manual.

Waste Management Program/Job Cleanliness:

- 1) Training of this program is conducted at time of hire and refresher/ update training is conducted as needed and at a minimum annual basis.
- 2) The waste management area will be designated areas on construction site for waste disposal dumpsters; locations are typically designated by the customer. Prior to dropping any dumpsters on site, the Beeler Construction superintendent shall obtain the customer's/owner's approval. Location, switch out times and debris removal routes all be agreed upon.
- 3) Jobsites must be cleaned up on a daily basis; this shall be the responsibility of all employees on site including subcontractor employees. Debris shall not be allowed to over accumulate; if needed, clean up shall be done periodically during the day/shift so as not to affect work procedures and safety.
- 4) Prior to removing materials from the work area to the dumpster, Beeler Construction's superintendent shall review the best route thru the jobsite; this should involve input from the customer whenever necessary. This is of particular importance when working on jobsites with ongoing operations such as retail, hospitals/health care facilities, offices, educational, etc., when public safety is a concern. Furthermore, this rout should also be reviewed for employee safety by avoiding construction and public vehicular traffic.
- 5) Prior to beginning work, the Beeler Construction superintendent shall review project scopes with all subcontractors to determine an estimated total number of dumpsters required and approximate switch-out dates and times.

 Partnerships Built on Trust SAFETY & HEALTH MANUAL	2. Rules & Disciplinary	Page 8
	Revision Date: 1/8/2024	Updated

- 6) Prior to beginning work, the Beeler Construction superintendent and project manager should review the project for possible salvaged material reuse or material recycling. Some materials suitable for reuse could be: dimensional wood, wood trims and millwork, plywood, counters, cabinetry, metal studs, insulation, structural steel, etc. Other materials may be suitable for recycling such as: metals, glass, plastics, cardboard, carpet, concrete, etc. In an effort to minimize impact on the environment, Beeler Construction promotes the practice of material recycling. Recycling containers shall be provided when deemed beneficial or when requested by the customer; containers should be clearly labeled for respective materials.
- 7) Only approved materials can be disposed of in dumpsters. As a rule of thumb, the following items are banned from landfills: plastic bottles and jars, aluminum containers, bi-metal containers, glass containers, steel (tin) cans, corrugated cardboard, magazines/catalogs, newspapers, office paper, grass clippings and yard debris, vehicle batteries/tires/waste oil/oil filters, household appliances such as washers, dryers, freezers, refrigerators, stoves, etc., and electronics such as televisions and microwaves. Always check the State regulations where the project is located; the disposal vendor should also provide lists of acceptable and unacceptable materials.
- 8) Never overfill or over-stack a dumpster; the typical fill line is the top of the container sides. Always pay attention to never overweight a dumpster, in particular when disposing soils, concrete or other heavy materials.
- 9) Never dispose of any chemicals, fuels, caustic liquids, etc., or other hazardous materials in dumpsters. These should be stored safely on site and only disposed of by a qualified hazardous waste vendor.

Disciplinary Action for Safety Violations

Beeler Construction reserves the right to take any action it deems appropriate, including termination of employment, for safety violations whether they occur the first, second or third time. The following policy is to be implemented whether it is Beeler Construction employee violations or Subcontractor employee violations.

For Beeler Construction Employee Violations:

- 1st Offense: Verbal Warning
- 2nd Offense: Written Warning, superintendent to forward a copy to the office and keep a copy on file on site.
- 3rd Offense: Possible Employee Termination

Beeler Construction's on site supervisor and safety director will be responsible for the policing and enforcement of all safety rules and regulations. A violation is considered as breaking and/or not following any of the rules, procedures or regulations set forth in this Safety Manual. The first violation will result in a verbal warning. After that, all violations are to be written up and kept on file on site. Safety Violation forms are included in each superintendent's safety kits. A copy of this form is also located in the Forms Section of

 SAFETY & HEALTH MANUAL	Partnerships Built on Trust	2. Rules & Disciplinary	Page 9
		Revision Date: 1/8/2024	Updated

this manual. Periodic site safety inspections will be performed by the Beeler Construction safety director. Employee violations will be emphasized during these inspections.

For Subcontractor Employee Violations:

- 1st Offense: Verbal Warning
- 2nd Offense: Written Warning, superintendent to forward a copy to the office and keep a copy on file on site, Beeler Construction project manager will forward a copy to the Subcontractor's office and the Subcontractor's insurance carrier.
- 3rd Offense: Written Warning, superintendent to forward a copy to the office and keep a copy on file on site, Beeler Construction project manager will forward a copy to the Subcontractor's office and the Subcontractor's insurance carrier. The Subcontractor's employee may be terminated from the site.
- 4th Offense: Subcontractor's employee will be terminated from the site

Beeler Construction's on site supervisor and safety director will be responsible for the policing and enforcement of all safety rules and regulations. A violation is considered as breaking and/or not following any of the rules, procedures or regulations set forth in this Safety Manual. The first violation will result in a verbal warning. After that, all violations are to be written up and kept on file on site. Safety Violation forms are included in each superintendent's safety kits. A copy of this form is also located in the Forms Section of this manual. Periodic site safety inspections will be performed by the Beeler Construction safety director. Employee violations will be emphasized during these inspections.

 Partnerships Built on Trust	2. Rules & Disciplinary	Page 10
	Revision Date: 1/8/2024	Updated

SAFETY & HEALTH MANUAL

Drug & Alcohol Policy

PURPOSE: As a part of its comprehensive health and safety program, Beeler Construction provides a workplace that is free from the hazards and effects of alcohol and other mood altering chemicals. This procedure clarifies the policy of the company with regard to the use of alcohol and other mood altering chemicals.

POLICY: Beeler Construction strictly enforces its drug and alcohol policy that follows. Employees found to be in violation of its drug and alcohol policy will be subject to the provisions that follow, including disciplinary action. The health and safety of other employees, subcontractors, and the general public, will not be jeopardized by an employee found to be in violation of this policy.

▼ General Provisions:

Conscientious efforts to seek and use help will not jeopardize an employee’s job or career. Use of a program, however, is not a substitute for a foreman or superintendent’s action or the application of normal discipline. The intent of this policy is to provide a drug-free, healthy, safe and secure work environment.

- 1) A condition of employment at Beeler Construction is that employees report to their jobs in the appropriate mental and physical condition ready to work. A foreman or superintendent or management shall determine fitness for duty.
- 2) Beeler Construction prohibits employees from using or consuming any amount of mood-altering, non-prescription substances on Beeler Construction premises, in Beeler Construction vehicles, or during working hours, including breaks, meals and overtime. Further, any illegal possession, transfer or sale of such substances is also prohibited. This includes all forms of alcohol, narcotics, depressants, amphetamines, hallucinogens, and marijuana. Violation will result in immediate removal from the work site and appropriate disciplinary action, which can include termination of employment.
- 3) Since physician-prescribed use of mood-altering drugs, narcotics, depressants, amphetamines or other controlled substances can adversely affect work behavior, job performance, and the ability to safely drive a motor vehicle, it is in the best general interest of all the employees that the foreman or superintendent and management should know of such use. Therefore, in the interest of health and safety and to avoid a misunderstanding, employees should report the use of such prescriptions to their immediate foreman or superintendent, or if not available, to management. Disclosure of the use of prescriptions shall be considered confidential.
- 4) When there is a reason to believe an employee is violating this policy, he/she can be required to report to a designated physician or clinic on Beeler Construction time and at Beeler Construction’s expense for a fitness-for-duty examination which

 Partnerships Built on Trust	2. Rules & Disciplinary	Page 11
	Revision Date: 1/8/2024	Updated

SAFETY & HEALTH MANUAL

- may include testing. Employees who refuse to submit to an examination will be removed from the work site and subject to appropriate disciplinary action.
- 5) Whenever appropriate, illegal substances found on Beeler Construction property or jobsites will be turned over to a local law enforcement agency for further investigation, which may result in criminal prosecution.
 - 6) If an employee with an alcohol or drug problem refuses assistance or fails to keep his/her commitment to treatment while showing no improvement in job performance, disciplinary action may be deemed appropriate.
 - 7) An employee who is arrested for illegal off-the-job drug activity may be considered in violation of this policy. An employee can be suspended with or without pay, pending resolution of criminal charges. In deciding what action to pursue, management shall consider:
 - ✓ The nature of involvement.
 - ✓ The employee's present job assignment.
 - ✓ The employee's record with Beeler Construction.
 - ✓ Other factors relative to the impact of the employee's involvement upon the conduct of Beeler Construction business and the maintenance of the public trust.

OSHA Inspection Procedures

Purpose

It is Beeler Construction policy to fully cooperate with inspections by regulatory agencies such as the Occupational Safety and Health Administration (OSHA).

Scope

This section applies to all Beeler Construction projects.

Policies

The following procedures **must** be followed when an OSHA or another regulatory agency representative arrives at a Beeler Construction project.

Notification

Notify the Safety Department as soon as the compliance officer arrives at the project site. The Safety Representative will immediately head to the project. Notify Beeler Construction management that OSHA is onsite.

Correct Any Unsafe Conditions

Look around before OSHA is walking the worksite. Fix any unsafe condition that was created by Beeler Construction. If Beeler Construction employees are exposed to other contractor's hazard, remove workers from the hazardous area. While OSHA is onsite do not perform any high hazard work, such as working off ladders, scaffolding or where fall protection is needed.

 <p>Partnerships Built on Trust</p> <p>SAFETY & HEALTH MANUAL</p>	<p>2. Rules & Disciplinary</p>	<p>Page 12</p>
	<p>Revision Date: 1/8/2024</p>	<p>Updated</p>

Inspection Procedures

OSHA Inspections

It is Beeler Construction policy to fully cooperate with inspections by regulatory agencies such as the Occupational Safety and Health Administration (OSHA).

The following procedures must be followed when an OSHA or another agency representative arrives at our project:

Inspectors must be escorted

Instruct all BEELER CONSTRUCTION personnel to escort the inspector to the Manager. This should be done without entering the job site if at all possible. Ask to see their identification “badge” and a business card. If there are any questions about their identification contact the OSHA’s Area Office for further identification.

Forms must be completed

Fill out Beeler Construction forms completely and give a copy to the Safety Department.

Inspectors must be accompanied

Manager will accompany the inspector at all times.

Be courteous

Extend every courtesy to make the inspector’s brief visit as pleasant as possible.

Correct any unsafe conditions immediately

Before the inspector leaves the site, request clarification of any hazards observed and the abatement that the inspector would like to see.

The inspector may talk to employees

If the inspector wishes to talk to employees during the walk around, he is allowed to do so by law. This talk should be limited to about five (5) minutes.

The employee has the right to refuse to talk to the inspector. Cooperation is expected from all staff on the site.

All employees, Beeler Construction and subcontractors, should cooperate with the inspection.

Explain that Beeler Construction, subcontractors and OSHA are conducting this inspection together, and the welfare of ALL employees is the purpose for the inspection.

Inspections may be videotaped

 Partnerships Built on Trust	2. Rules & Disciplinary	Page 13
	Revision Date: 1/8/2024	Updated
SAFETY & HEALTH MANUAL		

Some inspectors may use a video camera. Be careful what is said when the recorder is being used.

 SAFETY & HEALTH MANUAL	Partnerships Built on Trust	2. Rules & Disciplinary	Page 14
		Revision Date: 1/8/2024	Updated

Pictures may be taken

If the inspector takes a picture, Beeler Construction should take two or three to get a complete view of the hazard.

Identify the company responsible for violations

If violations are alleged by the OSHA representative, identify the company responsible for or contributing to the conditions leading to the violation during the closing conference.

Post citations conspicuously

Citations must be posted for three days or until the citation is abated, whichever comes first, on the job site in a place where employees pass frequently.

Inspection follow-up

1. Review all proposed penalties and citations.
2. Set-up and attend the informal conference with OSHA.

OSHA INSPECTION REPORT

Inspection Date/Time: _____

Pre-Inspection	YES	NO
Person and title contact by OSHA:		
Did inspector show his credentials? If no, why?	<input type="checkbox"/>	<input type="checkbox"/>
Names of OSHA inspectors and their office area:		
Reason for the inspection:		
Employee complaint? (If yes, attach copy. OSHA is required by law to provide a copy).	<input type="checkbox"/>	<input type="checkbox"/>
Scheduled inspection?	<input type="checkbox"/>	<input type="checkbox"/>
Other (comment)	<input type="checkbox"/>	<input type="checkbox"/>
Opening Conference		
Names of contractors, their representatives and titles (or attach list):		
Inspection Tour	YES	NO
Who from Beeler Construction accompanied the OSHA inspector?		
Who else joined the OSHA inspection group?		
Did the inspector take any photographs?	<input type="checkbox"/>	<input type="checkbox"/>
Did Beeler Construction take any photographs?	<input type="checkbox"/>	<input type="checkbox"/>
Were safety hazards and unsafe acts observed? If yes, what were they and who had responsibility?	<input type="checkbox"/>	<input type="checkbox"/>
Was immediate corrective action taken? If no, why?	<input type="checkbox"/>	<input type="checkbox"/>
Special comments regarding inspection:		
Closing Conference	YES	NO
Did OSHA hold closing conference with Beeler Construction?	<input type="checkbox"/>	<input type="checkbox"/>
With other contractors?	<input type="checkbox"/>	<input type="checkbox"/>
Names of contractors, their representatives and titles (or attach list):		
What alleged OSHA violations were discussed and with whom (or attach list):		
<p>At the closing conference, it is very important to establish which citations rightfully belong to Beeler Construction versus other companies. When citations are incorrectly assigned, Beeler Construction is forced to spend unnecessary time and money contesting them.</p> <p>This OSHA Inspection Report is to be started at the beginning of and completed immediately after an OSHA inspection.</p>		



Partnerships
Built on Trust

SAFETY & HEALTH MANUAL

2. Rules & Disciplinary

Page
16

Revision Date: 1/8/2024

Updated

 Partnerships Built on Trust	3. Emergency Action Plan	Page 1
	SAFETY & HEALTH MANUAL	Revision Date: 1/8/2024

Emergency Procedures

PURPOSE: The purpose of this policy is to provide Beeler Construction employees and management with the information necessary to safely and properly respond in the event of an emergency that affect the health and safety of employees.

POLICY: Beeler Construction provides a safe and healthful workplace for all of its employees. All employees must become familiar with the following Emergency Action Plan requirements and their responsibilities in the event an emergency occurs.

TRAINING: All Beeler Construction employees shall receive initial Emergency Action plan training and annual refresher training thereafter. This training shall be documented with the employee name, date and trainer recorded.

▼ Responsibilities:

Management:

Beeler Construction management has overall responsibility for the safety of company employees, facilities and operations in the event of an emergency. Management is responsible for ensuring that the instructions in this plan are implemented in a timely manner once the emergency situation becomes apparent and for handling communications to emergency response agencies and the press.

Employees:

Employees of Beeler Construction are responsible for becoming familiar with this procedure and the evacuation routes posted in each facility. Employees are also responsible for following the instructions of their foreman or superintendent or management during the actual emergency.

Management and Employees:

The primary objective during any emergency is the preservation of life. In the event of any emergency, the first priority is to safely evacuate or protect the lives of all persons affected. No employee or member of management shall put their health or safety at risk by taking any action to protect or secure the facility during the emergency. Additionally, no employee or member of management shall put their health or safety at risk by taking any action to rescue another person that may be in imminent danger as a result of the emergency.

 Partnerships Built on Trust SAFETY & HEALTH MANUAL	3. Emergency Action Plan	Page 2
	Revision Date: 1/8/2024	Updated

▼ **Evacuation Routes:**

If it becomes necessary to safely evacuate a facility because of an emergency, evacuation routes need to be located. All employees shall become familiar with the emergency exits and evacuation routes within the facility as it may become necessary to use alternate means of exit during an emergency.

▼ **Emergency Exits:**

Emergency exits must be kept accessible at all times. Aisles and paths to emergency exits must be kept open and free of debris and materials which might impede or trip persons attempting to exit. Emergency exits must NEVER be locked through the use of chains or hasps which prevent them from opening from the inside. Blocking or intentionally locking emergency exits and paths to emergency exits is a serious safety violation and subject to disciplinary action.

▼ **Communicating the Emergency:**

The first priority in all emergencies is the communication of the type and extent of the emergency to other Beeler Construction and subcontractor employees. The method of properly communicating the emergency is detailed in each specific emergency procedure that follows.

▼ **Fire and Chemical Spill Emergencies:**

Communication:

- 1) The first priority in the event of an emergency is the prompt communication of the emergency to all personnel at the project site and/or related field offices.
- 2) Communication of the existence of an emergency shall be by radio, cell phone or whatever means the employee has to announce the emergency, including existing alarm system or public address system, at jobsites so equipped.
- 3) Upon discovery of a spill, the employee must leave the immediate area and inform other employees of the spill in the area, unless the employee can safely contain or prevent the spread of the spill into other areas or into floor drains.
- 4) A foreman or superintendent, or other employee in absence of a foreman or superintendent, should inform occupants in adjacent buildings or occupancies of the existence, nature, and location of the emergency.
- 5) If safe to do so, jobsite personnel shall call 911 and notify the fire department of the nature and location of the emergency within the building.

 Partnerships Built on Trust SAFETY & HEALTH MANUAL	3. Emergency Action Plan	Page 3
	Revision Date: 1/8/2024	Updated

Evacuation:

- 1) After the emergency has been communicated, all employees must promptly and safely evacuate the facility.
- 2) All employees must NEVER run as they exit the building unless they must do so to escape the fire or spill.
- 3) Employees operating equipment that can be shut down in the immediate area where they are working can do so, **but only if it is safe to do so**, as they prepare to exit.
- 4) Employees evacuating the building may assist other employees if they are injured or disoriented, **but only if it is safe to do so**, as they prepare to exit.

Accounting for Employees:

- 1) Employees exiting the building shall assemble in areas located a safe distance from the building and away from fire department or emergency operations.
- 2) Employees should remain a safe distance away from the building, until informed otherwise by the responding fire department.
- 3) Employees should relocate to another designated assembly area if the area they are in is downwind of smoke, gases or vapors generated by the fire or spill.
- 4) Supervisors are responsible for taking a head count of their employees to determine if all employees have been safely evacuated from the facility, including subcontractor's employees.

Fire Department and Press Communications:

- 1) The most senior management official from Beeler Construction shall meet the first responding unit from the fire department as they arrive to the emergency.
- 2) This person should communicate the nature, location and extent of the emergency within the building.
- 3) Other information, such as the location of the storage of any chemicals or flammable liquids and gases, existence of sprinkler system, etc. shall be communicated to the responding fire department official.
- 4) Only the most senior management official from Beeler Construction shall speak to a reporter from any radio, television or newspaper organization that responds to the emergency scene.
- 5) The management official should refer any specifics regarding the fire to the highest ranking official from the responding fire department.
- 6) NEVER offer speculation regarding any employees unaccounted for, the extent of the damage, or cause of the emergency to the press. Be polite, but offer little in the way of specific information.
- 7) Reassure the press that the situation is in the hands of the responding fire department and that every effort will be made to determine the cause and repair the damage.

 Partnerships Built on Trust	3. Emergency Action Plan	Page 4
	SAFETY & HEALTH MANUAL	Revision Date: 1/8/2024

Insurance Communications:

- 1) As soon as reasonably possible following the emergency, a management official from Beeler Construction should contact the insurance agent or company and inform them of the emergency.
- 2) It is important that salvage efforts be taken underway as soon as possible to minimize damage and to aid in re-establishing operations as soon as possible.

▼ Severe Weather:

Communication:

- 1) The first priority in the event of the onset of severe weather is the prompt communication of the emergency to all affected Beeler Construction and subcontractor's employees.
- 2) Communication of the existence of severe weather shall be by radio, cell phone, intercom, or public address system, in facilities so equipped.
- 3) If severe weather, such as dangerous thunderstorms or tornadoes, is present in the area, a Beeler Construction employee shall monitor local radio, television or internet newscasts to keep updated on the location and movement of the storm.
- 4) If the news media broadcasts, or activation of local emergency horns indicate the approach of a tornado, the foreman or superintendent shall immediately be notified.

Protection of Employees at Jobsites:

- 1) All employees and subcontractor's employees should relocate to an interior portion of the building away from glass windows and doors.
- 2) The foreman or superintendent should instruct employees to close all overhead doors, exit doors, and windows immediately.
- 3) Employees should congregate towards the center of the building away from any windows and doors.
- 4) Subcontractor's employees working on scaffolding, roofs, or any other outdoor or elevated work platform must be instructed to stop work and seek shelter inside or the structure.

Insurance Communications:

- 1) As soon as reasonably possible following the storm and resulting damage, a management official from Beeler Construction should contact the insurance agent or company and inform them of damage caused by the storm or tornado.
- 2) It is important that salvage efforts be taken underway as soon as possible to minimize the extent of the claim and to aid in re-establishing operations as soon as possible.

 Partnerships Built on Trust	3. Emergency Action Plan	Page 5
	Revision Date: 1/8/2024	Updated

SAFETY & HEALTH MANUAL

Medical & First Aid Program

PURPOSE: The purpose of this policy is to provide Beeler Construction employees and management with the information necessary to safely and properly respond to jobsite injuries that require medical and or first aid attention.

POLICY: Beeler Construction provides a safe and healthful workplace for all of its employees. All employees must become familiar with the following Medical and First Air program; and their responsibilities in the event an injury or medical emergency situation occurs.

TRAINING: All Beeler Construction employees shall receive initial Medical and First Aid training, refresher training will be provided periodically. Additionally, certified First Aid/CPR/AED training is available for all interested employees. It is Beeler Construction’s intent to have all superintendents/foreman or crew leaders certified in Basic First Aid/CPR/AED training. Any and all training shall be documented, with the employee name, date and trainer recorded.

PROCEDURES:

▼ Basic Glossary:

Minor First Aid Treatment - treatment of minor injuries such as cuts, scratches, bruises and burns that do not require a doctor’s treatment shall be performed by Beeler Construction’s on-site crew leader for any Beeler Construction and subcontractor employees.

Advanced First Aid Treatment – this involves treatment of injuries beyond minor injuries that would require a doctor’s treatment and possibly on-site treatment by a certified First Aid Responder or professional medical care technician.

CPR – this refers to Cardiopulmonary Resuscitation, this is a lifesaving technique useful on emergencies including heart attack, near drowning, shocking, or any event in which someone’s breathing or heartbeat has stopped or is in distress.

AED – this refers to Automated External Defibrillator and is a piece of medical equipment used on a person who is in sudden cardiac arrest. An AED delivers an electric shock to the person’s heart to restore the heart’s normal rhythm.

First Responder – this is a person who is certified in first aid, CPR and AED use. First Responders provide medical assistance until professional medical care can be

 Partnerships Built on Trust	3. Emergency Action Plan	Page 6
	SAFETY & HEALTH MANUAL	Revision Date: 1/8/2024

provided. First Responders shall be certified by the American Red Cross or an equivalent organization.

 Partnerships Built on Trust	3. Emergency Action Plan	Page 7
	Revision Date: 1/8/2024	Updated

SAFETY & HEALTH MANUAL

▼ General Provisions:

- 1) Emergency contact information shall be conspicuously posted; this shall include telephone numbers of physicians, hospitals, ambulances, police/sheriff and fire department.
- 2) Before work begins on a project, provisions shall be made to ensure prompt medical attention in the event of a medical emergency or serious injury. This shall include a defined plan for transportation of injured employees to the nearest health care facilities.
- 3) Beeler Construction shall ensure the availability of medical personnel for advice and consultation on matters of occupational health.
- 4) In the event work is being performed where medical services are not available, a person with a valid certificate in first aid training shall be available at the jobsite to render first aid.
- 5) First Aid Supplies/Kits shall be provided on all Beeler Construction job-sites. The kits will be sized according to the number of anticipated total Beeler Construction and subcontractor employees. These kits typically will include; a First Aid Guide, adhesive bandages, gauze roll, sterile pads, antibiotic & burn ointments, first aid creams, alcohol swabs, hand sanitizer, over the counter pain medications, cold and hot packs, medical scissors & tweezers, eye/skin wash, and first aid PPE's. First aid kits shall be evaluated on a per job basis, only kits appropriate/specific to the jobsite environment shall be used. First aid kits are to be inspected on a regular basis to assure they are adequately stocked with supplies.
- 6) Eye wash kits shall be provided, kit requirements will be based on possible hazards specific the jobsite. Most jobsites will require the eye wash kits included in the standard Safety Kit. Additional eye wash equipment will be provided based on potential hazards.
- 7) All injuries must be documented in accordance with Section 3-8 of this manual. Beeler Construction's on-site crew leader is responsible for documenting and reporting all injuries. All injuries are to be immediately reported to the office.

 Partnerships Built on Trust	3. Emergency Action Plan	Page 8
	Revision Date: 1/8/2024	Updated

SAFETY & HEALTH MANUAL

Jobsite Fire Protection

PURPOSE: The purpose of this policy is to provide Beeler Construction employees and management with the information necessary to safely and properly respond in the event of a jobsite fire and provide employees with requirements concerning fire protection at Beeler Construction jobsites.

POLICY: Beeler Construction provides a safe and healthful workplace for all of its employees. All employees must become familiar with the following Jobsite Fire Protection requirements and their responsibilities in the event a fire occurs that threatens Beeler Construction and subcontractor employees.

TRAINING: All Beeler Construction employees shall receive initial Jobsite Fire Protection training and annual refresher training thereafter. This training shall be documented with the employee name, date and trainer recorded.

PROCEDURES:

▼ General Information:

Evacuation Routes: All public buildings should have evacuation routes posted. Whenever working in a new building or an area of a building that you are not familiar with, one of the first things to check is the emergency evacuation route. Memorize and become familiar with the route.

There are four elements that must be present for a fire to exist. There must be oxygen to sustain combustion, heat to raise the material to its ignition temperature, fuel to support the combustion and a chemical reaction between the other three elements.





Partnerships
Built on Trust

SAFETY & HEALTH MANUAL

3. Emergency Action Plan

Page
9

Revision Date: 1/8/2024

Updated

▼ Types of Fires:

Not all fires are the same. Different fuels create different fires and different types of fires require different types of fire extinguisher agents. There are five classifications of fires: Class A, Class B, Class C, Class D and Class K.



- 1) **Class A** fires are fires in ordinary combustibles such as wood, paper, cloth, trash, and plastics.



- 2) **Class B** fires are fires in flammable liquids such as gasoline, petroleum oil and paint. Class B Fires also include flammable gases such as propane and butane. Class B fires do not include fires involving cooking oils and grease.



- 3) **Class C** fires are fires involving energized electrical equipment such as motors, transformers, and appliances. Remove power and Class C fire becomes one of the other classes of fire.



- 4) **Class D** fires are fires in combustible metals such as potassium, sodium, aluminum and magnesium.



- 5) **Class K** fires are fires in cooking oils and greases such as animal fats, and vegetable fats.



Partnerships
Built on Trust

SAFETY & HEALTH MANUAL

3. Emergency Action Plan

Page
10

Revision Date: 1/8/2024

Updated

▼ Types of Fire Extinguishers:

Different fuels create different fires and different types of fires require different types of fire extinguisher agents. The following is a list of types of fire extinguishers and what Class of fire they should be used to extinguish.



- 1) **Water and Foam** fire extinguishers extinguish the fire by taking away the **heat** element of the fire triangle. Foam agents also separate the **oxygen** element from the other elements. Water extinguishers are for Class A fires only - they should not be used on Class B or C fires. The discharge stream could spread the flammable liquid in a Class B fire or could create a shock hazard on a class C fire. Foam extinguishers can be used on Class A & B fires only. They are not for use on Class C fires due to the shock hazard.



- 2) **Carbon Dioxide** fire extinguishers extinguish the fire by taking away the **oxygen** element of the fire triangle and also by removing the **heat** with a very cold discharge. Carbon dioxide can be used on Class B & C fires. They are usually ineffective on Class A fires.



- 3) **Dry Chemical** fire extinguishers extinguish the fire primarily by interrupting the **chemical reaction** of the fire triangle. Today's most widely used type of fire extinguisher is the multipurpose dry chemical that is effective on Class A, B and C fires. This agent also works by creating a barrier between the **oxygen** element and the **fuel** element on Class A fires. Ordinary dry chemical is for Class B & C fires only. It is important to use the correct extinguisher for the type of fuel! Using the incorrect agent can allow the fire to reignite after apparently being extinguished successfully.



- 4) **Wet Chemical** is a new agent that extinguishes the fire by removing the **heat** of the fire triangle and prevents reigniting by creating a barrier between the **oxygen** and **fuel** elements. Wet chemical or Class K extinguishers were developed for modern, high efficiency deep fat fryers in commercial cooking operations. Some may also be used on Class A fires in commercial kitchens.



Partnerships
Built on Trust

SAFETY & HEALTH MANUAL

3. Emergency Action Plan

Page
11

Revision Date: 1/8/2024

Updated



- 5) **Halogenated** or **Clean Agent** extinguishers include the halon agents as well as the newer and less ozone depleting halocarbon agents. They extinguish the fire by interrupting the **chemical reaction** of the fire triangle. Clean agent extinguishers are primarily for Class B & C fires. Some larger clean agent extinguishers can be used on Class A, B and C fires.



- 6) **Dry Powder** extinguishers are similar to dry chemical except that they extinguish the fire by separating the **fuel** from the **oxygen** element or by removing the **heat** element of the fire triangle. However, dry powder extinguishers are for Class D or combustible metal fires, only. They are ineffective on all other classes of fires.



- 7) **Water Mist** extinguishers are a recent development that extinguishes the fire by taking away the heat element of the fire triangle. They are an alternative to the clean agent extinguishers where contamination is a concern. Water mist extinguishers are primarily for Class A fires, although they are safe for use on Class C fires as well.



- 8) **Cartridge Operated Dry Chemical** fire extinguishers extinguish the fire primarily by interrupting the chemical reaction of the fire triangle. Like the stored pressure dry chemical extinguishers, the multipurpose dry chemical is effective on Class A, B and C fires. This agent also works by creating a barrier between the oxygen element and the fuel element on Class A fires.

Ordinary dry chemical is for Class B & C fires only. It is important to use the correct extinguisher for the type of fuel! Using the incorrect agent can allow the fire to re-ignite after apparently being extinguished successfully.



Partnerships
Built on Trust

SAFETY & HEALTH MANUAL

3. Emergency Action Plan

Page
12

Revision Date: 1/8/2024

Updated

▼ Rules for Fighting Fires:

- 1) Only fight a fire if:
 - ✓ *The fire is small and contained.* The time to use a fire extinguisher is in the early of incipient, stage of a fire. Once the fire starts to grow or spread, it is best to evacuate the building, closing doors and windows behind you.
 - ✓ *If you are safe from toxic smoke.* If the fire is producing large amounts of thick, black smoke or chemical smoke, it may be best not to try to extinguish the fire. Neither should you attempt to extinguish the fire in a confined space. Outdoors, approach the fire with the wind at your back. Remember that all fires will product carbon monoxide and many fires will produce toxic gasses that can be fatal, even in small amounts.
 - ✓ *If you have a means of escape.* You should always fight a fire with an exit or other means of escape at your back. If the fire is not quickly extinguished, you need to be able to get out quickly and avoid becoming trapped.
 - ✓ *If your instincts tell you it's okay.* If you do not feel comfortable attempting to extinguish the fire, don't try - get out and let the fire department do their job.
- 2) Remember the three A's.
 - ✓ **Activate** the building alarm system or notify the fire department by calling 911. Or, have someone else do this for you.
 - ✓ **Assist** any persons in immediate danger, or those incapable on their own, to exit the building, without risk to yourself.
 - ✓ Only after these two are completed, should you **Attempt** to extinguish the fire.
- 3) Fire Extinguisher Use
 - ✓ It is important to know the locations and the types of extinguishers in your workplace prior to actually using one.
 - ✓ Fire extinguishers can be heavy, so it's a good idea to practice picking up and holding an extinguisher to get an idea of the weight and feel.
 - ✓ Take time to read the operating instructions and warnings found on the fire extinguisher label. Not all fire extinguishers look alike.
 - ✓ Practice releasing the discharge hose or horn and aiming it at the base of an imagined fire. Do not pull the pin or squeeze the lever. This will break the extinguisher seal and cause it to lose pressure.
 - ✓ When it is time to use the extinguisher on a fire, **Just remember to P.A.S.S.! (Pull, Aim, Squeeze, Sweep)**

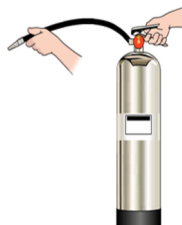

 Partnerships Built on Trust SAFETY & HEALTH MANUAL	3. Emergency Action Plan	Page 13
	Revision Date: 1/8/2024	Updated

Pull the pin
nozzle

Aim the nozzle

Squeeze the handle

Sweep the

 Partnerships Built on Trust SAFETY & HEALTH MANUAL	3. Emergency Action Plan	Page 14
	Revision Date: 1/8/2024	Updated

▼ **Jobsite Fire Protection:**

General Requirements:

- 1) The Beeler Construction superintendent or foreman must ensure that the jobsite is free of an accumulation of unnecessary combustible materials. The superintendent or foreman has the authority to remove or dispose of such materials one hour after the responsible party has been notified.
- 2) Piles of combustible debris should be kept a safe distance from the building and removed as quickly as possible.
- 3) Smoking is typically not allowed on any jobsite. Employees who do smoke must get permission from the building's owners to smoke in a designated area.
- 4) Containers used for the storage and/or dispensing of flammable liquids must be of an approved type, of metal construction and equipped with a self-closing lid and flash screen.
- 5) Storage of flammable liquids inside of buildings at the jobsite must be kept to the minimum amount necessary. Containers used for the storage of gasoline or gasoline mix should be 5 gallons or less.
- 6) Smoking is not allowed in areas where flammable liquids are being used or stored, including all paints.
- 7) Flammable or combustible liquids shall NOT be stored in areas used for exits, stairways or normally used for the safe passage for people.

Fire Protection for Ordinary Combustibles:

- 1) The Beeler Construction superintendent or foreman is responsible for ensuring that adequate portable fire extinguishers are available on site.
- 2) Portable fire extinguishers that are rated at least 2A will be provided for each 3,000 square feet of building area.
- 3) Travel from any point in the building to the nearest portable fire extinguisher should not exceed 100 feet.
- 4) There should be no less than 2 portable fire extinguishers for each floor of a building with at least one extinguisher located next to a stairway.

Fire Protection for Flammable Liquids

- 1) At least one portable fire extinguisher rated 10B must be located within 50 feet or areas where more than 5 gallons of flammable liquids or gases are stored or used at the jobsite.

 Partnerships Built on Trust	3. Emergency Action Plan	Page 15
	SAFETY & HEALTH MANUAL	Revision Date: 1/8/2024

▼ **Fire Extinguisher Inspection:**

Like any mechanical device, fire extinguishers must be maintained on a regular basis to insure their proper operation. You, the owner or occupant of the property where fire extinguishers are located, are responsible for arranging your fire extinguishers' maintenance. Fire extinguishers must be inspected or given a "quick check" every 30 days. For most extinguishers, this is a job that you can easily do by locating the extinguishers in your workplace. Check to see if the fire extinguisher is in the correct location. Make sure it is visible and accessible and not hidden behind tools, materials or equipment. Confirm that the gauge or pressure indicator shows the correct pressure. Avoid locating fire extinguisher too close to hazards being protected so access to the extinguisher will not be affected in the event of a fire.

▼ **Fire Extinguisher Maintenance:**

In addition, fire extinguishers must be maintained annually in accordance with local, state and national codes and regulations. This is a thorough examination of the fire extinguisher's mechanical parts; fire extinguishing agent and the expellant gas. Your fire equipment professional is the ideal person to perform the annual maintenance because they have the appropriate servicing manuals, tools, recharge materials, parts, lubricants, and the necessary training and experience.

 Partnerships Built on Trust SAFETY & HEALTH MANUAL	3. Emergency Action Plan	Page 16
	Revision Date: 1/8/2024	Updated

Reporting Work Related Injuries & Return to Work Program

PURPOSE: To provide requirements and guidelines for the reporting, investigation, and recording of all occupational injuries and illnesses and to provide Beeler Construction management and supervision with the guidelines necessary to locate treatment for injuries and returning injured employees to full duty, or restricted work activity as soon as possible following an occupational injury.

POLICY: It is the policy of Beeler Construction to require the immediate treatment, investigation, and reporting of all accidents, injuries, and job related illnesses involving Beeler Construction employees while on the job. Failure to comply with this procedure can result in disciplinary action, including termination.

PROCEDURE:

▼ Treatment of Occupational Injuries:

Life Threatening or Serious Injuries:

All life threatening or serious injuries involving a Beeler Construction employee require the immediate notification of the 911 operator or local ambulance service. Those employees or persons in the area that are trained in CPR or first aid may provide assistance in sustaining the injured employee until an ambulance arrives.

Once emergency services have been summoned, a foreman or superintendent must be contacted and notified of the emergency. Beeler Construction management will arrange for a foreman, superintendent or manager to go to the hospital where the injured employee has been taken to determine the status of the injured or ill employee.

The designated foreman, superintendent or manager will determine if the injured employee's family has been contacted regarding the emergency. They will either contact the injured employee's family, or arrange for hospital staff to make the contact and will remain at the hospital to meet the injured employee's family. The Beeler Construction representative must reassure the family that the company will handle all matters related to the emergency, including medical bills, pay for time off, etc., if the emergency is CLEARLY work related.

Non-Life Threatening or Non-Serious Injuries:

In the event a Beeler Construction employee receives an injury that requires medical treatment or evaluation, that employee shall be taken to the nearest designated medical clinic or hospital. The employee must NEVER be allowed to transport himself, or arrange for transportation to the clinic for initial treatment or evaluation.

 Partnerships Built on Trust	3. Emergency Action Plan	Page 17
	Revision Date: 1/8/2024	Updated

SAFETY & HEALTH MANUAL

The foreman or superintendent of the injured employee must remain at the clinic until the injured employee has been treated and evaluated by the physician or health professional. If necessary, the foreman or superintendent may need to arrange for transportation of the injured employee back to work or to his home.

▼ Notification:

Employee’s Responsibility:

The first priority in the event of an injury is to ensure that the injured employee receives the appropriate first aid or medical treatment. Reporting activities shall only be initiated once appropriate medical treatment has been obtained.

It is the responsibility of all Beeler Construction employees to immediately report to their foreman or superintendent the occurrence of an injury while at work. Each injured Beeler Construction employee will be expected to complete the Employee Accident Report form in this procedure.

Management & Office Responsibility:

Upon notification of an accident resulting in injury to a Beeler Construction employee, the foreman or superintendent shall contact the office immediately. The foreman or superintendent shall complete the form at the end of this procedure based on information provided by the injured employee or witnesses.

It is the responsibility of the injured employee’s foreman or superintendent to completely and thoroughly investigate the occurrence of all injuries and accidents that occur in their area. The foreman or superintendent may seek the guidance of their manager in the event of a serious or complicated situation or if there is reason to believe that fraud is involved.

The primary objective of all accident investigation and reporting is the identification of the factors that caused the accident to occur. Such factors may include a lack of training of the injured employee, improperly maintained equipment, violation of a safety rule or safety procedure, or commission of an unsafe act by the injured person or other employee. Once all causes have been identified and examined, the foreman or superintendent must identify and implement corrective measures designed to prevent the recurrence of a similar accident in the future. The reporting and investigation process shall not be considered complete until corrective action has been completed.

Upon receipt of the foreman or superintendent’s report of injury form, the office will prepare the first report of injury form and forward to the appropriate state agency for all injuries that require reporting. Notification will be provided immediately to the claims department of the insurance carrier via fax, phone or both.

The office shall be responsible for auditing the timeliness and completeness of accident reporting. If an audit determines that a Beeler Construction employee has failed to

 Partnerships Built on Trust	3. Emergency Action Plan	Page 18
	SAFETY & HEALTH MANUAL	Revision Date: 1/8/2024

report an on the job injury, that employee is subject to disciplinary action, including possible termination.

 Partnerships Built on Trust	3. Emergency Action Plan	Page 19
	SAFETY & HEALTH MANUAL	Revision Date: 1/8/2024

Restricted Work Activity:

The foreman, superintendent or management must communicate to the treating physician that restricted work activity (light duty) is available for the injured employee. The foreman or superintendent shall request in writing the specific physical restrictions or limitations placed on the employee by the physician. Unless the restrictions call for bed rest or a total restriction of activity, the foreman or superintendent shall request that the employee be returned to work on a restricted basis. If the physician has any specific questions concerning the restricted work activity program, request that the doctor contact the Beeler Construction office for additional information. The form attached may be sent by the office to the employee's selected physician immediately after notice that an employee is seeking treatment from a physician of their choice.

If the employee is returned to work on a restricted basis, Beeler Construction will attempt to find a job or task that is within the physical limitations imposed by the physician.

All absences from work for an injured employee that has been released to work with restrictions shall be treated as personal absences and not as days away from work as a result of the occupational injury when light duty has been offered to the injured employee.

▼ Rehabilitation:

Beeler Construction will support all efforts necessary to facilitate the rehabilitation of the injured employee. The emphasis of the rehabilitative program will be to return the injured employee to work at the same capacity as before the injury occurred. The injured employee is expected to arrange treatment dates and times around their work schedule, wherever possible.

▼ Suspicious Claims:

There may be situations where a claim appears to be suspicious in nature. Possible indications include:

- ✓ Late reporting of the claim
- ✓ Unwitnessed fall or strain
- ✓ Injuries reported at start of shift
- ✓ Vague descriptions of what caused the injury
- ✓ Physician finds no evidence of injury

If a claim appears to be suspicious in nature, contact the insurance company claims adjuster immediately and notify them of the suspicious nature of the claim. The insurance company may determine that surveillance is necessary and early intervention is critical.

 Partnerships Built on Trust	3. Emergency Action Plan	Page 20
	SAFETY & HEALTH MANUAL	Revision Date: 1/8/2024

Beeler Construction will not tolerate fraudulent worker's compensation claims and will take appropriate action if fraudulent claims are discovered.

 Partnerships Built on Trust	3. Emergency Action Plan	Page 21
	Revision Date: 1/8/2024	Updated

SAFETY & HEALTH MANUAL

OSHA 300 Log and Summary of Occupational Injuries and Illnesses:

The office shall also be responsible for maintaining the OSHA 300 Log and Summary of Occupational Injuries and Illnesses. Entries shall be made for all injuries and illnesses that require more than first aid treatment. The back of the log describes what injuries should be entered on the log. The log shall be kept current as injuries occur during the calendar year.

The log shall be posted where all employees can read it no later than February 1 the following year and shall remain in place until at least March 1. The OSHA 300 log shall be kept on file in the office for at least 5 years following its completion. A copy of the OSHA 300 log is found at the end of this procedure.

Reporting Motor Vehicle Accidents

PURPOSE: To provide requirements for the reporting, investigation and recording of all motor vehicle accidents involving Beeler Construction vehicles or motor vehicle accidents involving personal vehicles that occur during the conduct of business for Beeler Construction.

POLICY: It is the policy of Beeler Construction to require the immediate and accurate reporting of ALL motor vehicle accidents involving Beeler Construction vehicles or accidents that occur during the conduct of business for Beeler Construction. Failure to comply with this procedure can result in disciplinary action, including termination.

PROCEDURE:

▼ Notification of Motor Vehicle Accidents:

Driver's Responsibility:

The first priority in the event a motor vehicle accident occurs involving a Beeler Construction employee is to seek immediate medical attention for all injured persons. Reporting activities shall only be initiated once appropriate medical treatment has been obtained. In all cases where an accident occurs involving a Beeler Construction employee and another vehicle, immediate notification of the local police or law enforcement agency is required.

It shall be the responsibility of all Beeler Construction employees to contact the office immediately. Each Beeler Construction vehicle shall contain an accident reporting form supplied by the insurance carrier. The driver must complete all applicable questions on the form in the event an accident occurs. The completed forms in the packet, and a copy of the completed police report, if available, should be taken immediately to the office.

 Partnerships Built on Trust	3. Emergency Action Plan	Page 22
	SAFETY & HEALTH MANUAL	Revision Date: 1/8/2024

Supervisor's Responsibility:

Upon notification of an accident resulting in injury to either a Beeler Construction employee or other party involved in the accident, the employee shall notify the office immediately by phone. The employee must forward all forms to the office, including a copy of the completed police report, if available, within 24 hours. In the event an accident occurs involving injuries or major property damage, a copy of the completed forms and police report shall be provided to the office immediately.

Office Responsibility:

If available, a copy of the report completed by the police department should be forwarded to the insurance company, along with the completed accident report form and other information collected at the time of the accident. Based on information provided in both the driver's completed forms and police reports, the office shall determine whether the accident was chargeable. A chargeable accident is one in which the Beeler Construction driver failed to exercise every reasonable precaution to prevent the accident from occurring. An accident may be considered chargeable even if the police do not issue a citation or assess fault for the accident. The occurrence of multiple preventable accidents may invoke the disciplinary process, including possible termination.

▼ Auditing Accident Reporting:

Beeler Construction office shall be responsible for auditing the timeliness of accident reporting. Periodic loss runs provided by the insurance carrier will provide the information necessary to determine whether accidents have been reported as required by this procedure.

If an audit determines that a Beeler Construction employees has failed to report a motor vehicle accident, that employee is subject to disciplinary action, including termination.

Additional vehicular accident reporting information can be found in Section #7 Fleet Safety Program.

 Partnerships Built on Trust SAFETY & HEALTH MANUAL	4A. Hearing Conservation and Protection	Page 1
	Revision Date: 1/8/2024	Updated

Hearing Conservation & Protection

PURPOSE: The purpose of this section is to identify sound levels at which protective measures must be utilized on Beeler Construction jobsites and to offer information to assist in complying with these requirements. All Beeler Construction employees shall wear protections or implement hearing protection procedure as set forth in this section. All hearing protectors/PPE's shall be provided at no cost to the employees by Beeler Construction.

POLICY: Beeler Construction provides a safe and healthful workplace for all of its employees. This section details the safe use of hearing protectors/PPE's, outlines work situations where hearing protection is required and identifies sound level limits that require hearing protection. The basis of this policy is to comply with OSHA 29 CFR 1910.95 "Occupation Noise Exposure".

TRAINING: All Beeler Construction employees shall receive initial hearing protection training and annual refresher training. Employees shall be trained in when to wear hearing protectors/PPE's, what type of hearing protector should be worn, techniques on how to safely wear and remove hearing protectors, the limitations of hearing protectors and the care and maintenance of hearing protectors.

▼ General Requirements:

- 1) Noise or unwanted sound is one of the most pervasive occupational health problems. It is a by-product of many construction activities. Repeated exposure to high levels of noise may cause hearing loss. The extent of hearing loss depends on the frequency and intensity of the noise and on the duration of exposure. Noise-induced hearing loss can be temporary or permanent.
- 2) The purpose of this section is to identify sound levels at which protective measures must be utilized on Beeler Construction projects and offer information to assist in complying with these requirements.
- 3) Temporary hearing loss (also called temporary threshold shift) results from short-term exposures to noise, with normal hearing returning after a period of rest. Generally, prolonged exposure to high noise levels over a period of time causes permanent hearing loss. A person who regularly sustains noise-induced temporary threshold shifts eventually will suffer a permanent threshold shift.
- 4) Hearing loss is particularly insidious because it may occur very gradually. In fact for a long time, the worker may not notice any change until the hearing loss begins to interfere with everyday communication. Beeler Construction has instituted the requirements of this section of the Safety & Health Manual to protect Beeler employees from potential hearing loss. Employee must wear hearing protection, as required in this policy, to protect against such hearing loss.



Partnerships
Built on Trust

SAFETY & HEALTH MANUAL

4A. Hearing Conservation and Protection

Page
2

Revision Date: 1/8/2024

Updated

Subcontractors of any tier must require its workers to wear hearing protection as required in this policy, to protect against such hearing loss.

- 5) Engineering controls are the most effective defense against the hazards of noise. In many instances, however, the application of engineering controls in construction is not feasible due to the configuration of equipment, tools or the tasks being performed. When noise controls, through engineering controls are not feasible or until controls can be installed, an effective hearing conservation program (HCP) must be emphasized.

▼ Application & Procedures:

- 1) This program applies to all Beeler Construction projects where 8 hour time weighted averages (TWA) exceed 85 dBA. Any employee experiencing noise at or above this action level is required to wear hearing protection.
- 2) It is Beeler's policy that engineering controls, if feasible, be implemented to protect against hearing loss in Beeler employees. When engineering controls are not feasible, the HCP must be utilized and emphasized with Beeler Construction employees and subcontractors.
- 3) When engineering controls are not feasible and employee noise exposure equals or exceeds the action level (as defined below), the affected Beeler Construction project shall administer an effective and continuing HCP. Elements for such programs include noise exposure monitoring when noise levels are not known, use of hearing protection and employee training. The primary objective of the program shall be to:
 - ✓ Evaluate noise levels and exposure in the workplace. This can be accomplished through monitoring of existing data or studies (see related documents section).
 - ✓ Identify job positions/tasks with noise exposures equal to or exceeding the "action level" (85 dBA as an 8-hour TWA) and positions with noise exposures exceeding the permissible exposure limit (90 dBA as an 8-hour TWA).
 - ✓ Ensure the availability and use of hearing protectors in areas/tasks where noise levels exceed 85 dBA and in job positions exposed at or above the action level to reduce noise exposures and protect employee hearing capabilities.
 - ✓ Provide an effective training program for all Beeler Construction employees exposed to noise at or above the action level.
 - ✓ Require Beeler Construction subcontractors, of any tier, to provide for its employees the requirements and protections provided by Beeler Construction to its employees in this section.
 - ✓ When noise levels are below the requirement to have an HCP in place, workers are encouraged to use hearing protection even though it may not be required. Hearing protection in noisy locations although not required may reduce the long term effects of hearing loss.

 Partnerships Built on Trust SAFETY & HEALTH MANUAL	4A. Hearing Conservation and Protection	Page 3
	Revision Date: 1/8/2024	Updated

▼ **Hearing Protection Types:**

The typical types of hearing protectors include ear plugs, semi-insert ear plugs and ear muffs.

Ear plugs are inserted to block the ear canal. They may be pre-molded (pre-formed) or moldable (foam ear plugs). Ear plugs are sold as disposable products or reusable plugs. Custom molded ear plugs are also available.

Semi-insert ear plugs which consist of two ear plugs held over the ends of the ear canal by a rigid headband.

Ear muffs consist of sound-attenuating material and soft ear cushions that fit around the ear and hard outer caps. They are held together by a head band.

The choice of hearing protectors is a very personal one and depends on a number of factors including level of noise, comfort, and the suitability of the hearing protector for both the worker and his environment. Most importantly, the hearing protector should provide the desired noise reduction. It is best, where protectors must be used, to provide a choice of a number of different types to choose from.

If the noise exposure is intermittent, ear muffs are more desirable since it may be inconvenient to remove and reinsert earplugs. There are advantages and disadvantages associated with the use of either ear muffs or ear plugs.

Ear plugs can be mass-produced or individually molded to fit the ear and they can be reusable or disposable. On the positive side, they are simple to use, less expensive than muffs and more comfortable in hot or damp work areas. On the negative side, they provide less protection than some muffs and should not be used in areas having noise levels over 105 dB(A) (A-weighted decibels). They are not as visible as muffs and a supervisor cannot readily check to see if workers are wearing them. They must be properly inserted to provide adequate protection.

Ear muffs can vary with respect to the material and depth of the dome and the force of the headband. The deeper and heavier the dome, the greater the low-frequency attenuation provided by the protector. The headband must fit tightly enough to maintain a proper seal, yet not be too tight for comfort. On the positive side, ear muffs can usually provide greater protection than plugs, although this is not always true. They are easier to fit, generally more durable than plugs and they have replaceable parts. On the negative side, they are more expensive and often less comfortable than plugs, especially in hot work areas. In areas where noise levels are very high, muffs and plugs can be worn together to give better protection.



Partnerships
Built on Trust

SAFETY & HEALTH MANUAL

4A. Hearing Conservation and Protection

Page
4

Revision Date: 1/8/2024

Updated

The following table summarizes the differences between ear plugs and ear muffs.

Comparison of Hearing Protection	
Ear Plugs	Ear Muffs
<p>Advantages:</p> <ul style="list-style-type: none">• small and easily carried• convenient to use with other personal protection equipment (can be worn with ear muffs)• more comfortable for long-term wear in hot, humid work areas• convenient for use in confined work areas	<p>Advantages:</p> <ul style="list-style-type: none">• less attenuation variability among users• designed so that one size fits most head sizes• easily seen at a distance to assist in the monitoring of their use• not easily misplaced or lost• may be worn with minor ear infections
<p>Disadvantages:</p> <ul style="list-style-type: none">• requires more time to fit• more difficult to insert and remove• require good hygiene practices• may irritate the ear canal• easily misplaced• more difficult to see and monitor usage	<p>Disadvantages:</p> <ul style="list-style-type: none">• less portable and heavier• more inconvenient for use with other personal protective equipment.• more uncomfortable in hot, humid work area• more inconvenient for use in confined work areas• may interfere with the wearing of safety or prescription glasses: wearing glasses results in breaking the seal between the ear muff and the skin and results in decreased hearing protection.

 Partnerships Built on Trust SAFETY & HEALTH MANUAL	4A. Hearing Conservation and Protection	Page 5
	Revision Date: 1/8/2024	Updated

▼ **Noise Exposure Monitoring:**

Engineering controls are insufficient to reduce noise exposures below the “action level” or noise levels are unknown, the following steps must be implemented by Beeler Construction for Beeler employees and must be implemented by all subcontractors of every tier with affected employees.

Sound level measurements, exposure monitoring or existing noise monitoring studies are necessary to identify high noise areas or activities, employees who must be included in the HCP and job positions for which noise controls must be implemented. These activities also enable the proper selection of hearing protectors when they are required.

Sound level measurements generally are to be made using standard calibrated sound level meters. However, at times, meters equipped with octave band filter sets may be needed to measure sound levels at specific frequencies as well as impact noises. The information obtained through sound level measurements should be used to support noise exposure monitoring data, identify noise sources and develop noise control strategies.

Noise exposures should be determined through the use of calibrated audio dosimeters that are worn by the employees. This approach is referred to as personal monitoring. The audio dosimeters continuously measure and integrate sound levels during the work shift. At the end of the monitoring period, the audio dosimeters are removed from the employees and the time-weighted average noise exposures are determined.

When it is more expedient to do so, daily noise exposures may be determined using sound level meters and an area monitoring approach. Generally this is done when employees are exposed to relatively constant noise levels throughout the day or to noise levels predominantly below 85 dBA.

Following initial assessment, personal noise exposure monitoring should be performed as often as necessary to keep the data current and representative of the existing conditions.

When noise exposure monitoring is performed, employees or their authorized representative must be allowed an opportunity to observe the monitoring procedures.

 Partnerships Built on Trust SAFETY & HEALTH MANUAL	4A. Hearing Conservation and Protection	Page 6
	Revision Date: 1/8/2024	Updated

Noise exposure monitoring results are to be documented in writing. All affected employees must be informed of the results by their supervisor. The results should be shown by job position.

Noise exposure monitoring and sound level measurement records shall be retained in the project file and copies sent to the operating group safety director.

▼ **Audiometric Testing:**

Only on projects where required, audiometric testing will be performed when working on employee's who are commonly exposed to noise equal to or greater than 85 dBA on an 8 hour time weighted average. Testing shall be performed by a licensed or professional Audiologist.

For these employees, audiometric testing is to be performed annually.

Within 6 months of an employee's first exposure at or above the action level, a valid baseline shall be established against which future audiograms can be compared.

Testing to establish a baseline audiogram shall be preceded by at least 14 hours without exposure to workplace noise. Hearing protection may be used during this time frame to meet this requirement. Employees shall be notified to avoid hi noise levels during this time frame. When comparing an employee's audiogram results to their baseline audiogram, if the comparison indicates a standard threshold shift, the employee must be notified within 21 days of this determination.

Once an employee experiences a standard threshold shift, the hearing protection types he or she is using will be re-evaluated, hearing protectors shall be refitted, alternate protectors will be tested and the employee will be retrained in hearing conservation and protection.

All audiometric testing records shall be maintained for each employee for the length/term of their employment. These records shall be turned over to the employee when their employment term is completed or when they have been terminated.

▼ **Hearing Protection**

If engineering controls are insufficient to reduce noise exposures below the "action level" and hearing protection is required, the following steps must be implemented by Beeler Construction for Beeler Construction employees and must be implemented by all subcontractors of every tier with affected employees.

Hearing protectors are used to prevent noise-induced hearing loss when engineering controls (e.g., silencers, enclosures, etc.) are either not effective or feasible.

 Partnerships Built on Trust SAFETY & HEALTH MANUAL	4A. Hearing Conservation and Protection	Page 7
	Revision Date: 1/8/2024	Updated

Hearing protectors shall be made available to all employees who request them at no cost to the employees. Employees shall be **required** to wear hearing protectors in all areas where noise levels equal or exceed 85 dBA. Employees are also required to wear hearing protectors when working in job positions/tasks that have noise exposures at or above 85 dBA as an 8-hour average and in all positions with noise exposures exceeding the permissible exposure limit (90 dBA as an 8-hour TWA).

Employee shall be offered a variety of hearing protectors from which to choose a style that is effective and comfortable. Generally, these include expanding foam inserts, molded plastic inserts and/or ear muffs.

When required to be used, hearing protectors must attenuate an employee's noise exposure to an 8-hour TWA below 85 dBA. Therefore, proper selection of a hearing protector, when required, ultimately depends on that hearing protector's effectiveness in the employee's specific noise environment.

When personal noise exposure monitoring results show that hearing protectors are necessary, the minimum acceptable effectiveness for these devices shall be determined on a job position specific basis.

Every employee who uses hearing protectors must receive adequate training on their fitting, use and care.

Where hearing protectors are required to be used, it is the responsibility of supervision to ensure that all affected Beeler Construction employees comply with the requirement and Beeler Construction subcontractors (of any tier) comply with the requirement.

▼ **Access to Information & Records:**

Requests for copies of records made by employees, former employees or employee's representatives should be cleared through Risk Management.

▼ **Program Audits:**

The HCP should be audited periodically to ensure that all aspects are being carried out properly. Audits should cover such things as noise exposure monitoring efforts as needed, hearing protection use and records retention.

 SAFETY & HEALTH MANUAL	Partnerships Built on Trust	4B. Respiratory Protection Program	Page 1
		Revision Date: 1/8/2024	Updated

Respiratory Protection Program

PURPOSE: To provide requirements for the selection, use and maintenance of respiratory protection equipment used to protect employees from harmful concentrations of vapors, mists, dusts, gases and fumes generated during operations performed by Beeler Construction personnel. All respirators used by Beeler Construction employees and subcontractors must comply with OSHA 29 CFR 1920.134 “Respiratory Protection” and must be NIOSH certified/approved.

POLICY: When engineering controls, such as mechanical ventilation, are not sufficient or feasible to control exposure to airborne contaminants, appropriate respiratory protective equipment shall be provided, used and maintained to prevent exposure of employees to unsafe levels of airborne contaminants generated during company operations.

RESPONSIBILITIES:

Program Coordinator:

The Beeler Construction Safety Director is the respiratory protection Program Coordinator. The Program Coordinator is responsible for administering the respiratory protection program and for auditing the program’s effectiveness.

Field Supervision:

Superintendents and/or foremen are responsible for ensuring that employees are properly using and caring for their respiratory protective equipment at all times when required, by conducting periodic inspections of the jobsite.

Employees:

Employees are responsible for using their assigned respirators when performing operations that may produce concentrations of airborne contaminants that exceed permissible exposure limits. Employees are also responsible for properly cleaning and maintaining respirators as trained. Failure to use respirators when required or abuse of assigned respiratory protective equipment can result in disciplinary action.

Subcontractors:

Subcontractors must ensure that their employees are provided with appropriate respiratory protection when exposed to airborne contaminants that cannot be controlled through the use of local ventilation or other techniques. Subcontractors must ensure that all aspects of a respiratory protection program are implemented including employee training, medical evaluation, respirator fit testing, inspection maintenance and repair of respiratory protective equipment and selection of the appropriate respiratory protective device based upon the type and measured concentration of the airborne contaminant.

 Partnerships Built on Trust SAFETY & HEALTH MANUAL	4B. Respiratory Protection Program	Page 2
	Revision Date: 1/8/2024	Updated

PROCEDURES:

Evaluation of Exposure:

Most of the work that Beeler Construction employees perform does not require the use of respiratory protection. For this reason, Beeler Construction offers filtering face piece respirators to its employees as a comfort device to protect against nuisance levels of dust and other debris in the work area. Beeler Construction, therefore, is subject to the voluntary use of respirator provisions of OSHA's Respiratory Protection Standard. These respirators are offered for employee use on a voluntary basis for exposures that fall well below any applicable OSHA permissible exposure limit.

In the event that a Beeler Construction employee is exposed to a substance that exceeds OSHA's PEL, a full respiratory protection program as outlined below will be implemented. Such exposures may occur from work involving high concentrations of respirable dust or silica or fumes that may be encountered during unusual demolition or renovation activities. Where exposures exist that may exceed the PEL, representative air monitoring will be conducted to establish the level of exposure so that the proper type of respirator can be selected.

Respirator Selection:

Respirators shall be provided to protect employees from exposure to:

- ✓ Respirable nuisance dust
- ✓ Silica containing dusts
- ✓ Other airborne contaminants as necessary

For exposure to products obtained and used by Beeler Construction, safety data sheets will be reviewed as new supplies are purchased to evaluate possible exposure to new airborne contaminants. If it is discovered that potential exposure to a new airborne contaminant exists, the proper respirator cartridge shall be obtained to protect against the hazard or air supplied respiratory protection will be used when the concentration is higher than can be protected by cartridge type respirators.

All respirators are provided to employees by Beeler Construction at no cost to the employee.

Silica, Dust:

For exposure to dust, fumes, silica and other particulates, the following respirators and filter media have been selected for use:

- N95, R95 or P95 half-face filtering face piece respirators
- Half-face respirator with 99.7% efficient HEPA filter cartridges (P100)

 Partnerships Built on Trust SAFETY & HEALTH MANUAL	4B. Respiratory Protection Program	Page 3
	Revision Date: 1/8/2024	Updated

Organic Vapors:

- Half-face respirator with organic vapor cartridges (OVA)

Half-face respirators are permitted to be used when the concentration of contaminant does not exceed 10 times the permissible exposure limit (PEL) for silica, dust, or vapor.

If the measured or anticipated PEL for the silica, dust exceeds 10 times the PEL, but is less than 100 times the PEL, the following respirator and filter media have been selected for use:

- Full-face respirator with 99.7% efficient HEPA filter cartridges (P100)

If the measured or anticipated PEL for organic vapor exceeds 10 times the PEL, but is less than 100 times the PEL, the following respirator and filter media have been selected for use:

- Full-face respirator with organic vapor cartridges (OVA)

Operations Where Respirators May be Required to be Used:

Respirators may need to be worn during the following operations, depending on the amount of air contaminant generated during the following operations:

- 1) Grinding on concrete
- 2) Grinding mortar joints
- 3) Dry cutting block and brick
- 4) Dry cutting concrete
- 5) Abrasive blasting of concrete surfaces
- 6) Breaking of concrete with jackhammers
- 7) Mixing of dry mortar
- 8) Cleaning up of dust and debris containing silica
- 9) Grinding on surfaces
- 10) Manual scraping or sanding on surfaces

Medical Evaluations:

No employee will be assigned a respirator unless they have first been evaluated by a physician to determine if they are physically capable of performing the work and using the prescribed respiratory protective equipment. The evaluations shall consist of a medical questionnaire that includes the information contained in OSHA's Respiratory Protection Standard. The physician shall determine if further examination, including spirometry, is medically necessary. The medical evaluation will be performed by a physician selected by Beeler Construction.

 Partnerships Built on Trust SAFETY & HEALTH MANUAL	4B. Respiratory Protection Program	Page 4
	Revision Date: 1/8/2024	Updated

Facial Hair Policy:

Facial hair prevents an effective face to face piece seal of both negative and positive pressure respiratory protective equipment. This condition can allow potentially harmful vapors, mists, fumes and dusts to be inhaled while the respirator is worn. Therefore, no Beeler Construction employee will be allowed to use a respirator if they have a beard, sideburns, goatee, or mustache that interferes with the seal of the respirator. This policy only applies to those tasks that involve the required use of a respirator. Employees that are instructed to perform work, which requires the use of a respirator, that have a beard which interferes with the seal of the respirator, will be instructed to shave or will be assigned other work not involving the use of a respirator.

Assignment, Maintenance and Cleaning of Respirators:

Each employee that will be using a respirator to protect against inhalation of potentially hazardous airborne contaminants shall be assigned a respirator. That employee shall be responsible for periodically cleaning and disinfecting the respirator. No employee shall perform repairs or maintenance on any respirator. Defective or malfunctioning respirators will be returned to a foreman or superintendent for a replacement.

Each employee is responsible for thoroughly cleaning and properly storing their respirator. All cartridges should be removed from the respirator prior to cleaning. After use, respirators should be cleaned in warm soapy water, rinsed, allowed to dry and stored in a plastic bag. The respirator should then be placed in the portable storage container to protect from crushing and damage. No solvent or abrasives should be used to clean the respirator. Special care should be taken to prevent damage to the lens of the full face respirators. The lens of full-face respirators should be cleaned and dried using a soft cloth.

Fit Testing:

Prior to the assignment of the respirator, each employee shall be properly fit tested to ensure an adequate face to face piece seal. The employee shall put the respirator on and adjust to obtain the best seal possible. Fit testing will be conducted prior to initial respirator use and then annually thereafter. Fit test will be documented and records will be maintained.

After the respirator has been properly adjusted, the respirator shall be tested for adequate seal through an irritant smoke tube test (for P-100 particulate cartridges) or banana oil (for organic vapor cartridges). The employee will be required to move his head around, back and forth, and required to speak during the fit test. If the employee indicates the presence of the challenge agent, the respirator shall be re-adjusted to obtain a more adequate seal or replaced with another respirator of a different size. The respirator shall not be assigned until an adequate seal can be obtained. OSHA's fit testing protocol referenced in the appendix to the standard will be followed.

 SAFETY & HEALTH MANUAL	Partnerships Built on Trust	4B. Respiratory Protection Program	Page 5
		Revision Date: 1/8/2024	Updated

Employee Training:

One of the most important elements of the Beeler Construction respiratory protection program is the proper training of its employees that use respiratory protective equipment. The Beeler Construction training program will address the following areas:

- The nature and danger of the airborne contaminant for which respiratory protective equipment will be used.
- A discussion of the possible health effects or signs and symptoms of exposure the employee may experience if the respirator is not used.
- Instruction of the different parts of the respirator including exhalation and inhalation valves, straps, face piece, filter cartridge and breathing air compressor.
- Instruction in the proper method of donning (putting on) and adjusting the respirator.
- Instruction in the user seal check methods after initial fit testing has been performed. The user seal check methods include:
 - ✓ Negative Pressure Test – The employee shall don the respirator and adjust it to obtain the best fit. The employee shall then place their hands over the filter cartridge(s) to prevent the flow of air through the cartridge and inhale. If a negative pressure can be obtained, the respirator has an effective seal and the exhalation valve is functioning properly.
 - ✓ Positive Pressure Test – After the employee performs the negative pressure test above, they should place their hand over the exhalation valve and exhale. If a resistance to exhalation can be detected, the inhalation valves are functioning properly. This test DOES NOT provide evidence of a proper fit.
- Training in the proper cleaning and inspection of respirators after use. Each employee shall be instructed to do the following after each use:
 - ✓ Clean the respirator after each use with soap and water. DO NOT use a solvent to clean the respirator, it could damage the valves and cause it to malfunction during its next use.
 - ✓ Inspect the respirator and valves for damage BEFORE AND AFTER each use and cleaning. Valves should be inspected for damage such as tears or warping. Damaged respirators should be returned to a supervisor for replacement.
 - ✓ Properly store the respirator by placing it in a plastic bag and then in an area free from possible damage by tools, equipment, etc.
- Instruction in methods to determine when a filter cartridge is no longer functioning properly or filtering the contaminant for which it was intended. The methods used to determine if a cartridge is no longer functioning properly include:
 - ✓ Resistance to Breathing – If the employee experiences increased difficulty in breathing detected by an increased resistance in the respirator, this is an indication that the filter cartridge is fouled and ready to be replaced.

 <p>Partnerships Built on Trust</p> <p>SAFETY & HEALTH MANUAL</p>	<p>4B. Respiratory Protection Program</p>	<p>Page 6</p>
	<p>Revision Date: 1/8/2024</p>	<p>Updated</p>

✓ Smelling of Contaminant* – If the employee can smell or taste the contaminant being filtered and the respirator has been properly fitted, this is an indication that the filter cartridge media is fouled and ready to be replaced.

* Relying solely on smelling of the contaminant is not always a reliable method of detecting expiration of the filter cartridge. Some chemicals have odor thresholds that occur at levels much higher than permissible exposure limits, thus exposing the employee to harmful levels before detection can occur. Additionally, some chemicals have poor warning properties as they cannot be detected by sense of smell. In operations involving the use of such chemicals, other methods such as routine replacement of cartridges should be used to ensure proper function of the respirator cartridge media.

- IDLH Conditions (Immediately Dangerous to Life and Health) – Beeler Construction employees shall NEVER work in IDLH conditions, in the event IDLH conditions occur, all employees shall immediately vacate the work area and if required implement the appropriate emergency response. Furthermore, respirators assigned to Beeler Construction employees are not rated for and must NEVER be used in atmospheres which are immediately dangerous to life and health (IDLH). Such conditions include:

- ✓ Oxygen deficient atmospheres

- ✓ Atmospheres in which the concentration of air contaminant is at a level that is lethal upon failure of respiratory protective equipment

- If an employee experiences any changes in breathing resistance, senses vapor/gas breakthrough, or notices leakage of the face piece, he or she should immediately leave the affected work area. Their respirator must be cleaned or replaced and functioning prior to returning to the work area.

Auditing Effectiveness of Respiratory Protection Program:

The Beeler Construction foreman, superintendent or project manager shall periodically audit the effectiveness of the respiratory protection program by ensuring that employees are properly using the respirators assigned to them. This check should include if respirators are being donned correctly, adjusted properly, checked for proper seal, replacement of cartridges when expired, proper cleaning, proper inspection and proper storage of respiratory protective equipment. The foreman should check with the office for the assigned respirator fit for employees working on their jobsite.

 Partnerships Built on Trust	4C. Bloodborne Pathogens	Page 1
	Revision Date: 1/8/2024	Updated
SAFETY & HEALTH MANUAL		

Bloodborne Pathogens-Exposure Control Plan

PURPOSE: The purpose of this procedure is to provide requirements to eliminate or minimize employee exposure to bloodborne pathogens by Beeler Construction employees and employees of subcontractors. This document is a summary of OSHA's comprehensive requirements contained in 29 CFR 1910.1030, and is available for review by all Beeler Construction employees.

POLICY: Beeler Construction provides a safe and healthful workplace for all its employees. This procedure summarizes the main requirements of OSHA's comprehensive bloodborne pathogen requirements. This procedure applies to all jobsites, activities and situations where Beeler Construction employees and subcontractors can be affected by bloodborne pathogens.

TRAINING: All Beeler Construction employees shall receive initial bloodborne pathogen training and annual refresher training. The purpose of the training is to continue Beeler Construction's commitment to providing a safe and healthy work environment by insuring awareness of the risks involved with bloodborne pathogens, how bloodborne diseases are transmitted and their symptoms. Training records of all employees must be kept for 3 years or more.

DEFINITIONS

Bloodborne Pathogens: Any microorganism that is present in human blood and can cause disease in humans. Common serious bloodborne pathogens are Hepatitis B virus (HBV), Hepatitis C virus (HCV) and Human immunodeficiency virus (HIV), which causes acquired immunodeficiency syndrome (AIDS).

Other Potentially Infectious Materials (OPIM): Both blood and OPIM may contain bloodborne pathogens. Some examples of bodily fluids that may contain OPIM's are cerebrospinal fluid, synovial fluid, pleural fluid, pericardial fluid, peritoneal fluid, amniotic fluid, saliva, semen, vaginal secretions, and any bodily fluid that is visibly contaminated with blood.

Exposure Determination: No one is required by Beeler Construction to administer first aid or act as a first aid responder as part of his or her job duties. People are expected to self-administer first aid using the first aid kits provided on each job site. Emergency medical services or the nearest medical provider shall be contacted for injuries beyond first aid. People may also volunteer to administer first aid acting as a "Good Samaritan."



Partnerships
Built on Trust

SAFETY & HEALTH MANUAL

4C. Bloodborne Pathogens

Page
2

Revision Date: 1/8/2024

Updated

Even though our employees do not have an occupational exposure to bloodborne pathogens, but may become exposed while doing "Good Samaritan" acts, Beeler Construction has implemented this control plan to protect the volunteer first aid responders from bloodborne pathogens.

Universal Precautions: Universal precautions will be followed when administering first aid and during cleanup of blood and bodily fluids. "Universal precautions" applies the concept of assuming that all blood and bodily fluids are considered infected with bloodborne pathogens regardless of the individual. Protect yourself from everyone!

Personal Protective Equipment: Use of personal protective equipment (PPE) will be the primary method of exposure control and will be inspected and maintained on a regular basis. Workers administering first aid and during cleanup of blood and bodily fluids will wear appropriate PPE; gloves, masks, safety glasses and apron.

A Universal Precautions Compliance Kit is provided in each first aid kit. This kit contains gloves, safety shield, apron, disinfectant solution, Red-Z pouch, biohazard bag, scoop and scraper and antimicrobial towelette. The instructions on the kit's bag are a good reminder of the necessary precautions. On large projects, more extensive bloodborne pathogen supplies are provided.

All garments that are contaminated by blood shall be removed immediately or as soon as feasible. All PPE will be removed prior to leaving the area where first aid is rendered. Do not take contaminated clothing home to wash.

When PPE is removed, it shall be placed in an appropriate area or container for storage, washing, decontamination or disposal. When possible, contaminated materials used for first aid will be given to responding EMT's for proper disposal.

Handwashing: Handwashing is a simple but very important step for preventing the transmission of bloodborne pathogens. The following general guidelines for handwashing are as follows:

- Wash any exposed skin, ideally with antibacterial soap, as soon as possible after an exposure.
- While washing, be gentle with any scabs or sores.
- Wash hands immediately after removing gloves or other PPE.
- Wash all surfaces, including the backs of hands, wrists, between the fingers, and under fingernails.

Antiseptic towelettes and waterless antibacterial handwashing liquid can be used when soap and running water are not available. If one of these methods is used for the initial cleaning after a potential exposure, you still need to thoroughly wash your hands with soap and water later.



Partnerships
Built on Trust

SAFETY & HEALTH MANUAL

4C. Bloodborne Pathogens

Page
3

Revision Date: 1/8/2024

Updated

If blood or bodily fluids come in contact with your eyes, nose, lips (mucous membranes), immediately flush the area with running water for 20 minutes.

Hepatitis B Vaccines: Beeler Construction will offer the Hepatitis B vaccination series at no cost to any employee after an exposure incident.

Occupational Exposure Incident: An exposure incident is when blood or other potentially infectious material gets into your eye, mouth or any other mucous membrane or if it comes in contact with non-intact skin. If you stick yourself with a contaminated sharp object, that is an exposure incident also. Remember – hepatitis can survive on surfaces, dried and at room temperature at least one week.

After an exposure incident, the following protocol applies:

- 1) Immediately flood the exposed area with water and wash with antibacterial soap and water or use skin disinfectant. When blood or bodily fluids come in contact with your eyes, nose, lips (mucous membranes), immediately flush the area with running water for 20 minutes.
- 2) Immediately contact the Safety and Health Director to report the incident.
- 3) The exposed employee will be offered a confidential post-exposure evaluation and follow-up. It is important to have this evaluation immediately after the exposure, certainly within 8 hours. Beeler Construction will offer post exposure follow-up at no cost to employees. See below for details.
- 4) The Safety and Health Director investigates the incident and completes an Exposure Incident Report form (attached).

Post-Exposure Evaluation and Follow-Up: The exposed employee post exposure evaluation and follow up will include the following:

- 1) Documentation of route of exposure and circumstances under which the exposure incident occurred.
- 2) Identification and documentation of source individual.
- 3) If the source individual provides consent for blood testing, his/her blood shall be tested immediately. If the source individual does not provide consent or is unable to give consent, the medical provider will discuss risk options, blood testing and vaccinations. If an employee chooses to decline the vaccinations, he/she needs to sign a form indicating they do not want it at this time.
- 4) Results of source individual's testing shall be made available to exposed employee, and employee shall be informed of applicable laws and regulations concerning disclosure of identity and infectious status of the source individual.
- 5) Medical records for employees exposed to bloodborne pathogen events must be kept for the duration of employment plus 30 years.



Partnerships
Built on Trust

SAFETY & HEALTH MANUAL

4C. Bloodborne Pathogens

Page
4

Revision Date: 1/8/2024

Updated

Cleanup and Decontamination: For cleaning up after minor first aid injuries, the injured person is responsible for cleaning up their own blood and bodily fluids using the Universal Precautions Compliance kit provided in the first aid kit. You bleed-you clean!

For larger biohazard spills:

- 1) Secure the area: Cordon off the area with caution tape and assign an attendant to direct people away from the contaminated area until the area is cleaned.
- 2) Wear appropriate PPE: gloves, mask, safety glasses and apron.
- 3) Wipe up small spills with paper towels.
- 4) Clean up larger spills using Red-Z fluid solidifier (kitty litter as a substitute) and sweep up with broom and dust pan/scoop.
- 5) Disinfect the area and equipment with a freshly prepared 10% bleach solution. Soak the area for at least 20 minutes with the disinfectant. You can be liberal with the disinfectant, but don't apply so heavily that it begins to run. One cup bleach and 9 cups water. Be careful when handling bleach. Bleach is a corrosive that can burn the skin and damage the eyes on contact. If you get bleach on your skin, immediately flush the area with water.
- 6) Place all contaminated clean up materials (towels, PPE) in a red biohazard bag and secure tightly.
- 7) Remove gloves, mask, safety glasses, apron and discard in biohazard bag.
- 8) Clean and disinfect clean up materials with a 10% bleach solution; mops, brooms, dust pans.
- 9) Thoroughly wash hands with soap and water immediately when finished.
- 10) Contact the Safety Director to report the incident.

Waste Disposal: Place all contaminated materials in a red biohazard bag with proper labels and close tightly. Do not put loose sharps in the biohazard bag. Blood and other potentially infectious materials are considered regulated waste. When possible, give the biohazard bag to the EMT's for disposal; otherwise contact the Safety Director for instructions on proper disposal. Red Z fluid solidifier decontaminates blood and bodily fluids. It is non-hazardous and can be disposed as general waste.

Recordkeeping: The Safety Director is responsible for maintaining medical records in accordance with OSHA Standard 29 CFR 1910.20. These records shall be kept confidential, and must be maintained for the duration of the employee's employment plus 30 years.

Evaluation and Review: The Safety Director is responsible for reviewing this program for effectiveness and updating as needed.



Partnerships
Built on Trust

4C. Bloodborne Pathogens

Page
5

SAFETY & HEALTH MANUAL

Revision Date: 1/8/2024

Updated

BIOHAZARD SPILL CLEANUP PROCEDURE:

- 1) Secure the area: Cordon off the area with caution tape and assign an attendant to direct people away from the contaminated area until the area is cleaned.
- 2) Wear appropriate PPE: gloves, mask, safety glasses and apron.
- 3) Wipe up small spills with paper towels.
- 4) Clean up larger spills using Red-Z fluid solidifier (kitty litter as a substitute) and sweep up with broom and dust pan/scoop.
- 5) Disinfect the area and equipment with a freshly prepared 10% bleach solution. Soak the area for at least 20 minutes with the disinfectant. You can be liberal with the disinfectant, but don't apply so heavily that it begins to run. One cup bleach and 9 cups water. Be careful when handling bleach. Bleach is a corrosive that can burn the skin and damage the eyes on contact. If you get bleach on your skin, immediately flush the area with water.
- 6) Place all contaminated clean up materials (towels, PPE) in a red biohazard bag and secure tightly.
- 7) Remove gloves, mask, safety glasses, apron and discard in biohazard bag.
- 8) Clean and disinfect clean up materials with a 10% bleach solution; mops, brooms, dust pans.
- 9) Thoroughly wash hands with soap and water immediately when finished.
- 10) Contact the Safety Director to report the incident.

Proper Removal of Gloves:



With gloved dominant hand, grasp the other glove at the wrist or palm and pull it away from hand.



Pull the glove the rest of the way off.

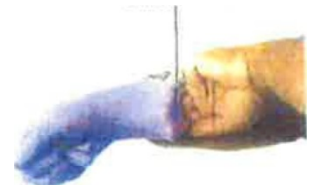

Holding the removed glove balled up in palm of your gloved hand, insert fingers your non-dominant hand under the cuff of the remaining glove.

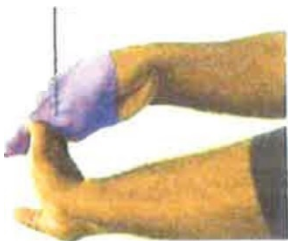

Remove the glove by stretching it up and away from the hand that turned it inside out as you pull off.



Dispose of gloves in a biohazard container and wash hands.



Partnerships
Built on Trust

**4C. Bloodborne
Pathogens**

**Page
6**

SAFETY & HEALTH MANUAL

Revision Date: 1/8/2024

Updated

BEELER CONSTRUCTION, INC.
BLOODBORNE PATHOGENS
EXPOSURE INCIDENT REPORT FORM

Employee

Foreman

Date of Incident/Accident

Time

Job Name

Describe the incident fully: (route of exposure, circumstances; describe type of controls in place at time of incident including engineering controls and personal protective equipment worn; identify unsafe conditions and/or actions; relevant police reports).

Describe employee's injury: (part of the body/type of injury)

Describe first aid/medical treatment: (when and by whom)

When was the incident reported? _____ To Whom? _____

If not immediately reported, why? _____

List names of witnesses: _____

Is the source individual known? Yes _____ No _____ If yes, please provide name/address so that consent for blood testing can be obtained.

Name: _____ Address: _____

Beeler Construction, Inc.
Bloodborne Pathogens
Exposure Incident Report Form
Page 2

Did the source consent to blood draw and testing?

Yes _____ No _____

What corrective action was taken or is planned to prevent similar accidents from occurring in the future?

Referral to medical evaluator?

Yes _____ No _____

If no, explain: _____

Name of investigator: _____ Title: _____

Date: _____

BEELER CONSTRUCTION, INC.
HEPATITIS B VACCINE
DECLINATION FORM

I understand that due to my occupational exposure to blood or other potentially infectious materials, I may be at risk of acquiring Hepatitis B virus (HBV) infection. I have been given the opportunity to be vaccinated with Hepatitis B vaccine at no charge to me. However, I decline Hepatitis B vaccination at this time. I understand that by declining this vaccine, I continue to be at risk of acquiring Hepatitis B, a serious disease. In the future, I continue to have occupational exposure to blood or other potentially infectious materials and I want to be vaccinated with Hepatitis B vaccine, I can receive the vaccination series at no charge to me.

Employee

Signature

Date

Supervisor

Signature

Date

 Partnerships Built on Trust	4D. Silica Program	Page 1
	Revision Date: 1/8/2024	Updated
SAFETY & HEALTH MANUAL		

Respirable Crystalline Silica Program

Purpose

This Respirable Crystalline Silica Program was developed to prevent employee exposure to hazardous levels of Respirable Crystalline Silica that could result through construction activities or nearby construction activities occurring on worksites. Respirable Crystalline Silica exposure at hazardous levels can lead to lung cancer, silicosis, chronic obstructive pulmonary disease, and kidney disease. It is intended to meet the requirements of the Respirable Crystalline Silica Construction Standard (29 CFR 1926.1153) established by the Occupational Safety and Health Administration (OSHA).

All work involving chipping, cutting, drilling, grinding, or similar activities on materials containing Crystalline Silica can lead to the release of respirable-sized particles of Crystalline Silica (i.e. Respirable Crystalline Silica). Crystalline Silica is a basic component of soil, sand, granite and many other minerals. Quartz is the most common form of Crystalline Silica. Many materials found on construction sites include Crystalline Silica; including but not limited to – cement, concrete, asphalt, pre-formed structures (inlets, pipe, etc.) and others. Consequently, this program has been developed to address and control these potential exposures to prevent our employees from experiencing the effects of occupational illnesses related to Respirable Crystalline Silica exposure.

Scope

This Respirable Crystalline Silica Program applies to all employees who have the potential to be exposed to Respirable Crystalline Silica when covered by the OSHA Standard. The OSHA Respirable Crystalline Silica Construction Standard applies to all occupational exposures to Respirable Crystalline Silica in construction work, except where employee exposure will remain below 25 micrograms of Respirable Crystalline Silica per cubic meter of air (25 µg/m³) as an 8-hour time-weighted average (TWA) under any foreseeable conditions.

Responsibilities

Beeler Construction firmly believes protecting the health and safety of our employees is everyone's responsibility. This responsibility begins with upper management providing the necessary support to properly implement this program. However, all levels of the organization assume some level of responsibility for this program including the following positions.

- Conduct job site assessments for Silica containing materials and perform employee Respirable Crystalline Silica hazard assessments in order to determine if an employee's exposure will be above 25 µg/m³ as an 8-hour TWA under any foreseeable conditions.
- Select and implement into the project's ECP the appropriate control measures in accordance with the Construction Tasks identified in OSHA's Construction Standard Table 1; and potentially including (but not limited to) - a written Exposure Control Plan (ECP), exposure monitoring, Hazard Communication training, medical surveillance, housekeeping and others.

NOTE: OSHA's Construction Standard Table 1 is a list of 18 common construction tasks along with acceptable exposure control methods and work practices that limit exposure for those tasks. Beeler Construction tools, (i.e. drills and core drills) are listed in OSHA's Table 1 and shall be able to use this table, exactly as listed, for most of their work.

 Partnerships Built on Trust	4D. Silica Program	Page 2
	Revision Date: 1/8/2024	Updated

SAFETY & HEALTH MANUAL

- Ensure that the materials, tools, equipment, personal protective equipment (PPE), and other resources (such as worker training) required to fully implement and maintain this Respirable Crystalline Silica Program are in place and readily available if needed.
- Ensure that Project Managers, Site Managers, Competent Persons, and employees are educated in the hazards of Silica exposure and trained to work safely with Silica in accordance with OSHA's Respirable Crystalline Silica Construction Standard and OSHA's Hazard Communication Standard. Managers and Competent Persons may receive more advanced training than other employees.
- Maintain written records of training (for example, proper use of respirators), ECPs, inspections (for equipment, PPE, and work methods/practices), medical surveillance (under lock and key), respirator medical clearances (under lock and key) and fit-test results.
- Conduct an annual review (or more often if conditions change) of the effectiveness of this program and any active project ECP's that extend beyond a year. This includes a review of available dust control technologies to ensure these are selected and used when practical.
- Coordinate work with other employers and contractors to ensure a safe work environment relative to Silica exposure.
- Ensure all applicable elements of this Respirable Crystalline Silica Program are implemented on the project including the selection of a Competent Person.
- Assist the Safety Department in conduct job site assessments for Silica containing materials and perform employee Respirable Crystalline Silica hazard assessments in order to determine if an ECP, exposure monitoring, and medical surveillance is necessary.
- Assist in the selection and implementation of the appropriate control measures in accordance with the Construction Tasks identified in OSHA's Construction Standard Table 1; and potentially including (but not limited to) - a written Exposure Control Plan (ECP), exposure monitoring, Hazard Communication training, medical surveillance, housekeeping and others.
- Ensure that employees using respirators have been properly trained, medically cleared, and fit-tested in accordance with the Beeler Construction's Respiratory Protection Program. This process will be documented.
- Ensure that work is conducted in a manner that minimizes and adequately controls the risk to workers and others. This includes ensuring that workers use appropriate engineering controls, work practices, and wear the necessary PPE.
- Where there is risk of exposure to Silica dust, verify employees are properly trained on the applicable contents of this program, the project-specific ECP, and the applicable OSHA Standards (such as Hazard Communication). Ensure employees are provided appropriate PPE when conducting such work.

 Partnerships Built on Trust SAFETY & HEALTH MANUAL	4D. Silica Program	Page 3
	Revision Date: 1/8/2024	Updated

Competent Person and/or Site Manager (Superintendent, Foreman, etc.)

- Make frequent and regular inspections of job sites, materials, and equipment to implement the written ECP.
- Identify existing and foreseeable Respirable Crystalline Silica hazards in the workplace and take prompt corrective measures to eliminate or minimize them.
- Notify the Project Manager and/or Safety Department of any deficiencies identified during inspections in order to coordinate and facilitate prompt corrective action.
- Assist the Project Manager and Safety Department in conducting job site assessments for Silica containing materials and perform employee Respirable Crystalline Silica hazard assessments in order to determine if an ECP, exposure monitoring, and medical surveillance is necessary.

Employees

- Follow recognized work procedures (such as the Construction Tasks identified in OSHA's Construction Standard Table 1) as established in the project's ECP and this program.
- Use the assigned PPE in an effective and safe manner.
- Participate in Respirable Crystalline Silica exposure monitoring and the medical surveillance program.
- Report any unsafe conditions or acts to the Site Manager and/or Competent Person.
- Report any exposure incidents or any signs or symptoms of Silica illness.

Definitions

If a definition is not listed in this section, please contact your supervisor. If your supervisor is unaware of what the term means, please contact the Competent Person or your Safety Department.

- Action Level means a concentration of airborne Respirable Crystalline Silica of 25 $\mu\text{g}/\text{m}^3$, calculated as an 8-hour TWA.
- Competent Person means an individual who is capable of identifying existing and foreseeable Respirable Crystalline Silica hazards in the workplace and who has authorization to take prompt corrective measures to eliminate or minimize them.
- Employee Exposure means the exposure to airborne Respirable Crystalline Silica that would occur if the employee were not using a respirator.
- High-Efficiency Particulate Air (HEPA) Filter means a filter that is at least 99.97 percent efficient in removing monodispersed particles of 0.3 micrometers in diameter.

 Partnerships Built on Trust	4D. Silica Program	Page 4
	Revision Date: 1/8/2024	Updated
SAFETY & HEALTH MANUAL		

- Objective Data means information, such as air monitoring data from industry-wide surveys or calculations based on the composition of a substance, demonstrating employee exposure to Respirable Crystalline Silica associated with a particular product or material or a specific process, task, or activity. The data must reflect workplace conditions closely resembling or with a higher exposure potential than the processes, types of material, control methods, work practices, and environmental conditions in the employer's current operations.
- Permissible Exposure Limit (PEL) means the employer shall ensure that no employee is exposed to an airborne concentration of Respirable Crystalline Silica in excess of 50 $\mu\text{g}/\text{m}^3$, calculated as an 8-hour TWA.
- Physician or Other Licensed Health Care Professional (PLHCP) means an individual whose legally permitted scope of practice (i.e., license, registration, or certification) allows him or her to independently provide or be delegated the responsibility to provide some or all of the particular health care services required by the Medical Surveillance Section of the OSHA Respirable Crystalline Silica Standard.
- Respirable Crystalline Silica means Quartz, Cristobalite, and/or Tridymite contained in airborne particles that are determined to be respirable by a sampling device designed to meet the characteristics for respirable-particle size- selective samplers specified in the International Organization for Standardization (ISO) 708:1995: Air Quality-Particle Size Fraction Definitions for Health-Related Sampling.
- Specialist means an American Board Certified Specialist in Pulmonary Disease or an American Board Certified Specialist in Occupational Medicine.

Requirements

Specified Exposure Control Methods

When possible and applicable, Beeler Construction will conduct activities with potential Silica exposure to be consistent with OSHA's Construction Standard Table 1. Supervisors will ensure each employee under their supervision and engaged in a task identified on OSHA's Construction Standard Table 1 have fully and properly implemented the engineering controls, work practices, and respiratory protection specified for the task on Table 1 (unless Beeler Construction has assessed and limited the exposure of the employee to Respirable Crystalline Silica in accordance with the Alternative Exposure Control Methods Section of this program).

The task(s) being performed by Beeler Construction identified on OSHA's Construction Standard Table 1 is/are: Select any/all of the following that apply:



Partnerships
Built on Trust

SAFETY & HEALTH MANUAL









4D. Silica Program

**Page
5**

Revision Date: 1/8/2024

Updated

Table 1: Specified Exposure Control Methods When Working With Materials Containing Crystalline Silica

Equipment/Task	Engineering and Work Practice Control Methods	Respirator Requirements and Minimum Assigned Protection Factor (APF) for 4 Hours or Less	Respirator Requirements and Minimum Assigned Protection Factor (APF) for More Than 4 Hours
<p>Handheld power saws (any blade diameter)</p> 	<ul style="list-style-type: none"> Use saw equipped with integrated water delivery system that continuously feeds water to the blade. Operate and maintain tool in accordance with manufacturer's instructions to minimize dust emissions: 	<p>- When used outdoors</p>  <p>(None required)</p>	  <p>(APF 10 required)</p>
	<p>- When used indoors or in an enclosed area</p>	  <p>(APF 10 required)</p>	  <p>(APF 10 required)</p>



Partnerships
Built on Trust

SAFETY & HEALTH MANUAL





4D. Silica Program

**Page
6**

Revision Date: 1/8/2024

Updated

Table 1: Specified Exposure Control Methods When Working With Materials Containing Crystalline Silica

Equipment/Task	Engineering and Work Practice Control Methods	Respirator Requirements and Minimum Assigned Protection Factor (APF) for 4 Hours or Less	Respirator Requirements and Minimum Assigned Protection Factor (APF) for More Than 4 Hours
<p>Walk-behind saws</p> 	<ul style="list-style-type: none"> • Use saw equipped with integrated water delivery system that continuously feeds water to the blade. • Operate and maintain tool in accordance with manufacturer's instructions to minimize dust emissions: 	<p>- When used outdoors</p>  <p>(None required)</p> <p>- When used indoors or in an enclosed area</p>  <p>(APF 10 required)</p>	<p>- When used outdoors</p>  <p>(None required)</p> <p>- When used indoors or in an enclosed area</p>  <p>(APF 10 required)</p>



Partnerships
Built on Trust

SAFETY & HEALTH MANUAL



4D. Silica Program



**Page
7**

Revision Date: 1/8/2024

Updated

Table 1: Specified Exposure Control Methods When Working With Materials Containing Crystalline Silica

Equipment/Task	Engineering and Work Practice Control Methods	Respirator Requirements and Minimum Assigned Protection Factor (APF) for 4 Hours or Less	Respirator Requirements and Minimum Assigned Protection Factor (APF) for More Than 4 Hours
<p>Rig-mounted core saws or drills</p> 	<ul style="list-style-type: none"> • Use tool equipped with integrated water delivery system that supplies water to cutting surface. • Operate and maintain tool in accordance with manufacturer's instructions to minimize dust emissions. 	 <p>(None required)</p>	 <p>(None required)</p>

Equipment/Task	Engineering and Work Practice Control Methods	Respirator Requirements and Minimum Assigned Protection Factor (APF) for 4 Hours or Less	Respirator Requirements and Minimum Assigned Protection Factor (APF) for More Than 4 Hours
<p>Handheld and stand-mounted drills (including impact and rotary hammer drills)</p> 	<ul style="list-style-type: none"> • Use drill equipped with commercially available shroud or cowling with dust collection system. • Operate and maintain tool in accordance with manufacturer's instructions to minimize dust emissions. • Dust collector must provide the airflow recommended by the tool manufacturer, or greater, and have a filter with 99% or greater efficiency and a filter-cleaning mechanism. • Use a HEPA-filtered vacuum when cleaning holes. 	 <p>(None required)</p>	 <p>(None required)</p>



Partnerships
Built on Trust

SAFETY & HEALTH MANUAL







4D. Silica Program

**Page
8**

Revision Date: 1/8/2024

Updated

Table 1: Specified Exposure Control Methods When Working With Materials Containing Crystalline Silica

Equipment/Task	Engineering and Work Practice Control Methods	Respirator Requirements and Minimum Assigned Protection Factor (APF) for 4 Hours or Less	Respirator Requirements and Minimum Assigned Protection Factor (APF) for More Than 4 Hours
<p>Jackhammers and handheld powered chipping tools</p> 	<p>Use tool with water delivery system that supplies a continuous stream or spray of water at the point of impact:</p> <p>- When used outdoors</p> <p>- When used indoors or in an enclosed area</p>	<p>(None required)</p>  <p>(APF 10 required)</p> 	 <p>(APF 10 required)</p>   



Partnerships
Built on Trust

SAFETY & HEALTH MANUAL









4D. Silica Program

**Page
9**

Revision Date: 1/8/2024

Updated

Table 1: Specified Exposure Control Methods When Working With Materials Containing Crystalline Silica

Equipment/Task	Engineering and Work Practice Control Methods	Respirator Requirements and Minimum Assigned Protection Factor (APF) for 4 Hours or Less	Respirator Requirements and Minimum Assigned Protection Factor (APF) for More Than 4 Hours
<p>Jackhammers and handheld powered chipping tools</p> 	<p>OR</p> <ul style="list-style-type: none"> • Use tool equipped with commercially available shroud and dust collection system. • Operate and maintain tool in accordance with manufacturer's instructions to minimize dust emissions. • Dust collector must provide the airflow recommended by the tool manufacturer, or greater, and have a filter with 99% or greater efficiency and a filter-cleaning mechanism: 		
	<p>- When used outdoors</p>	 <p>(None required)</p>	  <p>(APF 10 required)</p>
	<p>- When used indoors or in an enclosed area</p>	  <p>(APF 10 required)</p>	  <p>(APF 10 required)</p>

 Partnerships Built on Trust	4D. Silica Program	Page 10
	Revision Date: 1/8/2024	Updated
SAFETY & HEALTH MANUAL		

When implementing the control measures specified in Table 1, Beeler Construction shall:

- For tasks performed indoors or in enclosed areas, provide a means of exhaust as needed to minimize the accumulation of visible airborne dust;
- For tasks performed using wet methods, apply water at flow rates sufficient to minimize release of visible dust;
- For measures implemented that include an enclosed cab or booth, ensure that the enclosed cab or booth:
 - Is maintained as free as practicable from settled dust;
 - Has door seals and closing mechanisms that work properly;
 - Has gaskets and seals that are in good condition and working properly;
 - Is under positive pressure maintained through continuous delivery of fresh air;
 - Has intake air that is filtered through a filter that is 95% efficient in the 0.3-10.0 µm range (e.g., MERV-16 or better); and
 - Has heating and cooling capabilities.
- Where an employee performs more than one task included on OSHA's Construction Standard Table 1 during the course of a shift, and the total duration of all tasks combined is more than four hours, the required respiratory protection for each task is the respiratory protection specified for more than four hours per shift. If the total duration of all tasks on Table 1 combined is less than four hours, the required respiratory protection for each task is the respiratory protection specified for less than four hours per shift.

Alternative Exposure Control Methods

Alternative Exposure Control Methods apply for tasks not listed in OSHA's Construction Standard Table 1, or where Beeler Construction cannot fully and properly implement the engineering controls, work practices, and respiratory protection described in Table 1.

First, Beeler Construction will assess the exposure of each employee who is or may reasonably be expected to be exposed to Respirable Crystalline Silica at or above the Action Level in accordance with either the Performance Option or the Scheduled Monitoring Option.

- **Performance Option:**
 - Beeler Construction will assess the 8-hour TWA exposure for each employee on the basis of any combination of air monitoring data or objective data sufficient to accurately characterize employee exposures to Respirable Crystalline Silica.

 Partnerships Built on Trust	4D. Silica Program	Page 11
	Revision Date: 1/8/2024	Updated
SAFETY & HEALTH MANUAL		

- **Scheduled Monitoring Option:**

- Beeler Construction will perform initial monitoring to assess the 8-hour TWA exposure for each employee on the basis of one or more personal breathing zone air samples that reflect the exposures of employees on each shift, for each job classification, and in each work area. Where several employees perform the same tasks on the same shift and in the same work area, Beeler Construction will plan to monitor a representative fraction of these employees. When using representative monitoring, Beeler Construction will sample the employee(s) who are expected to have the highest exposure to Respirable Crystalline Silica.
- If initial monitoring indicates that employee exposures are below the Action Level, Beeler Construction will probably discontinue monitoring for those employees whose exposures are represented by such monitoring.
- Where the most recent exposure monitoring indicates that employee exposures are at or above the Action Level but at or below the PEL, Beeler Construction will repeat such monitoring within six months of the most recent monitoring.
- Where the most recent exposure monitoring indicates that employee exposures are above the PEL, Beeler Construction will repeat such monitoring within three months of the most recent monitoring.
- Where the most recent (non-initial) exposure monitoring indicates that employee exposures are below the Action Level, Beeler Construction will repeat such monitoring within six months of the most recent monitoring until two consecutive measurements, taken seven or more days apart, are below the Action Level, at which time Beeler Construction will probably discontinue monitoring for those employees whose exposures are represented by such monitoring, except when a reassessment is required. Beeler Construction will reassess exposures whenever a change in the production, process, control equipment, personnel, or work practices may reasonably be expected to result in new or additional exposures at or above the Action Level, or when Beeler Construction has any reason to believe that new or additional exposures at or above the Action Level have occurred.

Beeler Construction will ensure that all Respirable Crystalline Silica samples taken to satisfy the monitoring requirements of this program and OSHA are collected by a qualified individual (i.e. a Certified Industrial Hygienist) and the samples are evaluated by a qualified laboratory (i.e. accredited to ANS/ISO/IEC Standard 17025:2005 with respect to Crystalline Silica analyses by a body that is compliant with ISO/IEC Standard 17011:2004 for implementation of quality assessment programs).

Within five working days after completing an exposure assessment, Beeler Construction will individually notify each affected employee in writing of the results of that assessment or post the results in an appropriate location accessible to all affected employees.

 Partnerships Built on Trust	4D. Silica Program	Page 12
	Revision Date: 1/8/2024	Updated
SAFETY & HEALTH MANUAL		

Whenever an exposure assessment indicates that employee exposure is above the PEL, Beeler Construction will describe in the written notification the corrective action being taken to reduce employee exposure to or below the PEL.

Where air monitoring is performed, Beeler Construction will provide affected employees or their designated representatives an opportunity to observe any monitoring of employee exposure to Respirable Crystalline Silica. When observation of monitoring requires entry into an area where the use of protective clothing or equipment is required for any workplace hazard, Beeler Construction will provide the observer with protective clothing and equipment at no cost and shall ensure that the observer uses such clothing and equipment.

Once air monitoring has been performed, Beeler Construction will determine its method of compliance based on the monitoring data and the hierarchy of controls. Beeler Construction will use engineering and work practice controls to reduce and maintain employee exposure to Respirable Crystalline Silica to or below the PEL, unless Beeler Construction can demonstrate that such controls are not feasible. Wherever such feasible engineering and work practice controls are not sufficient to reduce employee exposure to or below the PEL, Beeler Construction will nonetheless use them to reduce employee exposure to the lowest feasible level and shall supplement them with the use of respiratory protection.

Control Methods

Beeler Construction will provide control methods that are either consistent with Table 1 or otherwise minimize worker exposures to Silica. These exposure control methods can include engineering controls, work practices, and respiratory protection. Listed below are control methods to be used when Table 1 is not followed:

Respiratory Protection

Where respiratory protection is required by this program, Beeler Construction will provide each employee an appropriate respirator that complies with the requirements of Beeler Construction's Respiratory Protection Program and the OSHA Respiratory Protection Standard (29 CFR 1910.134).

Respiratory protection is required where specified by the OSHA Construction Standard Table 1, for tasks not listed in Table 1, or where Beeler Construction has not fully and properly implemented the engineering controls, work practices, and respiratory protection described in Table 1. Situations requiring respiratory protection include:

- Where exposures exceed the PEL during periods necessary to install or implement feasible engineering and work practice controls;
- Where exposures exceed the PEL during tasks, such as certain maintenance and repair tasks, for which engineering and work practice controls are not feasible; and
- During tasks for which an employer has implemented all feasible engineering and work practice controls and such controls are not sufficient to reduce exposures to or below the PEL.

 Partnerships Built on Trust SAFETY & HEALTH MANUAL	4D. Silica Program	Page 13
	Revision Date: 1/8/2024	Updated

Housekeeping

Beeler Construction does not allow dry sweeping or dry brushing where such activity could contribute to employee exposure to Respirable Crystalline Silica unless wet sweeping, HEPA-filtered vacuuming, or other methods that minimize the likelihood of exposure are not feasible.

Beeler Construction does not allow compressed air to be used to clean clothing or surfaces where such activity could contribute to employee exposure to Respirable Crystalline Silica unless:

- The compressed air is used in conjunction with a ventilation system that effectively captures the dust cloud created by the compressed air; or
- No alternative method is feasible.

Written Exposure Control Plan

When employee exposure on a construction project is expected to be at or above the Action Level, a Written Exposure Control Plan (ECP) will be established and implemented. This ECP will contain at least the following elements:

- A description of the tasks in the workplace that involve exposure to Respirable Crystalline Silica;
- A description of the engineering controls, work practices, and respiratory protection used to limit employee exposure to Respirable Crystalline Silica for each task;
- A description of the housekeeping measures used to limit employee exposure to Respirable Crystalline Silica; and
- A description of the procedures used to restrict access to work areas, when necessary, to minimize the number of employees exposed to Respirable Crystalline Silica and their level of exposure, including exposures generated by other employers or sole proprietors.

The written ECP will designate a Competent Person to make frequent and regular inspections of job sites, materials, and equipment to ensure the ECP is implemented.

The written ECP will be reviewed at least annually to evaluate the effectiveness of it and update it as necessary. Having said this, ECP's are project specific and most project durations do not exceed a year. The written ECP will be readily available for examination and copying, upon request, to each employee covered by this program and/or ECP, their designated representatives, and OSHA.

 Partnerships Built on Trust SAFETY & HEALTH MANUAL	4D. Silica Program	Page 14
	Revision Date: 1/8/2024	Updated

Medical Surveillance

Medical surveillance will be made available for each employee who will be required to use a respirator for 30 or more days per year due to their Respirable Crystalline Silica exposure. Beeler Construction has reviewed their type and scopes of work and DO NOT foresee requiring their employees to wear respirators for more than 30 days per year. Medical surveillance (i.e. medical examinations and procedures) will be performed by a PLHCP and provided at no cost to the employee at a reasonable time and place.

Beeler Construction will make available an initial (baseline) medical examination within 30 days after initial assignment, unless the employee has received a medical examination that meets the requirements of the OSHA Respirable Crystalline Silica Construction Standard within the last three years. The examination shall consist of:

- A medical and work history, with emphasis on past, present, and anticipated exposure to Respirable Crystalline Silica, dust, and other agents affecting the respiratory system in addition to any history of respiratory system dysfunction, including signs and symptoms of respiratory disease (e.g., shortness of breath, cough, wheezing), history of tuberculosis, and smoking status and history;
- A physical examination with special emphasis on the respiratory system;
- A chest X-ray (a single posterior-anterior radiographic projection or radiograph of the chest at full inspiration recorded on either film [no less than 14 x 17 inches and no more than 16 x 17 inches] or digital radiography systems) interpreted and classified according to the International Labor Office (ILO) International Classification of Radiographs of Pneumoconiosis by a NIOSH-certified B Reader;
- A pulmonary function test to include forced vital capacity (FVC) and forced expiratory volume in one second (FEV1) and FEV1/FVC ratio, administered by a spirometry technician with a current certificate from a NIOSH-approved spirometry course;
- Testing for latent tuberculosis infection; and
- Any other tests deemed appropriate by the PLHCP.

Beeler Construction will make available medical examinations that include the aforementioned procedures (except testing for latent tuberculosis infection) at least every three years. If recommended by the PLHCP, periodic examinations can be more frequently than every three years.

 Partnerships Built on Trust SAFETY & HEALTH MANUAL	4D. Silica Program	Page 15
	Revision Date: 1/8/2024	Updated

Beeler Construction will ensure that the examining PLHCP has a copy of the OSHA Respirable Crystalline Silica Construction Standard, this program, and the following information:

- A description of the employee's former, current, and anticipated duties as they relate to the employee's occupational exposure to Respirable Crystalline Silica;
- The employee's former, current, and anticipated levels of occupational exposure to Respirable Crystalline Silica;
- A description of any personal protective equipment (PPE) used or to be used by the employee, including when and for how long the employee has used or will use that equipment; and
- Information from records of employment-related medical examinations previously provided to the employee and currently within the control of Beeler Construction.

Beeler Construction will ensure that the PLHCP explains to the employee the results of the medical examination and provides each employee with a written medical report within 30 days of each medical examination performed. The written report shall contain:

- A statement indicating the results of the medical examination, including any medical condition(s) that would place the employee at increased risk of material impairment to health from exposure to Respirable Crystalline Silica and any medical conditions that require further evaluation or treatment;
- Any recommended limitations on the employee's use of respirators;
- Any recommended limitations on the employee's exposure to Respirable Crystalline Silica; and;
- A statement that the employee should be examined by a Specialist if the chest X-ray is classified as 1/0 or higher by the B Reader, or if referral to a Specialist is otherwise deemed appropriate by the PLHCP.

Beeler Construction will also obtain a written medical opinion from the PLHCP within 30 days of the medical examination. The written opinion shall contain only the following in order to protect the employee's privacy:

- The date of the examination;
- A statement that the examination has met the requirements of the OSHA Respirable Crystalline Silica Construction Standard; and
- Any recommended limitations on the employee's use of respirators.

 Partnerships Built on Trust	4D. Silica Program	Page 16
	Revision Date: 1/8/2024	Updated
SAFETY & HEALTH MANUAL		

If the employee provides written authorization, the written opinion shall also contain either or both of the following:

- Any recommended limitations on the employee's exposure to Respirable Crystalline Silica; and/or
- A statement that the employee should be examined by a Specialist if the chest X-ray is classified as 1/0 or higher by the B Reader, or if referral to a Specialist is otherwise deemed appropriate by the PLHCP.

If the PLHCP's written medical opinion indicates that an employee should be examined by a Specialist, Beeler Construction will make available a medical examination by a Specialist within 30 days after receiving the PLHCP's written opinion. Beeler Construction will ensure that the examining Specialist is provided with all of the information that the employer is obligated to provide to the PLHCP.

Beeler Construction will ensure that the Specialist explains to the employee the results of the medical examination and provides each employee with a written medical report within 30 days of the examination. The written report will contain:

- A statement indicating the results of the medical examination, including any medical condition(s) that would place the employee at increased risk of material impairment to health from exposure to Respirable Crystalline Silica and any medical conditions that require further evaluation or treatment;
- Any recommended limitations on the employee's use of respirators; and
- Any recommended limitations on the employee's exposure to respirable crystalline Silica.

In addition, Beeler Construction will obtain a written opinion from the Specialist within 30 days of the medical examination. The written opinion shall contain the following:

- The date of the examination;
- Any recommended limitations on the employee's use of respirators; and
- If the employee provides written authorization, the written opinion shall also contain any recommended limitations on the employee's exposure to Respirable Crystalline Silica.

Hazard Communication

Beeler Construction will include Respirable Crystalline Silica in the Beeler Construction Safety and Health Manual Hazard Communication Program established to comply with the OSHA Hazard Communication Standard (29 CFR 1910.1200).

Beeler Construction will ensure that each employee has access to labels on containers of Crystalline Silica and those containers respective Safety Data Sheets (SDS's).

 Partnerships Built on Trust	4D. Silica Program	Page 17
	Revision Date: 1/8/2024	Updated
SAFETY & HEALTH MANUAL		

All employees will be trained in accordance with the provisions of the OSHA Hazard Communication Standard and the Training Section of this program. This training will cover concerns relating to cancer, lung effects, immune system effects, and kidney effects.

Beeler Construction will ensure that each employee with the potential to be exposed at or above the Action Level for Respirable Crystalline Silica can demonstrate knowledge and understanding of at least the following:

- The health hazards associated with exposure to Respirable Crystalline Silica;
- Specific tasks in the workplace that could result in exposure to Respirable Crystalline Silica;
- Specific measures Beeler Construction has implemented to protect employees from exposure to Respirable Crystalline Silica, including engineering controls, work practices, and respirators to be used;
- The contents of the OSHA Respirable Crystalline Silica Construction Standard;
- The identity of the Competent Person designated by Beeler Construction; and
- The purpose and a description of Beeler Construction's Medical Surveillance Program.

Beeler Construction will make a copy of the OSHA Respirable Crystalline Silica Construction Standard readily available without cost to any employee who requests it.

Recordkeeping

Beeler Construction will make and maintain an accurate record of all exposure measurements taken to assess employee exposure to Respirable Crystalline Silica. This record will include at least the following information:

- The date of measurement for each sample taken;
- The task monitored;
- Sampling and analytical methods used;
- Number, duration, and results of samples taken;
- Identity of the laboratory that performed the analysis;
- Type of personal protective equipment (PPE), such as respirators, worn by the employees monitored; and
- Name, social security number, and job classification of all employees represented by the monitoring, indicating which employees were actually monitored.

 Partnerships Built on Trust	4D. Silica Program	Page 18
	Revision Date: 1/8/2024	Updated
SAFETY & HEALTH MANUAL		

Beeler Construction will ensure that exposure records are maintained and made available in accordance with 29 CFR 1910.1020. Exposure records will be kept for at least 30 years.

The employer shall make and maintain an accurate record of all objective data relied upon to comply with the requirements of the OSHA Respirable Crystalline Silica Construction Standard. This record shall include at least the following information:

- The Crystalline Silica-containing material in question;
- The source of the objective data;
- The testing protocol and results of testing;
- A description of the process, task, or activity on which the objective data were based; and
- Other data relevant to the process, task, activity, material, or exposures on which the objective data were based.

Beeler Construction will ensure that objective data are maintained and made available in accordance with 29 CFR 1910.1020. Objective data records will be kept for at least 30 years.

Beeler Construction will make and maintain an accurate record for each employee enrolled in the Medical Surveillance portion of this program. The record shall include the following information about the employee:

- Name and social security number;
- A copy of the PLHCPs' and/or Specialists' written medical opinions; and
- A copy of the information provided to the PLHCPs and Specialists.

Beeler Construction will ensure that medical records are maintained and made available in accordance with 29 CFR 1910.1020. Medical records will be kept under lock and key for at least the duration of employment plus 30 years. It is necessary to keep these records for extended periods because Silica-related diseases such as cancer often cannot be detected until several decades after exposure. However, if an employee works for an employer for less than one year, the employer does not have to keep the medical records after employment ends, as long as the employer gives those records to the employee.

Program Evaluation

This program will be reviewed and evaluated on an annual basis by the Safety Department unless changes to operations, the OSHA Respirable Crystalline Silica Construction Standard (29 CFR 1926.1153), or another applicable OSHA Standard require an immediate re-validation of this program.

 Partnerships Built on Trust	4D. Silica Program	Page 19
	Revision Date: 1/8/2024	Updated
SAFETY & HEALTH MANUAL		

Will You Generate Silica Dust Containing Silica on the Job?

Below is a list of materials that contain silica, this list is to must be referenced at the beginning of each day to determine if work tasks will involve and or generate silica dust. Any material that contains silica that will be disturbed must be documented (logbook, silica checklist form-located in form section of manual) how the dust was contained/minimized (also known as Engineering Controls) must also be noted in the log books.

Materials:

- Asphalt
- Brick
- Cement and Concrete
- Concrete Blocks
- Plaster
- Fiber Cement Products
- Glass, fiberglass insulation
- Grout, Thinsets & Mudbeds
- Gunite/Shotcrete
- Mortar
- Silica Containing Paints
- Plaster
- Refractory Mortars and Castables
- Refractory Masonry Units
- Rocks
- Sand
- Soils
- Stone (granite, limestone, quartzite, sandstone, shale, slate, cultured stone, etc.)
- Stucco/EIFS
- Terrazzo
- Tile (clay, ceramic, porcelain)

Work Activities That Would Create or Disperse Silica Dust:

- Grinding, Sanding or Scraping
- Sawing or Cutting
- Drilling or Coring
- Hammering or Demolishing
- Sweeping
- Any task that would disturb the materials and create dust

If you have any questions regarding materials you may be working with or may be disturbing please contact the Beeler Safety team and or your project manager. Always assess materials and methods prior to working with these materials. Also consider that silica containing materials are commonly used as substrates and fillers underneath or hidden behind other finish materials such as flooring, wall panels, millwork, ceiling panels, etc.

 Partnerships Built on Trust SAFETY & HEALTH MANUAL	4E. Hazard Communication Program	Page 1
	Revision Date: 1/8/2024	Updated

Hazard Communication Program

PURPOSE: To provide a safe and healthful workplace for all Beeler Construction employees and to ensure that the hazards of all chemicals used or handled are communicated to employees and others that may be exposed either through routine handling or as a result of a foreseeable emergency. This communication shall be accomplished through container labeling, safety data sheets and appropriate information and training programs. This policy fulfills the requirement of a written hazard communication plan under OSHA 1910.1200 as directed by OSHA Construction standard 1926.59.

POLICY: Beeler Construction maintains a safe and healthful workplace and will ensure that employees receive training in chemical exposure recognition, training in the physical and health hazards of the chemicals in the work area, measures that employees can take to protect themselves from chemical hazards and training in locating and obtaining safety data sheets for all hazardous chemicals at each location.

TRAINING: All Beeler Construction employees shall receive initial training and periodic refreshers in Hazard Communications/SDS training.

Beeler's primary form for Hazard Communication is the use of the SDS available 24 hours a day 7 days a week 365 days a year (phone number 800-451-8346). This ensures all employees have access to SDS via phone as well as to assist any emergency personnel in the event of an emergency with necessary information. Additionally, a list of possible materials that are common to our construction sites is included at the end of this section. This list is shared with all Beeler Construction employees.

Scope and Application

Hazard communication (sometimes known as HAZCOM) informs employees of hazardous materials in the workplace. The hazardous properties of the chemicals are communicated with container labels, Safety Data Sheets and employee training. The Hazard Communication Plan provides detailed safety guidelines and instructions for the receipt, use and storage of chemicals at our facilities by employees and contractors.

The Hazard Communication Written Plan outlines:

- Responsible individuals
- Training requirements
- Contractor requirements
- Non-routine tasks
- Container labeling

 Partnerships Built on Trust SAFETY & HEALTH MANUAL	4E. Hazard Communication Program	Page 2
	Revision Date: 1/8/2024	Updated

- Safety Data Sheets (SDSs)

 SAFETY & HEALTH MANUAL	Partnerships Built on Trust	4E. Hazard Communication Program	Page 3
		Revision Date: 1/8/2024	Updated

Implementation

It is the responsibility of the Safety Director to administer this policy. It is the responsibility of any employee or subcontractor involved to adhere fully to this policy. Individual responsibilities for implementing this plan are indicated below.

Management and Safety Director

- A. Ensure compliance with this program
- B. Conduct immediate corrective action for deficiencies found in the program
- C. Maintain an effective hazard communication training program
- D. Make this plan available to employees or their designated representative
- E. Monitor the effectiveness of the program
- F. Conduct an annual audit of the program
- G. Monitor employee training to ensure its effectiveness
- H. Stays current with SDS service provided 24hrs a day 7 days a week 365 days per year

Foreman and Superintendents

- A. Ensure that all received containers are properly labeled and that labels are not removed or defaced
- B. Ensure that all shipped containers are properly labeled
- C. Ensure that department employees are properly trained in spill response
- D. Ensure that received Safety Data Sheets (SDSs) are properly distributed
- E. Obtain from the supplier/manufacturer SDSs for all chemicals purchased from retail sources. If the information is not available contact Safety director and/or SDS at **800.451.8346**

Employees

- A. Comply with the requirements of this program
- B. Report any problems with the storage or use of chemicals
- C. Immediately report spills or suspected spills of chemicals
- D. Use only those chemicals for which they have been trained
- E. Use chemicals only for specific assigned tasks in the proper manner

Subcontractors

- A. Comply with all aspects of this program
- B. Coordinate information with Beeler site Superintendent and/or Project Manager
- C. Ensure that contractor employees are properly trained
- D. Monitor and ensure proper storage and use of chemicals by subcontractor employees

 Partnerships Built on Trust SAFETY & HEALTH MANUAL	4E. Hazard Communication Program	Page 4
	Revision Date: 1/8/2024	Updated

Procedure

General Program Information

- A. This written Hazard Communication Plan consists of the following elements:
1. General Information
 2. Chemical Storage
 3. Employee Training
 4. Non-Routine Tasks
 5. Container Labels
 6. Safety Data Sheets (SDSs)
 7. Subcontractors

Chemical Storage

- A. Chemicals will be identified by the product identifier on the SDS and the product label
- B. Chemicals will be stored properly in correct containers and designated storage areas

Employee Training

- A. Initial orientation training:
1. All new employees shall receive safety orientation training by management, covering the elements of the Hazard Communication Program and the Right-to-Know Program
 2. This training will consist of general training, covering:
 - a) The location and availability of the written Hazard Communication Program
 - b) The methods and observation techniques used to detect the presence or release of a hazardous chemical in the workplace
 - c) The specific physical and health hazards of all chemicals in the workplace as outlined in the Globally Harmonized System of Classifying and Labeling Chemicals (GHS)
 - The hazard classification system outlines the following hazards that must be identified:
 - o Physical
 - o Health
 - o Pyrophoric
 - o Combustible dust
 - o Asphyxiants
 - o Hazards not otherwise classified (HNOC)
 - For each hazard classification, the specific hazard category is also determined based on the severity of the hazard and relevant scientific data
 - d) Specific control measures for protection from physical and/or health hazards
 - e) An explanation of the chemical labeling system

 Partnerships Built on Trust SAFETY & HEALTH MANUAL	4E. Hazard Communication Program	Page 5
	Revision Date: 1/8/2024	Updated

- f) The location and use of SDSs (800.451.8346)
- B. Job-specific training
 - 1. Employees will receive on-the-job training from their supervisor and/or the Location Safety Representative
 - 2. Training will include:
 - a) Health and physical hazards
 - b) Container labels
 - c) SDSs
 - d) Control methods
 - e) Proper personal protective equipment (PPE)
 - f) Proper handling of each chemical
 - g) How to detect the presence or release of chemicals
 - h) Emergency procedures, including spill clean-up and accidents
- C. Refresher training
 - 1. Hazard communication refresher training will be conducted as part of continuing safety training
- D. Immediate, on-the-spot training
 - 1. This training will be conducted by supervisors and/or the Location Safety Representative when:
 - a) A new chemical hazard is introduced
 - b) Any employee requests additional information or exhibits a lack of understanding of the safety requirements

Non-Routine Tasks

- A. Non-routine tasks are defined as:
 - 1. Working on, near or with unlabeled piping
 - 2. Working with unlabeled containers of an unknown substance
 - 3. Confined space entry where a hazardous substance may be present
 - 4. A one-time task using a hazardous substance differently than intended, i.e., using a solvent to remove stains from tile floors
- B. Training will be determined and directed by the Project Manager
- C. Non-routine tasks require the following steps:
 - 1. Conduct a hazard determination
 - 2. Determine precautions
 - 3. Implement specific training and documentation
 - 4. Perform the task
- D. All non-routine tasks will be evaluated by the project manager and safety director before the task commences to determine all hazards present
- E. Once the hazard determination is made, the project manager and safety director will determine the necessary exposure controls

 <p>Partnerships Built on Trust</p> <p>SAFETY & HEALTH MANUAL</p>	<p>4E. Hazard Communication Program</p>	<p>Page 6</p>
	<p>Revision Date: 1/8/2024</p>	<p>Updated</p>

Container Labels

- A. Each container will have an appropriate label prominently displayed that includes:
1. A product identifier
 2. A signal word
 3. The applicable hazard statements
 4. A pictogram
 5. Precautionary statements
 6. The contact information of the responsible party
- B. Portable containers which contain a small amount of chemicals need not be labeled if they are used immediately during that shift, but they must be under the strict control of the employee using the product
- C. All warning labels, tags, etc., must be maintained in a legible condition and not defaced
- D. Incoming chemicals are to be checked for proper labeling. The Hazard Communication Standard (HCS) will require pictograms on labels to alert users of the chemical hazards to which they may be exposed. Each pictogram consists of a symbol on a white background framed within a red border and represents a distinct hazard(s). The pictogram on the label is determined by the chemical hazard classification.



Partnerships
Built on Trust

SAFETY & HEALTH MANUAL









4E. Hazard Communication Program

Page
7

Revision Date: 1/8/2024

Updated



HCS Pictograms and Hazards

<p>Health Hazard</p>  <ul style="list-style-type: none"> • Carcinogen • Mutagenicity • Reproductive Toxicity • Respiratory Sensitizer • Target Organ Toxicity • Aspiration Toxicity 	<p>Flame</p>  <ul style="list-style-type: none"> • Flammables • Pyrophorics • Self-Heating • Emits Flammable Gas • Self-Reactives • Organic Peroxides 	<p>Exclamation Mark</p>  <ul style="list-style-type: none"> • Irritant (skin and eye) • Skin Sensitizer • Acute Toxicity (harmful) • Narcotic Effects • Respiratory Tract Irritant • Hazardous to Ozone Layer (Non-Mandatory)
<p>Gas Cylinder</p>  <ul style="list-style-type: none"> • Gases Under Pressure 	<p>Corrosion</p>  <ul style="list-style-type: none"> • Skin Corrosion/ Burns • Eye Damage • Corrosive to Metals 	<p>Exploding Bomb</p>  <ul style="list-style-type: none"> • Explosives • Self-Reactives • Organic Peroxides
<p>Flame Over Circle</p>  <ul style="list-style-type: none"> • Oxidizers 	<p>Environment Skull (Non-Mandatory)</p>  <ul style="list-style-type: none"> • Aquatic Toxicity 	<p>Skull and Crossbones</p>  <ul style="list-style-type: none"> • Acute Toxicity (fatal or toxic)

Hazard Communication Standard Labels



OSHA has updated the requirements for labeling of hazardous chemicals under its Hazard Communication Standard (HCS). As of June 1, 2015, all labels will be required to have pictograms, a signal word, hazard and precautionary statements, the product identifier, and supplier identification. A sample revised HCS label, identifying the required label elements, is shown on the right. Supplemental information can also be provided on the label as needed.

SAMPLE LABEL

<p>CODE _____</p> <p>Product Name _____</p>	}	<p>Product Identifier</p>	<p style="text-align: center;">Hazard Pictograms</p> <div style="display: flex; justify-content: space-around; align-items: center;">   </div>	
<p>Company Name _____</p> <p>Street Address _____</p> <p>City _____ State _____</p> <p>Postal Code _____ Country _____</p> <p>Emergency Phone Number _____</p>	}	<p>Supplier Identification</p>	<p style="text-align: center;">Signal Word</p> <p style="text-align: center;">Danger</p>	
<p>Keep container tightly closed. Store in a cool, well-ventilated place that is locked.</p> <p>Keep away from heat/sparks/open flame. No smoking.</p> <p>Only use non-sparking tools.</p> <p>Use explosion-proof electrical equipment.</p> <p>Take precautionary measures against static discharge.</p> <p>Ground and bond container and receiving equipment.</p> <p>Do not breathe vapors.</p> <p>Wear protective gloves.</p> <p>Do not eat, drink or smoke when using this product.</p> <p>Wash hands thoroughly after handling.</p> <p>Dispose of in accordance with local, regional, national, international regulations as specified.</p> <p>In Case of Fire: use dry chemical (BC) or Carbon Dioxide (CO₂) fire extinguisher to extinguish.</p> <p>First Aid If exposed call Poison Center. If on skin (or hair): Take off immediately any contaminated clothing. Rinse skin with water.</p>		}	<p>Precautionary Statements</p>	<p>Hazard Statements</p> <p>Highly flammable liquid and vapor. May cause liver and kidney damage.</p>
			<p style="text-align: center;">Supplemental Information</p> <p>Directions for Use</p> <p>_____</p> <p>_____</p> <p>_____</p> <p>Fill weight: _____ Lot Number: _____</p> <p>Gross weight: _____ Fill Date: _____</p> <p>Expiration Date: _____</p>	

 Partnerships Built on Trust SAFETY & HEALTH MANUAL	4E. Hazard Communication Program	Page 9
	Revision Date: 1/8/2024	Updated

Comparison of NFPA 704 and HazCom 2012 Labels

	 NFPA 704	 HazCom 2012
Purpose	Provides basic information for emergency personnel responding to a fire or spill and those planning for emergency response.	Informs workers about the hazards of chemicals in workplace under normal conditions of use and foreseeable emergencies.
Number System: NFPA Rating and OSHA's Classification System	0-4 0-least hazardous 4-most hazardous	1-4 1-most severe hazard 4-least severe hazard • The Hazard category numbers are NOT required to be on labels but are required on SDSs in Section 2. • Numbers are used to CLASSIFY hazards to determine what label information is required.
Information Provided on Label	<ul style="list-style-type: none"> • Health-Blue • Flammability-Red • Instability-Yellow • Special Hazards*-White * OX Oxidizers W Water Reactives SA Simple Asphyxiants	<ul style="list-style-type: none"> • Product Identifier • Signal Word • Hazard Statement(s) • Pictogram(s) • Precautionary statement(s); and • Name address and phone number of responsible party.
Health Hazards on Label	Acute (short term) health hazards ONLY. Acute hazards are more typical for emergency response applications. Chronic health effects are not covered by NFPA 704.	Acute (short term) and chronic (long term) health hazards. Both acute and chronic health effects are relevant for employees working with chemicals day after day. Health hazards include acute hazards such as eye irritants, simple asphyxiants and skin corrosives as well as chronic hazards such as carcinogens.
Flammability/Physical Hazards on Label	NFPA divides flammability and instability hazards into two separate numbers on the label. Flammability in red section Instability in yellow section	A broad range of physical hazard classes are listed on the label including explosives, flammables, oxidizers, reactives, pyrophorics, combustible dusts and corrosives.

 Partnerships Built on Trust SAFETY & HEALTH MANUAL	4E. Hazard Communication Program	Page 10
	Revision Date: 1/8/2024	Updated

Where to get information to place on label	Rating system found in NFPA Fire Protection Guide to Hazardous Materials OR NFPA 704 Standard System for Identification of the Hazards of Materials for Emergency Response 2012 Edition. Tables 5.2, 6.2, 7.2 and Chapter 8 of NFPA 704	OSHA Hazard Communication Standard 29 CFR 1910.1200 (2012). 1) Classify using Appendix A (Health Hazards) and Appendix B (Physical Hazards) 2) Label using Appendix C
Other	The hazard category numbers found in section 2 of the HC2012 compliant SDSs are NOT to be used to fill in the NFPA 704 diamond.	Supplemental information may also appear on the label such as any hazards not otherwise classified, and directions for use.
Website	www.nfpa.org/704	www.osha.gov OR www.osha.gov/dsg/hazcom/index.html



Partnerships
Built on Trust

SAFETY & HEALTH MANUAL

4E. Hazard Communication Program

Page
11

Revision Date: 1/8/2024

Updated

Wallet Cards



Hazard Communication

Workers have the right to *know* and *understand* the hazardous chemicals they use and how to work with them safely.

www.osha.gov/hazcom 800-321-OSHA (6742) TTY 1-877-889-5627



Workers must be trained to understand these pictograms and the hazards they represent. To learn more about training, labeling, and safety data sheet requirements, scan the QR code.



 Partnerships Built on Trust SAFETY & HEALTH MANUAL	4E. Hazard Communication Program	Page 12
	Revision Date: 1/8/2024	Updated

SDS Information

- A. SDSs are supplied by the chemical manufacturer to provide additional information concerning the safe use of the product
- B. SDSs must have a unique product identifier that corresponds to the product label
- C. SDSs must be in English; however, other languages are allowed in addition to an English version
- D. SDS information is accessible to all employees on all shifts at **800-451-8346**
- E. Prior to beginning work with a chemical, employees must be trained on its SDS
- F. Each SDS provides these sixteen sections in the following order:
 - 1. Section 1. Identification
 - 2. Section 2. Hazard identification
 - 3. Section 3. Composition information on ingredients
 - 4. Section 4. First aid measures
 - 5. Section 5. Fire-fighting measures
 - 6. Section 6. Accidental release measures
 - 7. Section 7. Handling and storage
 - 8. Section 8. Exposure controls/personal protection
 - 9. Section 9. Physical and chemical properties
 - 10. Section 10. Stability and reactivity
 - 11. Section 11. Toxicological information
 - 12. Section 12. Ecological information
 - 13. Section 13. Disposal considerations
 - 14. Section 14. Transport information
 - 15. Section 15. Regulatory information
 - 16. Section 16. Other information

Subcontractors

- A. All subcontractors working on Beeler projects are required to follow the requirements of this program
- B. Manage the SDSs
 - 1. Obtain SDSs for all chemicals before they are used
 - 2. Review each SDS when it is received to evaluate whether the information is complete and to determine if our existing protective measures are adequate
 - 3. SDSs are required for all hazardous materials used on site by project personnel
- C. Labels
 - 1. Ensure that all received containers are properly labeled and that labels are not removed or defaced

 Partnerships Built on Trust SAFETY & HEALTH MANUAL	4E. Hazard Communication Program	Page 13
	Revision Date: 1/8/2024	Updated

The following is list of possible materials that are most common to our construction sites; not all these materials will be on site at any given time. SDSs are immediately available for these 24 hours a day, 7 days a week, 365 days a year via phone at 800-451-8346.

SDS LIST

ADHESIVES

Construction Glues

- Titebone Interior/Exterior Construction Adhesive
- Beats The Nail VOC Construction Adhesive
- Beats The Nail Drywall Construction Adhesive
- DAP 2000 Heavy Duty Construction Adhesive
- Super Hybond
- Super Hybond 60 Plus, 70 Plus & 80 Plus
- IPS Weld-On

Carpenters/Wood Glues

- Elmer's Carpenters Wood Glue
- Elmer's Probond Wood Glue
- Elmer's Carpenters Exterior Wood Glue
- Titebond All Purpose White Glue
- Titebond Original Wood Glue
- Titebond II Premium Wood Glue
- Titebond II Extend
- Titebond II Dark Wood Glue
- Titebond III Ultimate Wood Glue
- Gorilla Wood Glue
- Mastercraft Carpenters Wood Glue
- Super Glue Carpenters Wood Glue

Plastic Laminate Glues/Adhesives

- Wilsonart H20 Adhesive
- Wilsonart 400 Contact Adhesive
- Wilsonart 500 Adhesive
- Wilsonart 800/801 Contact Adhesive
- Wilsonart 880/881 Contact Adhesive
- Wilsonart 900 Series Adhesive
- Wilsonart 3100 Adhesive Series
- Formica 100 Brushable Contact Adhesive
- Formica F140 Adhesive
- Lokweld 3000 Series Adhesive
- Lokweld 500 Adhesive
- Lokweld 600 Adhesive

 <p>Partnerships Built on Trust</p> <p>SAFETY & HEALTH MANUAL</p>	<p>4E. Hazard Communication Program</p>	<p>Page 14</p>
	<p>Revision Date: 1/8/2024</p>	<p>Updated</p>

- Lokweld 800/881 Contact Adhesive

 Partnerships Built on Trust SAFETY & HEALTH MANUAL	4E. Hazard Communication Program	Page 15
	Revision Date: 1/8/2024	Updated

Flooring Adhesives

- Dap Weldwood Multipurpose Floor Covering Adhesive\
- Weldwood Floor Covering Adhesive
- DAP 4000 Subfloor & Deck Construction Adhesive
- Robert's 3200 Max Performance M/P Carpet and Sheet Vinyl Adhesive
- Lees Pressure Sensitive Adhesive
- Mapei Ultrabond ECO 711
- Euco Weld
- Roberts 3095 Fast Grab Carpet Adhesive
- Roberts 4015 Glue Down Carpet Seam Adhesive
- Roberts 8415 Premium Carpet Seam Adhesive
- Henry 430 "Clear Pro" Thin Spread Floor Tile Adhesive
- BTN Cove Base Construction Adhesive
- Armstrong S-725 Wall base Adhesive
- Henry 440 Cove Base Adhesive
- Ultrabond ECO 575 premium Cove Base Adhesive

Miscellaneous Adhesives

- Titebond Fast Grab FRP Adhesive
- FRP-300 Liquid Nails
- DAP Weldwood FRP Adhesive
- DAP FRP Adhesive
- Black Epoxy Contact Cement Part B
- Probond SAF-T Contact Cement
- DAP Contact Cement
- Heavy Duty Gray LO-VOC PVC Cement
- Flexible PVC Cement
- Oatey Medium Clear PVC Cement
- Ultra Plus Clear Pro 888 Wallcovering Adhesive
- Golden Harvest E-Z Hang System Wallpaper Past GH-79
- Dynamite 760 Vinyl Over Vinyl Wallcovering Adhesive
- Suregrip 127 Vinyl Over Vinyl Wallcovering Adhesive
- Spray N Glue Adhesive
- Contact Adhesive 5
- Black Contact Adhesive
- Fastbond Contact Adhesive
- Scotchgrip Contact Adhesive
- E-Z Wall Mastic
- M-D 282 Pedestal Adhesive
- Acrovyn Water Based Contact Adhesive
- Acrovyn Heavy Duty Water Based Mastic
- Acrovyn CS 2000 Rollable Water Based Mastic
- Acrovyn Water Based Mastic Primer

 Partnerships Built on Trust SAFETY & HEALTH MANUAL	4E. Hazard Communication Program	Page 16
	Revision Date: 1/8/2024	Updated

CAULKS AND SEALANTS

- Dow Corning 100% Silicone Sealant – Clear
- Dow Corning 100% Silicone Sealant – White
- Dupont Silicone Sealant All Colors for Corian
- GE Acrylic Caulk
- GE22582 Acrylic Caulk
- Red Devil/Ace Hardware 50 Year Silicone Sealant
- Polyseamseal Tub and Tile Adhesive Caulk
- Polyseamseal All Purpose Adhesive Caulk
- Sonneborn NP1 Polyurethane Sealant
- Sikaflex 1A All Colors
- DP 1010, DP 1020 Duct Sealant
- All Purpose RTV Silicone Sealant
- Red Devil Paint Master Plus 35 Year Siliconized Acrylic Caulk
- Dow Great Stuff Foam Sealant

CLEANERS

- Comet Liquid Cleaner With Bleach
- Ajax Cleanser
- Palmolive Dishwashing Liquid and Antibacterial Hand Soap
- Murphy's Oil Soap Wood Cleaner Spray-Orange
- Scott's Liquid Gold Wood Wipes
- Scott's Liquid Gold Wood Cleaner & Preservative
- Noxon 7 Metal Polish
- Carnauba Spray Wax
- #41 Glass Advantage Glass Cleaner
- Fantastik Antibacterial All Purpose Cleaner-Lemon Power
- Brillianize
- Goo Gone Pro Power Spray Gel
- Countertop Magic Aerosol
- Brasso Multi-Purpose Metal Polish
- Murphy's Oil Soap Liquid
- Old English Oil (Lemon, Orange, Red)
- DIF Gel
- DIF Fast Acting Gel
- Armstrong S-390 Floor Wax
- Mr. Clean
- Pledge – Lemon Aerosol
- Fantastik All Purpose Cleaner
- Dawn Dishwashing Soap
- Goof Off
- 3M Desk and Office Cleaner

 Partnerships Built on Trust SAFETY & HEALTH MANUAL	4E. Hazard Communication Program	Page 17
	Revision Date: 1/8/2024	Updated

- Window and Mirror Cleaner
- Windex Blue
- Windex Multi Surface Cleaner – Sparkling Orange
- Windex Powerized Formula – Ready To Use
- Clorox Liquid Plumber
- Resolve Carpet Cleaner
- Scrub Free Mildew Stain Remover
- Scrub Free Soap Scum Remover
- Scrub Free Disinfectant Bathroom Cleaner
- Turtle Wax Paste Wax
- Turtle Wax Finish 2001 Wax
- Spray Way Contact Cleaner

CONCRETE/MASONRY/GROUT

Cements

- Portland Cement – NIST Standard
- Portland Cement – Universal Inc
- Portland Cement - Empire White Products
- Cements – Quikrete
- Portland Cement Based Concrete Products – Quikrete
- Portland Cement Based Repair Materials – Quikrete
- Mortars, Stuccos, ThinSet Products, Dry Packaged Portland Cement Base Products - Quikrete
- Portland Cement - Lafarge
- Portland Cement - Buzzi Unicem
- Portland Cement Thin-set Mortar Gray - USG
- Portland Cement Thin-set Mortar White - USG
- Fiberock Latex Modified Portland Cement Patch Fast Set - USG
- Portland Cement Types I, II, & III – Continental Cement Company
- Anchoring Cement – Sierra Corp/TK Products
- Cement Board - USG

Grouts and Mortars

- HYDROXI PRO Grout Smart
- CTG Grouts Various Colors – Bostik
- Accucolor Sanded Grout
- Masterflow 928 Grout
- DL-26 Acrylic Latex Grout Additive
- NA 3000 Latex Mortar Additive

 Partnerships Built on Trust SAFETY & HEALTH MANUAL	4E. Hazard Communication Program	Page 18
	Revision Date: 1/8/2024	Updated

Miscellaneous Concrete Products

- Ardex Feather Finish
- Thorite General Purpose Concrete Restoration
- Thorocoat (Fine and Course)
- Thoropatch
- Thorogrip
- Thoro Underlayment Self Leveling
- Henry 545 Featheredge Cement Patch
- DAP Concrete Floor Leveler E/M
- Full Flex Latex ThinSet
- Polycast

Concrete Components/Add Mixtures

- Quikrete Sands and Gravels
- Natural Sand
- Vulcan Natural Sand and Gravel
- Lafarge Sand and Gravel
- Silica Sand – All Grades
- Sulfur
- Limestone
- Mason’s Lime
- Calcium Carbonate (Ground Limestone)
- Calcium Hydroxide (Hydrated Lime)
- Magnesium Mydroxide
- Kelnor HTPE – Pitch Binder
- Vocomp 20 Water Based Curing and Sealing Compound
- Acryl 60 Admixture

CONSTRUCTION MATERIALS

Woods

- Wood and Wood Products – Georgia Pacific
- Wood Dust – Boise Cascade
- Wood Dust – Plum Creek
- Fire Pro Treated Wood
- Dricon Fire Retardant Pressure Treated Wood - Koppers
- Arsenic Treated Wood – Osmose
- ACQ Pressure Treated Wood
- Pressure Treated Wood – PPG
- CCAW Extra Pressure Treated Wood – Koppers

 Partnerships Built on Trust SAFETY & HEALTH MANUAL	4E. Hazard Communication Program	Page 19
	Revision Date: 1/8/2024	Updated

Plywoods

- Plywood's and Particle Boards
- Softwood Plywood – Plum Creek
- Plywood – Weyerhaeuser
- HDO Concrete Form Overlay Plywood – Plum Creek
- MDO Concrete Form Overlay Plywood – Plum Creek
- Softwood Plywood With Oil Coating for Concrete Forms – Plum Creek
- Sign Grade Medium Density Overlay Plywood – Plum Creek
- Marine Deck – Plum Creek
- Masonite
- Micore Boards - USG

MDF's

- Medium Density Fiberboard (MDF) – Plum Creek
- Medium Density Fiberboard (MDF) – Flakeboard Company
- Medium/High Density Fiberboard – Plum Creek
- Glacier Green High Density Fiberboard – Plum Creek
- Ultra Core High Density Fiberboard – Plum Creek
- Glacier Clear Fiberboard – Plum Creek
- Particle Board – Flakeboard Company

Plastic Laminates and Solids Surfaces

- Pionite Plastic Laminates
- Formica Plastic Laminates
- Formica Plastic Laminates – Metallic Products
- Wilsonart Plastic Laminates
- Nevamar Plastic Laminates
- Corian Solid Surface Material
- Corian Joint Adhesive
- Corian Joint Adhesive Kit – Component A
- Corian Joint Adhesive Kit – Component B
- Corian Silicone Sealants (all colors)
- Formica Brand “Fountainhead” Solid Surface

Metals

- Carbon and Alloy Steels
- Aluminum
- Anodized Aluminum
- Brass
- Copper
- Zinc
- Bimetal saw blades

 Partnerships Built on Trust SAFETY & HEALTH MANUAL	4E. Hazard Communication Program	Page 20
	Revision Date: 1/8/2024	Updated

Plastics/PVC's Fiberglass

- Lucite Acrylic Sheet
- Polypropylene Film (plastic sheeting) – Exxon Mobile
- Polypropylene Sheet (plastic sheeting) - Pacur
- Polyethylene Film (plastic sheeting)
- PVC Pipe
- Rigid PVC
- FRP Panels – Interplastic Corporation
- FRP – Crane Composites
- Fiber Glass Mat – Johns Manville

Miscellaneous

- Unleaded Gasoline
- Diesel Fuel
- Arctic Ban Antifreeze for Marine Water Systems
- Kingsford Charcoal Lighter Fluid

DRYWALL/PLASTER/STUCCO/JOINT COMPOUNDS/ ETC.

Gypsum Board/Backer Board

- Gypsum Wall Board Panels
- Fireguard Gypsum Boards
- Soundbreak Gypsum Board
- Paper Faced Gypsum Boards
- Glass Mat Faced Gypsum Panels
- DensShield Backer Board
- ProRoc Backer Board
- ProRoc Gypsum Board Products
- DUROCK Exterior Cement Board
- HardiBoard

Joint Compounds

- Sheetrock All Purpose Joint Compound
- Sheetrock All Purpose Joint Compound Ready Mixed
- Sheetrock Lightweight All Purpose Joint Compound A/P Lite
- Sheetrock Lightweight All Purpose Joint Compound Plus 3 Ready Mixed
- Sheetrock Redi-Mix Joint Compound Ready Mixed
- Sheetrock Lightweight All Purpose Joint Compound Ready Mixed Plus 3 with Dust Control
- Sheetrock Extra Lightweight All Purpose Joint Compound XLW
- Sheetrock Topping I Joint Compound Ready Mixed
- Sheetrock Topping Joint Compound
- Sheetrock Easy Sand 30
- Sheetrock Easy Sand 45
- Sheetrock Easy Sand 90



Partnerships
Built on Trust

SAFETY & HEALTH MANUAL

4E. Hazard Communication Program

Page
21

Revision Date: 1/8/2024

Updated

- Sheetrock Durabond 20
- Sheetrock Durabond 25
- Sheetrock Durabond 45
- Sheetrock Durabond 90
- Sheetrock Durabond 210
- Sheetrock Durabond 300
- National Gypsum Company Ready Mix Joint Compounds
- Lafarge Ready Mix Joint Compounds

Tapes

- Sheetrock Joint Tape
- Durock Exterior Tape
- Durock Interior Type P Tape (Fiberglass)
- Imperial Tape Type S (Fiberglass)
- Beadex Drywall Joint Tape

Plaster

- Structo-Lite Premixed Gypsum Plaster
- Red Top Gypsum Plaster
- Red Top Gypsum Plaster LW Formula
- Sheetrock Plaster of Paris
- Georgia Pacific Plasters
- Quikrete Plasters and Coatings
- USG CGC Plaster of Paris

Stucco

- CKS Stucco
- Ultra Kote One Coat Stucco
- Quikrete Cements for Masonry and Stucco
- Quikrete Acrylic Stucco and Crack Repair

Admixtures

- Plaster Bonder
- USG Gypsum Plaster Accelerator – High Strength
- USG Gypsum Plaster Accelerator – Regular Strength
- USG Accelerator “E”
- USG Retarder Premix
- USG Plaster Retarder High Strength
- Tri-Bond Agent – TK Tribond

 Partnerships Built on Trust SAFETY & HEALTH MANUAL	4E. Hazard Communication Program	Page 22
	Revision Date: 1/8/2024	Updated

Miscellaneous

- Red Devil Onetime Lightweight Spackling Compound
- Red Devil Vinyl Spackling Compound
- Ace Hardware Vinyl Spackling Compound
- THIN PATCH
- Sheetrock Ceiling Spray Textures
- Sheetrock Ceiling Spray Texture QT Fine Perlite
- Sheetrock Ceiling Spray texture QT Poly/Perlite Medium
- Skimcoat Underlayment

FIRESTOPPING

Firestopping

- USG Thermafiber SmokeSeal
- Cementitious Fireproofing
- Hilti CP 136 Fire Blocker
- Hilti 601S Elastomeric Firestop Sealant
- Hilti CP 604 Self Leveling Firestop Sealant
- Hilti CP 606 Flexible Firestop Sealant
- Hilti CP 617, 618 & 619 Firestop Pad, Putty Stick and Putty Roll
- Hilti CP 620 Fire Foam
- Hilti CP 637 Firestop Mortar
- Hilti 643 & 644 Firestop Collars
- Hilti 648-S & 648-E Firestop Wrap Strip
- Hilti FS 657 Fire Block, CP 658T Firestop Plug
- Hilti CP 672 Speed Spray
- Hilti CP 675 T Firestop Board
- Hilti CP 680-P & CP 680-M Cast-In Firestop Devices
- Hilti CP 681 Tub Box Kit
- Hilti CP 767 Speed Strips
- Hilti CP 677 Speed Plugs
- Hilti FS-ONE High Performance Intumescent Firestop Sealant
- Hilti Mineral Wool

 Partnerships Built on Trust SAFETY & HEALTH MANUAL	4E. Hazard Communication Program	Page 23
	Revision Date: 1/8/2024	Updated

INSULATION

Fiberglass/Wool

- Owens Corning – Duraflex, Aeroflex Insulation (uncoated)
- Owens Corning – High Temperature Fiber Glass Insulation
- Owens Corning – Loose Fill Insulation
- Owens Corning – Fiber Glass Wool
- Owens Corning – Pink Plus Fiberglass Insulation (R-13)
- Johns Manville – Multipurpose Fiberglass Insulation
- USG – Slag Wool, Mineral Wool
- Western Fiberglass – Foil Faced Fiberglass Insulation
- Thermafiber – Thermafiber Slag Wool Insulation
- ROXUL – Mineral Wool Insulation

Rigid/Styrofoam

- Dow – Extruded Styrofoam Insulation
- Dow – SUPER TUFF 1 ½” Insulation Sheathing
- Dow – SUPER TUFF 1” Cavity Wall Insulation Sheathing
- Dow – SUPER TUFF 1” Insulation Sheathing
- Dow – SUPER TUFF ¾” Insulation Sheathing
- Owens Corning – Extruded Polystyrene Insulation
- Owens Corning – Low Density Fiber Glass Insulation Board (unfaced)
- Owens Corning – Low Density Fiber Glass Insulation Board (faced)

MISCELLANEOUS MATERIALS

Lubricants

- Liquid Wrench
- Fluoroglide Spray
- Marvel Air Tool Oil
- WD 40
- Lithium Grease
- Simple Green Cleaner/Degreaser

Automotive/Engines

- RV Antifreeze
- Prestone Antifreeze
- Automatic Transmission Fluid
- Brake Fluid
- 2-Cycle Engine Oil

Fuels

- Unleaded Gasoline
- Diesel Fuel
- Kerosene
- Propane
- Charcoal Lighter Fluid

 <p>Partnerships Built on Trust</p> <p>SAFETY & HEALTH MANUAL</p>	<p>4E. Hazard Communication Program</p>	<p>Page 24</p>
	<p>Revision Date: 1/8/2024</p>	<p>Updated</p>

Waterproofing

- Thompson's Multi Surface Clear Water Seal
- Thompson's Professional Waterproof Water Seal
- Behr Concrete and Masonry Waterproof
- Thoroseal (all colors)
- Solvent Damp Proofing
- Damp Proofing
- Bright Kure and Seal

Roofing

- Slag, Coal Tar
- Tarred Roofing Felt
- Johns Manville Roofing Asphalt
- Glass Fiber Roofing Felt

Miscellaneous Products

- Oil Based Sweeping Compound
- Spectracide Wasp and Hornet Killer
- Hydrochloric Acid
- OATEY PVC Cement
- OATEY PVC Cleaner
- OATEY PVC Purple Primer
- Premium Buffing Compound
- Celotex Acoustical Ceiling
- N/C No Charge Static Dissipative Floor Finish
- Water Based Seamseal
- Soundstop Board

PAINTS AND PRIMERS

Paints

- True Value EZ-Kare Latex Interior Semi Glass Enamel
- Glidden Ultrahide Rust Preventative Int/Ext Alkyd Semi-Gloss
- Glidden Ultrabuild Int Semi-Gloss
- Behr Premium Plus Int/Ext Porch and Floor Paint
- The Nelson Paint Co. Porch and Floor Paint
- Sherwin Williams Int Latex White
- Sherwin Williams Ext Flat Latex White
- Sherwin Williams Ext Gloss Latex Tinting White
- Sherwin Williams Ext Satin Latex
- Sherwin Williams Int Flat Latex
- Sherwin Williams ProPlasterCoat™ 100% Acrylic Int Latex Eg-Shel for Plaster Finishes
- Pratt & Lambert Red Real Int Latex Satin (Aqua Satin), Designer White*/Base
- Benjamin Moore Ironclad Latex Low Luster Metal and Wood Enamel

 Partnerships Built on Trust SAFETY & HEALTH MANUAL	4E. Hazard Communication Program	Page 25
	Revision Date: 1/8/2024	Updated

- Benjamin Moore Impervex Latex High Gloss Metal and Wood Enamel
- Benjamin Moore Moorespec Int Acrylic Latex Eggshell
- ICI Dulux Ultra Eggshell Acrylic Wall and Trim Enamel
- ICI Dulux Latex Semi-Gloss Int Wall and Trim Enamel
- PPG Speedhide Int Latex Flat White/Pastel
- PPG Latex Enamel White
- PPG Pitt Bull Athletic White

Primers/Sealers

- True Value EZ-Kare Oil Int Primer/Sealer
- Dutch Boy Int Oil Enamel Primer/Sealer White
- ACE Premium Enamel Primer, White Wood
- General Paint Corp 28-080 Tradesmen Latex Sealer
- Behr 434 PP Ext Primer/Undercoater
- Sherwin Williams Preprite Drywall Conditioner
- ICI Prep and Prime Acrylic Gripper All Purpose Stain Killer
- PPG Pitt Bull Primer
- Chemrex Primer 800

Aerosol Paints

- Rust-Oleum White Spray Paint, V2392
- Rust-Oleum American Accents Classic – All Colors
- Rust-Oleum American Accents Heritage – All Colors
- Rust-Oleum American Accents Country – All Colors
- Rust-Oleum Painters Touch Aerosol Top Coats- All Colors
- Rust-Oleum White Marking Spray Paint
- Rust-Oleum Water based Inverted Marking Paint – All Colors
- Rust-Oleum Safety Red Spray Paint
- Rust-Oleum Alert Orange Spray Paint
- Krylon Decorator Spray Paints, Acrylic Crystal Clear
- Krylon Indoor Outdoor Latex Paint, Fluorescent Orange

Aerosol Primers

- Rust-Oleum Stops Rust Clean Primer Aerosol
- Rust-Oleum Flat Gray Primer
- Rust-Oleum Professional HP Enamel Primer Aerosol

Miscellaneous Paints and Coatings

- Bondex D-Y-I Rough Texture Paint
- Sheetrock Sand Finish Paint Additive
- Acoustical Ceiling Tile Restorer
- PPG Natural Wood Finish Green 600 VOC

 Partnerships Built on Trust SAFETY & HEALTH MANUAL	4E. Hazard Communication Program	Page 26
	Revision Date: 1/8/2024	Updated

POLYURETHANES/VARNISHES/LACQUERS/STAINS

Polyurethanes

- Brush Grade Polyurethane, Stainless Steel Coatings Inc
- Heavy Duty Polyurethane Varnish, Sherwin Williams
- Clear Polyurethane Glass/Satin, Hydrocote Co.
- Clear Polyurethane Satin Finish, McCormick Paints
- Stays Clear Acrylic Polyurethane High Gloss, Benjamin Moore
- Minwax Fast Drying Polyurethane Clear Gloss
- Minwax Super Fast Drying Polyurethane Satin
- Minwax Polyshades Interior Stain & Polyurethane Glass Finish Golden Oak
- Minwax Polyshades Interior Stain & Polyurethane Glass Finish Honey Pine

Varnishes

- Bulls Eye Spar Varnish Semi-Gloss
- Bulls Eye Spar Varnish Gloss
- Acrylic Latex Varnish, Pratt and Lambert
- Marine Spar Varnish Clear Gloss, INSL-X Products
- Ultra Clear CONV Varnish Sealer
- Sprayon Clear Insulating Varnish, Sherwin Williams

Lacquers

- Minwax Clear Brushing Lacquer, Clear Gloss
- Opex Clear Lacquers, Sherwin Williams
- Minwax Clear Lacquer Sanding Sealer

Stains

- Minwax Wood Finish Aerosol Golden Pecan
- Minwax Wood Finish Jacobean
- Minwax Wood Finish Fruitwood

Miscellaneous

- Crown Spray Tool – Aerosol

SOLVENTS

Solvents

- Wilsonart 110 Adhesive Solvent
- Lokweld 100 Flammable Solvent
- Locweld 110 Adhesive Solvent
- Formica Contact Adhesive Solvent
- Formica 200
- VOCOMP 20
- Sunnyside Do It Mineral Spirits/Paint Thinner
- Sunnyside Pringles Odorless Mineral Spirits
- Sunnyside Odorless Mineral Spirits
- Sunnyside Paint Thinner
- Sunnyside Pro Solutions Paint Thinner



Partnerships
Built on Trust

SAFETY & HEALTH MANUAL

4E. Hazard Communication Program

Page
27

Revision Date: 1/8/2024

Updated

- Zinsser Parks Mineral Spirits
- Sherwin Williams Mineral Spirits
- Ashland Odorless Mineral Spirits
- W.M. Barr Odorless Mineral Spirits
- Sunnyside 457 Lacquer Thinner
- W.M Barr Ace Lacquer Thinner
- Sunnyside True Value Lacquer Thinner
- Sunnyside Lacquer Thinner
- Sherwin Williams Lacquer Thinner
- Acetone
- Sigma Aldrich Acetone
- Sunnyside Acetone
- Acetone/Ether
- Sunnyside Naptha
- Sherwin Williams VM & P Naptha
- PPG High Flash Naptha
- Napthalene
- Methyl Alcohol
- Denatured Alcohol
- Isopropyl Alcohol
- Hydrochloric Acid
- Acrylonitrile
- Zip Strip
- Zip Strip Original Scent
- Graffiti & Spray Paint Remover
- Liquid Paint Remover
- Paint Remover
- Back To Nature Paint Remover
- Klean Strip, Citri Strip
- HYBOND Reducer Cleaner

 <p>Partnerships Built on Trust</p> <p>SAFETY & HEALTH MANUAL</p>	<p>4E. Hazard Communication Program</p>	<p>Page 28</p>
	<p>Revision Date: 1/8/2024</p>	<p>Updated</p>

WOOD FILLERS

Wood Fillers

- Bondo Red Cream Hardener
- Bondo Lightweight Body Filler
- Bondo Resin Repair Kit
- Dap Wood Patch - All Colors
- Dap Latex Wood Patch – All Colors
- MINWAX Stainable Wood Filler
- MINWAX Wood Putty
- DAP Latex Wood Patch – All Colors
- DAP Bondex Wood Patch
- ZAR Wood Patch – Neutral and Red Oak
- Elmer’s Int/Ext Carpenter’s Wood Filler
- Elmer’s E855 Interior Wood Filler – All Colors
- Elmer’s Professional Wood Filler

 Partnerships Built on Trust SAFETY & HEALTH MANUAL	4F. Lead Program	Page 1
	Revision Date: 1/8/2024	Updated

Lead Awareness Program

PURPOSE: To provide a safe and healthful workplace for all Beeler Construction employees and to ensure that the hazards of lead are communicated to employees and others that may be exposed either through routine handling or as a result of a foreseeable emergency. This policy fulfills the requirement of the OSHA 29 CFR 1926.62.

POLICY: Lead is not typical to Beeler's standard scope of work and therefore any lead encounter will be dealt with on a case by case basis. Under no circumstances shall any Beeler employee enter any area or handle any product containing lead without being properly trained.

TRAINING: All Beeler Construction employees encountering a task involving lead shall receive training compliant with OSHA 29 CFR 1926.62.

- PEL(1926.62 appB I para C)
 - is 50 micrograms over an 8 hour period adjusted for extended time if needed (ie 10 hr day reduces to 40 micrograms)
- Exposure Assessment (1926.62 appB II para D)
 - Action level is over 30 micrograms.
If lead is suspected to be present on a job site an initial determination will be made to determine if any employee of will be exposed to lead and exposure will be prevented. At no time will the action level be exceeded.
- Engineering and Work Practice Controls
 - In order to reduce and maintain employee exposure to lead to or below the permissible exposure limit on the job site, will cut all lead in open area. Only hand tools will be used to reduce dust exposure. No power tools will be used.
- Protective Work Clothing and Equipment
 - Appropriate protective clothing and equipment can include the following:
 - Tyvek suits
 - Gloves
 - Protective clothing is to be removed only in change areas provided for that Purpose and disposed of after use.
 - Contaminated protective clothing Tyvek suits to be disposed of will be placed in bagged containers in the change area. The bags shall be sealed shut and disposed of.
 - Caution: Clothing contaminated with lead. Do not remove dust by blowing or shaking.

HOUSEKEEPING: Vacuuming shall be used as the preferred method for maintaining all surfaces as free as practicable of lead accumulation in work areas exposed to lead or lead compounds.

 SAFETY & HEALTH MANUAL	Partnerships Built on Trust	4F. Lead Program	Page 2
		Revision Date: 1/8/2024	Updated

HYGIENE FACILITIES AND PRACTICES: Washing Facilities Beeler shall ensure that, as a minimum, hand washing facilities are available to employees who may be exposed to lead. Employees shall be instructed to wash their hands and face prior to eating, drinking, smoking, or applying cosmetics and after the work shift. Workers will remove gloves, dispose of properly, and wash hands immediately after cutting lead and starting other lead-free tasks.

SIGNS: Beeler will post the following warning sign in work areas where an employee exposure to lead is above the PEL:

**WARNING
LEAD WORK AREA
POISON
NO SMOKING OR EATING**

SUMMARY RECAP

Use common sense & treat this as any other hazardous material you are working with. Wear gloves & protective clothing when applicable. Mechanically cut & do not heat up lead – this is when it becomes most hazardous. Additionally pay extra attention when working with lead line drywall and vacuum after each cut to ensure shavings are not kicked up & tracked. And last if you have any questions **ask your supervisor or safety director.**

 SAFETY & HEALTH MANUAL	Partnerships Built on Trust	5. Chemical Storage and Safety	Page 1
		Revision Date: 1/8/2024	Updated

Chemical Storage & Safety

PURPOSE: The purpose of this policy is to provide Beeler Construction employees and management with the information necessary for the safe and proper storage of chemicals on jobsites.

POLICY: Beeler Construction provides a safe and healthful workplace for all of its employees. All employees must become familiar with the following Chemical Storage & Safety section to avoid spills and possible contamination.

TRAINING: All Beeler Construction employees shall receive initial chemical safety training – including spill prevention and response procedures; additional training will be provided periodically. This training shall be documented with the employee name, date and trainer recorded. Training shall be conducted at a minimum annual basis or as needed whichever is sooner.

CHEMICAL PROTECTION REQUIREMENTS

General Requirements:

- 1) The Beeler Construction superintendent or foreman must ensure that the jobsite is free of an accumulation of unnecessary chemical materials. The superintendent or foreman has the authority to remove or dispose of such materials one hour after the responsible party has been notified.
- 2) Special emphasis to good housekeeping practices shall be taken with regard to chemical storage to prevent spills. Chemical containers/material shall never be allowed to accumulate or clutter in areas. Unused chemicals must be properly stored or if not used they shall be removed from the jobsite.
- 3) Chemicals should be properly stored to minimize any potential for a spill.
- 4) Poor or incorrect chemical storage practices can lead to inadvertent reaction between incompatible materials with potential to cause harm, fire or even explosions. Always review container labels and SDS sheets before storing different chemicals together to assure their compatibility.
- 5) Containers used for the storage and/or dispensing of chemicals must be of an approved type of metal construction and equipped with a self-closing lid and flash screen.
- 6) Storage of chemicals and inside of buildings at the jobsite must be kept to the minimum amount necessary.
- 7) Smoking is not allowed in areas where chemicals are being used or stored, including all paints.
- 8) Chemicals shall NOT be stored in areas used for exits, stairways or normally used for the safe passage for people.
- 9) Chemicals should be disposed of properly and in accordance with container labels and SDS sheets. Chemicals should never be disposed of in general construction dumpsters.

 SAFETY & HEALTH MANUAL	Partnerships Built on Trust	5. Chemical Storage and Safety	Page 2
		Revision Date:1/8/2024	Updated

▼ Chemical Spill Emergencies:

This is further outlined in Beeler Construction's Emergency Action Plans section of this manual.

Communication:

- 1) The first priority in the event of an emergency is the prompt communication of the emergency to all personnel at the project site and/or related field offices.
- 2) Communication of the existence of an emergency shall be by radio, cell phone or whatever means the employee has to announce the emergency, including existing alarm system or public address system, at jobsites so equipped.
- 3) Upon discovery of a spill, the employee must leave the immediate area and inform other employees of the spill in the area, unless the employee can safely contain or prevent the spread of the spill into other areas or into floor drains.
- 4) A foreman or superintendent, or other employee in absence of a foreman or superintendent, should inform occupants in adjacent buildings or occupancies of the existence, nature and location of the emergency.
- 5) If safe to do so, jobsite personnel shall call 911 and notify the fire department of the nature and location of the emergency within the building.

Evacuation:

- 1) After the emergency has been communicated, all employees must promptly and safely evacuate the facility.
- 2) All employees must NEVER run as they exit the building unless they must do so to escape the fire or spill.
- 3) Employees operating equipment that can be shut down in the immediate area where they are working can do so, **but only if it is safe to do so**, as they prepare to exit.
- 4) Employees evacuating the building may assist other employees if they are injured or disoriented, **but only if it is safe to do so**, as they prepare to exit.

▼ Spill Kits:

General Requirements:

- 1) Most facilities have some type of chemicals or other things that are dangerous, yet necessary for getting specific jobs done. Most of the time these products are used without any problem, but in the event of a spill, it is important to be able to get them contained and cleaned up as quickly and safely as possible. This is why it is so important to have a good spill kit available that can properly clean up the specific solution that is spilled.

 <p>Partnerships Built on Trust</p> <p>SAFETY & HEALTH MANUAL</p>	<p>5. Chemical Storage and Safety</p>	<p>Page 3</p>
	<p>Revision Date:1/8/2024</p>	<p>Updated</p>

- 2) It is so important in fact that there are OSHA spill kit requirements that must be in place when working with certain types of chemicals and other products that could be spilled. Understanding these requirements will not only ensure you are in compliance with the rules and regulations, but it will also help keep your employees and your facility as safe as possible.
- 3) Beeler Construction shall review each project in specific to assess spill kit requirements. The review will be between the safety director, project manager and the site superintendent/foreman. If deemed necessary, the appropriate spill kit will be provided.

Types of Spill Kits:

Spill kits are specific to the type of chemical spill, only a kit specific to the type of chemical shall be used.

1) Universal Spill Kit

The most common type of spill kit is typically known as a “universal spill kit”. This option is made to be able to clean up a wide range of different spills. While not made specifically for any one type of spill, the vast majority of facilities will be able to use this type of kit. Universal spill kits are able to easily clean up oil based products, water based products and many chemicals. The following items should be found in an OSHA spill kit of this type:

- **Safety Gloves:** Having nitrile gloves will provide protection to the person cleaning up a spill. These types of gloves are resistant to corrosion from chemicals.
- **Eye Goggles:** If even a small amount of many chemicals, oils or other things get in the eyes, it can cause severe problems. This is why it is so important to keep your eyes protected with these goggles.
- **Shoe Covers:** It is often necessary to step in the spill while cleaning it up and these shoe covers will protect your shoes and your feet.
- **Sorbents:** The absorbent items that will actually clean up the spill need to be able to quickly absorb and hold in a variety of liquids. OSHA spill kits can have any number of types of sorbents. Most will have larger pads to put over the spill, pillows to contain and absorb the spill and smaller sorbent socks.
- **Handbook:** Having the information you need to stay safe during a spill is also important. Most good spill kits will contain a book that helps you determine the potential dangers associated with cleaning up a specific type of spill.
- **Disposal Bag:** Having a large bag or other storage bin that can hold everything after it has been used until it can be properly disposed of it absolutely essential.

 Partnerships Built on Trust SAFETY & HEALTH MANUAL	5. Chemical Storage and Safety	Page 4
	Revision Date:1/8/2024	Updated

2) **Battery Acid Spill Kit**

If you work in an area where large, powerful batteries are present, it is important to have an OSHA approved battery acid spill kit. These are different than other options because they can clean up the very corrosive battery acid safely. Many things such as the nitrile gloves, eye goggles and storage bags.

In addition to these standard items, the battery acid spill kits also have a poly apron to help protect your clothes from getting holes in them if the acid comes in contact with them. Having a special polymer that will neutralize the acid is also very important as it can minimize any damage during and after the cleanup process. While not always required, most spill kits of this type will have a scoop to help pick all the acid up.

3) **Mercury Spill Kit**

Mercury can be very dangerous but it is a necessary element in things like fluorescent light bulbs, many types of thermometers and some lab equipment. Mercury spill kits need to contain amalgamation powder, indicator powder to make sure it is all cleaned up, a vapor suppressor bottle, an aspirator bottle and a chemical sponge to absorb all the mercury. This is, of course, in addition to all the standard items included in all OSHA spill kits.

4) **Biohazard Spill Kit**

If any biological spill occurs, including blood, this type of kit can be very effective. These kits are also known as bloodborne pathogen spill kits. It is used to safely absorb just about any type of bodily fluids quickly and sanitarly. This type of kit is different than many of the other OSHA spill kit requirements. The following items should be in any biohazard spill kit:

- **Bio-hazard Sorbents:** These are special sorbents that are made to absorb and secure biological materials. They can come in many shapes and sizes including large mats, thick pillows and more.
- **Neoprene Gloves:** These will help ensure nothing gets onto your hands. Many kits will have gloves with longer sleeves to help keep all the biological materials off your wrist and arms too.
- **Sanitizing Surface Wipes:** Once you've cleaned up all the visible biological materials, you'll want to sanitize all surfaces with these wipes. They are made to kill any bacteria or virus that is left behind.
- **Sanitizing Hand Wipes:** While you should ideally shower as quickly as possible after cleaning up a biological spill, these wipes will sanitize your hands and arms until that is possible.

 Partnerships Built on Trust SAFETY & HEALTH MANUAL	6. Personal Protective Equipment	Page 1
	Revision Date: 1/8/2024	Updated

Personal Protective Equipment

PURPOSE: The purpose of this procedure is to provide requirements for the use of personal protective equipment to be used during the performance of certain tasks and work activities. All Beeler Construction employees shall wear or use the personal protective equipment detailed in this procedure and shall be trained in the hazards present in their work that can be protected through the use of personal protective equipment.

POLICY: Beeler Construction provides a safe and healthful workplace for all of its employees. This procedure details the personal protective equipment that is to be used by employees. This procedure applies to all Beeler Construction facilities, jobsites and employees and will be strictly enforced.

TRAINING: All Beeler Construction employees shall receive initial PPE training. Employees shall be trained in when to wear PPE's, what type of PPE's should be worn, techniques on how to wear and remove PPE's, the limitations of PPE's and the care and maintenance of PPE's. This training is to be documented; employee name, date, type of PPE training and the trainer will be recorded.

Prior to wearing/using PPE's, each employee must demonstrate their ability to effectively use each type of PPE required. If needed, employee will be retrained until they can show that they can effectively use PPE's. Further retraining may be required should changing workplace conditions deem it necessary.

EQUIPMENT: Beeler Construction shall provide all necessary PPE's and which will be in compliance with OSHA 29 CFR 1926 Subpart E. If an employee provides their own PPE's, these must be reviewed/inspected by the Beeler Construction safety director to assure their adequacy and confirm their compliance.

PPE equipment should be comfortable and should properly fit the employee. Poorly fitting equipment will not afford the necessary protections and employees are less likely to wear equipment if it is uncomfortable. Protective equipment and devices are generally available in varying sizes; attention should be given to utilizing the proper size of the PPE.

 Partnerships Built on Trust SAFETY & HEALTH MANUAL	6. Personal Protective Equipment	Page 2
	Revision Date: 1/8/2024	Updated

PROCEDURES:

▼ Inspection and Maintenance

All PPE's must be inspected prior to use, damaged equipment is to be immediately repaired or replaced, and/or removed from the jobsite. Employees must properly maintain and keep equipment clean and sanitary and in reliable condition. Unkempt PPE's must be immediately replaced and discarded or removed from the jobsite.

▼ Hazard Assessment

Prior to the start of any task, a hazard assessment should take place to address required PPE use. Please see "PPE Hazard Assessment Instructions" at the end of this section.

▼ Head Protection:

Impact resistant head protection in compliance with OSHA 29 CFR 1926.100 shall be provided and worn by employees during the following operations:

- ✓ At all times at Beeler Construction jobsites. This policy also applies to all visitors and subcontractor drivers and suppliers that are on the jobsite.

▼ Safety Vests/High Visibility

Safety vests must be worn anytime flagging operations or exposure to public vehicular traffic is present per OSHA 1926.201 and 1926.651. High visibility should also be considered anywhere moving equipment is being used inside or outside (such as scissors or electric boom lifts). The entire jobsite may be designated as a high visibility area by Beeler Construction.

▼ Eye & Face Protection:

Safety Glasses with Side Shields:

Safety glasses are **REQUIRED** at all times when inside construction work areas. All safety glasses used to protect against eye hazards must meet the requirements of ANSI Z87.

 Partnerships Built on Trust SAFETY & HEALTH MANUAL	6. Personal Protective Equipment	Page 3
	Revision Date: 1/8/2024	Updated

Goggles:

Goggles designed to protect the eyes from contact with splashed chemicals, liquids, or other debris or eye hazards shall be worn during the following operations:

- ✓ Transfer of chemicals from one container to another
- ✓ Other operations where the use of safety glasses does not provide adequate protection from dust or debris present in the work area

Other Eye & Face Protection:

Other forms of face and eye protection, such as full face shields and welding goggles and helmets shall be worn when performing the following tasks:

- ✓ Tinted goggles may be used in place of tinted face shields when using gas torches for metal burning
- ✓ Full face shields and chemical goggles or safety glasses shall be worn during times that materials are being used or sprayed that can cause damage to eyes and skin. Such operations may include corrosive cleaning materials, high pressure water spraying equipment, or sealants that contain chemicals
- ✓ Full face shields are required whenever working on energized electrical systems
- ✓ Full face shield should be used whenever using a hand held grinder where excessive debris is being broadcast from the operation

▼ Foot Protection:

All employees must wear footwear substantial enough to protect against dropped materials injuring the toes or feet. The footwear must provide adequate protection against accidental contact with tools and materials and against sharp or pointed objects that may be present at the job. A steel toe and steel shank are desirable to prevent injury from nails and other sharp objects that can cause injury when stepped on.

Employees are responsible for maintaining the condition of their footwear. Footwear must be replaced or repaired if holes are present in soles or other portions of the shoe or if soles separate from the upper portion of the shoe or boot. Shoes and boots are to be completely laced and tied at all times.

 Partnerships Built on Trust SAFETY & HEALTH MANUAL	6. Personal Protective Equipment	Page 4
	Revision Date: 1/8/2024	Updated

▼ **Hand Protection:**

Gloves shall be provided and worn whenever handling material which could tear, cut, burn, irritate, pinch or otherwise injure the hands or fingers. The type of glove worn should be selected based upon the hazard being protected against. Examples of situations where gloves are required include:

<u>Operation/Hazard</u>	<u>Type of Glove</u>
Handling wire rope	Leather
Handling lumber	Leather
Handling metal with sharp edges	Leather
Handling corrosives and solvents	PVC or Nitrile
Welding/cutting	Leather

▼ **Respiratory Protection:**

Respiratory protection is required during times that Beeler Construction employees are exposed to the hazards associated with exposure to airborne dusts and contaminants generated during various operations performed by Beeler Construction subcontractors and employees. For specifics concerning respirator selection and use, the Beeler Construction written respiratory protection program should be referred to.

▼ **Personal Fall Arrest Equipment:**

Personal fall arrest equipment may be used when other forms of fall protection are not available or feasible. Employees must be protected from falls when the exposure to a fall from one level to another level of the building exceeds 6 feet.

Personal fall arrest equipment consists of a full body harness and a D-ring attachment on the back of the harness. A shock absorbing lanyard with double locking snap hooks not exceeding 6 feet in length is typically used to “tie off” to a secure anchor point; retractable lanyards also can be used in similar fashion. The anchor point must be capable of supporting at least 5,000#. Employees must NEVER use plastic or cast iron vent lines, wood guard rails, or other unstable objects as points of attachment.

Personal fall arrest equipment should be inspected prior to each use each day for cuts or fraying in the webbing or on the rope for deformities in any metal parts, or for other defects that could affect the system’s strength.

 Partnerships Built on Trust SAFETY & HEALTH MANUAL	6. Personal Protective Equipment	Page 5
	Revision Date: 1/8/2024	Updated

▼ **Clothing:**

General Requirements for Clothing:

Clothing should be worn that is suitable and compatible with the work being performed. Long pants are required to protect the legs from contact with materials, tools, and equipment that can scrape or lacerate skin tissue. Pants should be made from a substantial cotton, denim, or other material that can provide this type of protection. Pants that are extensively torn or ragged should not be worn as they are no longer able to provide protection against scrapes and cuts and may become entangled in machinery and equipment.

Shirts should also be selected for the protection that they can provide the wearer. Long sleeved shirts are preferred because of the extra protection they provide the forearm and elbow. Cuffs should always be buttoned on long sleeve shirts to prevent the cuff or sleeves from becoming caught on, or entangled in, materials, machinery or equipment.

Clothing should also be selected for the protection provided during periods of poor weather. Rain apparel should be worn to keep clothing dry during times when cold and rainy conditions exist. Multiple layers of clothing should be worn during periods of extreme cold and all areas of exposed skin should be protected. Hard hat liners should be used to prevent excessive heat loss which occurs primarily through the head. Clothing should also be selected and worn to protect against the effects of intense sunlight and resulting burns caused by prolonged exposure to the sun's ultraviolet radiation. Persons particularly susceptible to sunburn should try to cover as much of their body as possible to prevent sunburn.

The foreman or superintendent is responsible for ensuring that employees are properly attired for the work being performed. In some cases, employees may be sent home until they return in clothing suitable for the job. Special caution should be taken to avoid wearing jewelry which can become caught and entangled in materials, machinery and equipment. Rings, necklaces, loose fitting watches, etc. are examples of jewelry that can cause injury as a result of becoming caught on or in materials and machinery.

Special Protective Clothing:

Certain types of work require special protective clothing. This clothing must be worn when performing the following operations:

 SAFETY & HEALTH MANUAL	Partnerships Built on Trust	6. Personal Protective Equipment	Page 6
			Revision Date: 1/8/2024

- ✓ Long sleeve shirts and pants must be worn when working with hot materials to prevent thermal burns to the skin
- ✓ Leather aprons, jackets or flame resistant clothing must be worn when welding or burning operations expose the employee to molten metal or hot slag

▼ PPE Hazard Assessment Instructions:

Based on the hierarchy of controls, PPE is a last resort. Personal protective equipment alone should **not** be relied upon to provide protection against hazards, but should be used in conjunction with engineering controls, administrative controls, and procedural controls.

This document addresses eye, face, head, hand, foot, torso, respiratory, noise, and fall protection. It will serve as the Personal Protective Equipment (PPE) Certification document required to satisfy the federal requirements of the Occupational Safety and Health Administration (OSHA) Standard, 29 CFR 1910.132 Subpart I - Personal Protective Equipment.

General Guidelines:

The PPE Hazard Assessment can be conducted for an area, a job category or for an individual by selecting and filling in the appropriate box. The assigned evaluator shall include their name, department/division being assessed and the date. Completed assessments must be accessible to employees and inspectors and updated when needed.

PPE Hazard Assessment Instructions:

Step 1: Inform affected employees of the process:

Affected employees from each work area that is being assessed should be involved in the process. Discuss the reasons for the survey and the procedures being used for the assessment. Review the job procedures, potential hazards and the PPE currently in use.

Step 2: Review data:

Reports of work-related injuries or illnesses, near-miss events and reported safety concerns are sources of data that can provide helpful information for assessing hazards.

Step 3: Conduct a walk-through survey:

The purpose of the survey is to identify sources of hazards to employees. Observe the following: layout of the workplace, location of the employees, work operations, hazards

 Partnerships Built on Trust SAFETY & HEALTH MANUAL	6. Personal Protective Equipment	Page 7
	Revision Date: 1/8/2024	Updated

and places where PPE is currently used including the device and reason for use. Using the form, check the type of hazard(s) present within each section (organized by body part). Further descriptions can be provided in the adjacent box. Consideration should be given to the following basic hazard categories:

- 1) Impact (falling/flying objects)
- 2) Penetration (sharp objects piercing foot/hand)
- 3) Compression (roll-over or pinching objects)
- 4) Chemical exposure (inhalation, ingestion, skin contact, eye contact or injection)
- 5) Temperature extremes (heat/cold)
- 6) Dust/flying debris (grinding, chipping, sanding, etc.)
- 7) Fall (slip/trip, scaffolds, elevated work)
- 8) Radiation (non-ionizing: UV/IR/light, welding, brazing, cutting, furnaces, etc.)
- 9) Noise (mechanical rooms, machines, cage washing, jackhammers, etc.)
- 10) Electrical (shock, short circuit, arcing, static)

Step 4: Select PPE:

After considering and/or planning for other controls, select the PPE which provides at least the minimum level of protection required to protect employees from the hazards. Using the form, note the appropriate PPE in the required PPE box. For help with proper PPE selection, contact OESO or consult the guides found on the OESO-OHS Chemical Hygiene webpage: www.safety.duke.edu/OHS/PPE.htm.

Step 5: Make Document Accessible:

Once completed, signed and dated, store the form either electronically or as a hard copy in a location easily accessible to employees and inspectors.

Step 6: Revise Protocol:



Update departmental protocols with the new or modified PPE requirements if applicable.

Step 7: Reassess the workplace as necessary by identifying and evaluating:

- 1) New equipment and processes
- 2) Accident records
- 3) Suitability of previously selected PPE

 Partnerships Built on Trust SAFETY & HEALTH MANUAL	6. Personal Protective Equipment	Page 8
	Revision Date: 1/8/2024	Updated

PPE HAZARD ASSESSMENT FORM

I am reviewing (check the appropriate box):	<input checked="" type="checkbox"/> A worksite	Specify location:	
	<input type="checkbox"/> A single employee's job description	Name of employee:	
	<input type="checkbox"/> A job description for a class of employees	Position Title:	
	<input type="checkbox"/> A job description for a class of employees	Position Titles: Location:	
Your Name:		Department/Division:	
Date:			
	EYE HAZARDS: Tasks that can cause eye injury include: working with chemicals or acids; UV lights; chipping, sanding, or grinding; welding; furnace operations; and metal and wood working.		
	<i>Check the appropriate box for each hazard:</i>		
	Chemical Exposure <input type="checkbox"/>	<i>Description of hazard(s):</i>	<i>Required PPE</i>
	High Heat/Cold <input type="checkbox"/>		
	Dust/Flying Debris <input type="checkbox"/>		
	Impact <input type="checkbox"/>		
	UV/IR Radiation <input type="checkbox"/>		
Other:			
	HEAD/NECK/FACE HAZARDS: Tasks that can cause head/neck/face injury include: working below other workers who are using tools or materials that could fall, working on energized electrical equipment or utilities, and working in trenches or confined spaces.		
	<i>Check the appropriate box for each hazard:</i>		
	Chemical Exposure <input type="checkbox"/>	<i>Description of hazard(s):</i>	<i>Required PPE</i>
	Dust/Flying Debris <input type="checkbox"/>		
	Impact <input type="checkbox"/>		
	UV/IR Radiation <input type="checkbox"/>		
	Electrical Shock <input type="checkbox"/>		
Other:			
	FOOT HAZARDS: Tasks that can cause foot injury include: exposure to chemicals or acids, welding or cutting, materials handling, renovation or construction, and electrical work.		
	<i>Check the appropriate box for each hazard:</i>		
	Chemical Exposure <input type="checkbox"/>	<i>Description of hazard(s):</i>	<i>Required PPE</i>
	High Heat/Cold <input type="checkbox"/>		
	Impact/Compression <input type="checkbox"/>		
	Electrical <input type="checkbox"/>		
	Puncture <input type="checkbox"/>		
Slippery/Wet Surfaces <input type="checkbox"/>			
Other:			



Partnerships
Built on Trust

SAFETY & HEALTH MANUAL





6. Personal Protective Equipment

Page
9

Revision Date: 1/8/2024

Updated

PPE HAZARD ASSESSMENT CERTIFICATE

	HAND HAZARDS: Hand injury can be caused by: work with chemicals or acids, exposure to cut or abrasion hazards (for example, during demolition, renovation, woodworking, or food service preparation), work with very hot or cold objects or materials, and exposure to sharps.		
	<i>Check the appropriate box for each hazard:</i>		
	<input type="checkbox"/>	<i>Description of hazard(s):</i>	<i>Required PPE</i>
	Chemical Exposure		
	High Heat/Cold		
	UV/IR Radiation		
	Electrical Shock		
Puncture			
Cuts/Abrasion			
Other:			
	BODY HAZARDS: Injury of the body (torso, arms, or legs) can occur during: exposure to chemicals, acids, or other hazardous materials; abrasive blasting; welding, cutting, or brazing; chipping, sanding, or grinding; use of chainsaws or similar equipment; and work around electrical arcs.		
	<i>Check the appropriate box for each hazard:</i>		
	<input type="checkbox"/>	<i>Description of hazard(s):</i>	<i>Required PPE</i>
	Chemical Exposure		
	High Heat/Cold		
	Impact/Compression		
	Electrical Arc		
Cuts/Abrasion			
Other:			
	FALL HAZARDS: Personnel may be exposed to fall hazards when performing work on a surface with an unprotected side or edge that is 4 feet or more above a lower level, or 10 feet or more on scaffolds. Fall protection may also be required when using vehicle man lifts, elevated platforms, tree trimming, performing work on poles, roofs, or fixed ladders.		
	<input type="checkbox"/>	<i>Description of hazard(s):</i>	<i>Required PPE</i>
	NOISE HAZARDS: Personnel may be exposed to noise hazards when working in mechanical rooms; machining; grinding; sanding; cage washing; dish washing; working around pneumatic equipment, grounds equipment, generators, chillers, motors, saws, jackhammers, or similar equipment.		
	<input type="checkbox"/>	<i>Description of hazard(s):</i>	<i>Required PPE</i>
	RESPIRATORY HAZARDS: Personnel may be exposed to respiratory hazards that require the use of respirators: during emergency response, when using certain chemicals outside of a chemical fume hood; when working with hazardous powders; when entering fume hood plenums, when working with animals; when applying paints or chemicals in confined spaces; when welding, cutting, or brazing on certain metals; and when disturbing asbestos, lead, silica, or other particulate hazards.		
	<i>Check the appropriate box for each hazard:</i>		
	<input type="checkbox"/>	<i>Description of hazard(s):</i>	<i>Required PPE</i>
	Chemical exposure		
<input type="checkbox"/>			
Particulate exposure			
Other:			

I certify that the above hazard assessment was performed to the best of my knowledge and ability, based on the hazards present on this date.



Partnerships
Built on Trust

SAFETY & HEALTH MANUAL

6. Personal Protective Equipment

Page
10

Revision Date: 1/8/2024

Updated

 <p>Partnerships Built on Trust</p> <p>SAFETY & HEALTH MANUAL</p>	7. Electrical	Page 1
	Revision Date: 1/8/2024	Updated

Electrical Safety

POLICY: Beeler Construction provides a safe and healthful workplace for all of its employees. This procedure covering electrical safety applies to all Beeler Construction jobsites, employees and subcontractors and will be strictly enforced.

PURPOSE: The purpose of this procedure is to provide requirements for the use of electrical safety appliances to protect against the hazard of electrical shock and injury that exist during the use of electrically powered equipment at each jobsite.

TRAINING: All Beeler Construction employees shall receive initial electrical safety and awareness training and periodic training thereafter. All training is to be provided by a qualified person. All training is to be documented, employee name, date of training and trainer will be recorded.

PROCEDURES:

Safety related work place practices shall be employed to prevent shock or other injuries resulting from either direct or indirect electrical contacts, when work is performed near or on equipment or circuits which are or may be energized. The specific safety related work practices shall be consistent with the nature and extent of the associated electrical hazards.

▼ Work Place Safety Procedures

To minimize electrical hazards, the following steps or procedures must be completed on all Beeler Construction projects and must also be completed by all Beeler Construction subcontractors working at any Beeler Construction projects.

- 1) Preplan the project to identify and minimize electrical hazards. Such preplanning activities shall include, but not necessarily be limited to, a site survey to identify pre-existing electrical hazards and conditions.
- 2) Design a safe, temporary electrical system that anticipates project needs. Such a system must include and address adequate and safe access to temporary power throughout the duration of the project. The system must also include adequate lighting and safe routing of electrical cables that feed branch circuits. All power distribution units (PDU's) and turtles must be routed so that no branch circuit conductors are laid on the floor.
- 3) Design and implement a plan to transition the project from temporary power to permanent power.
- 4) Identify potential electrical disruptions at the project and communicate the potential disruptions and the protections to successfully mitigate any such disruptions to the project owner or any others that could be impacted by a disruption.

 Partnerships Built on Trust	7. Electrical	Page 2
	Revision Date: 1/8/2024	Updated

SAFETY & HEALTH MANUAL

- 5) Create and implement an electrical inspection plan to verify that equipment, electrical systems, tools and electrical cords used at the project meet or exceed the applicable OSHA, NEC, UL and NFPA standards.

▼ Standards and Instructions:

General Requirements:

- 1) All electrical equipment used on a project site shall be free from hazards that could cause death, injury or physical harm. All equipment, electrical systems, tools and electrical cords used at the project must meet or exceed the applicable OSHA, NEC, UL and NFPA standards.
- 2) Only electrical equipment that lists the identifications below, on the equipment, may be used on a Beeler Construction project.
 - ✓ Manufacturer of the equipment
 - ✓ Voltage, current and wattage of the equipment
 - ✓ If applicable, other electrical ratings commonly identified on the specific equipment
- 3) Only electrical equipment listed by an industry-recognized, approved testing laboratory shall be allowed on site. One such industry-recognized, approved testing laboratory is Underwriters Laboratories. Testing laboratories other than Underwriters Laboratories may be considered on a case-by-case, equipment-by-equipment basis. All electrical installation and electrical work shall conform to the National Electric Code, the ANSI Safety Code and all applicable federal, state and local codes and legal requirements, including any requirements of OSHA or the state-specific OSHA requirements.
- 4) Each disconnect or breaker, whether temporary or permanent, must be clearly marked to indicate its purpose.
- 5) Electrical work shall be performed by qualified employees who have been trained on the requirements of applicable electrical codes, such as the National Electric Code, the ANSI Safety Code and all applicable federal, state and local codes and legal requirements and who are qualified for the class of work to be done. This requirement shall apply to employees of all subcontractors and employees of a subcontractor of any tier.
- 6) Unqualified personnel shall not work within any limited approach boundary of any exposed, energized electrical conductors or circuit parts. A limited approach boundary is the shock protection boundary established around exposed, energized electrical conductors or circuit parts.
- 7) Beeler Construction's Lockout/Tagout program or an equal program must be followed when performing any repair work or maintenance work of electrical equipment. The Lockout/Tagout program is addressed in Section 14 of this manual. All electrical circuits shall be considered hot (live) and shall be tested prior to commencing work on the electrical circuits.
- 8) Employees may not enter spaces containing exposed energized parts unless ample illumination is provided that enables the employees to work safely.
- 9) Protective shields, barricades or insulating materials shall be provided as necessary when working around energized parts.

 Partnerships Built on Trust	7. Electrical	Page 3
	Revision Date: 1/8/2024	Updated
SAFETY & HEALTH MANUAL		

- 10) All portable ladders used around energized parts shall be constructed of non-conductive material such as wood or fiberglass or have non-conductive side rails.
- 11) When working around energized parts, only non-conductive apparel shall be worn unless it is rendered non-conductive by covering, wrapping or other insulating means. Conductive items of jewelry shall not be worn.

Temporary Power:

- 1) All temporary power systems exposed to weather elements must be weatherproofed.
- 2) Conduit for underground temporary power feeds for the project site that are installed by the electrical subcontractor or its sub-subcontractors of any tier shall be encased in concrete or marked with red plastic detectable warning tape 18 inches above the line.
- 3) Because underground temporary power is not typically registered with a state's one-call system, subcontractors conducting underground work shall not rely on the local one-call system to locate project-specific temporary power such as, but not limited to, project feed and tower cranes. Subcontractors must take action to positively locate the temporary service.
- 4) All underground or overhead temporary power feeds shall be clearly marked on the site utilization plan.
- 5) All 120-volt, single-phase, 15 and 20 ampere receptacles for employee use during construction activities must be protected by a Ground Fault Circuit Interrupter system (GFCI). Assured equipment grounding conductor program shall not be used on 120-volts, however can be used on voltage greater than 120 volts. All GFCI's that are part of a temporary electrical system must be tested monthly. The type and frequency of tests to be performed by an electrical subcontractor on a Beeler Construction project should be included in the subcontract agreement. In the absence of any reference in the subcontract agreement, tests must be performed as frequently as reasonably possible to ensure safe operation at the project.
- 6) At construction projects performing new work, as opposed to remodeling, GFCI protection may be accomplished by either installing approved GFCI-type breakers inside panel boxes or providing approved GFCI receptacles.
- 7) Any construction-related cord set or electrical equipment plugged into existing permanent power receptacles must be protected by a GFCI.
- 8) When a portable GFCI is used in a non-GFCI receptacle, the GFCI must be plugged in at the power source (receptacle) end and not at the tool end. Portable GFCI's must be tested before each use.

Temporary Lighting:

- 1) Adequate lighting must be provided throughout the building and in all work areas, particularly in passageways and stairways. Temporary lights shall be equipped with guards to prevent accidental contact with the bulbs. Guards must protect all sides including the bottom of the bulb. Broken or burned out lamps must be promptly replaced.
- 2) Temporary lights and extension cords must be equipped with heavy duty electric cords. All connections and insulation must be maintained in safe condition. All



Partnerships
Built on Trust

SAFETY & HEALTH MANUAL

7. Electrical

Page
4

Revision Date: 1/8/2024

Updated

splices and joints and the free ends of conductors shall be covered with an insulation equivalent to that of the conductor's insulation or with an insulating device identified for the purpose of providing such insulation. See NEC 110.14(B) for requirements.

- 3) Temporary lights must not be hung by their cords unless the cords are designed or such a purpose. Cable assemblies and flexible cords and cables shall be supported in place at intervals that protect against physical damage. Supports shall be in the form of cable ties, straps or similar types of fittings installed in a way that does not cause damage to the temporary light's cord. See NEC 590.4(J) for requirements.
- 4) Temporary lights must not be hung by their cords unless the cords are designed for such a purpose. Cable assemblies and flexible cords and cables shall be supported in place at intervals that protect against physical damage. Supports shall be in the form of cable ties, straps, or similar types of fittings installed in a way that does not cause damage to the temporary light's cord. See NEC 590.4(J) for requirements.

The light shown below is guarded but is not supported, and its wires are not protected.



The bottom of the light shown below is not guarded from contact.



The picture below shows a properly installed temporary light.



The picture below shows a properly suspended temporary light wiring.



Interior nonmetallic-sheathed cable ("NM"), also known as Romex® cable, may be used for temporary lighting when installed per the National Electrical Code (NEC), local building codes, and if allowed by applicable OSHA requirements.

 Partnerships Built on Trust	7. Electrical	Page 5
	Revision Date: 1/8/2024	Updated
SAFETY & HEALTH MANUAL		

▼ De-energizing:

Whenever possible, all live parts and equipment that an employee can come in contact with, the power shall be de-energized before the employee works on them. As an extra precaution, all de-energized parts should always be considered as live; this applies in situations where equipment has been de-energized but has not been locked out or tagged out.

If the power cannot be de-energized per the NFPA 70E requirements, the qualified electrician shall fill out a hot work permit and follow NFPA 70E hot work requirements. Safety related work practices shall be used to protect employees who may be exposed to the electrical hazards involved. Such practices shall protect employees against direct contact with circuits or parts with any part of their body or through a conductive object or material. Only qualified and specifically trained employees shall be allowed to work on or around energized parts and equipment. Whenever possible, non-conductive or safety rated insulated tools are to be used. Particular attention shall be considered to the use of PPE's (rubber gloves, face shields, etc.) when working on or around energized equipment.

▼ Overhead Lines:

- 1) The minimum work distance from an overhead power line for unqualified employees is 10'. If an unqualified worker is required to perform tasks within 10', the power line must be de-energized by the local utility company.
- 2) When an unqualified person is working in an elevated position near energized overhead lines, the location shall be such that the person and the longest conductive object he or she may contact cannot come closer to any unguarded energized overhead lines than the following distances:
 - ✓ For voltages to ground 50kV or below 10"
 - ✓ For voltages to ground over 50kV 10" plus 4" for every 10kV over 50kV
- 3) All vehicles and equipment must maintain a clearance of 10' or greater from any energized overhead lines
- 4) Any vehicle or equipment capable of having parts of its structure elevated near energized overhead lines cannot come closer to unguarded energized overhead lines than the following distance:
 - ✓ For voltages to ground 50kV or below 10"
 - ✓ For voltages to ground over 50kV 10" plus 4" for every 10kV over 50kV
- 5) When a qualified person is working in the vicinity of overhead lines, whether in an elevated position or on the ground, the person may not approach or take any conductive object without an approved insulating handle closer to exposed energized parts than shown in Table S5 below:

TABLE S-5
APPROACH DISTANCES FOR QUALIFIED EMPLOYEES - ALTERNATING CURRENT

Voltage range (phase to phase)	Minimum approach distance
300V and less	Avoid Contact
Over 300V, not over 750V	1 ft. 0 in. (30.5 cm)
Over 750V, not over 2kV	1 ft. 6 in. (46 cm)
Over 2kV, not over 15kV	2 ft. 0 in. (61 cm)
Over 15kV, not over 37kV	3 ft. 0 in. (91 cm)
Over 37kV, not over 87.5kV	3 ft. 6 in. (107 cm)
Over 87.5kV, not over 121kV	4 ft. 0 in. (122 cm)
Over 121kV, not over 140kV	4 ft. 6 in. (137 cm)

▼ **Portable Electrical Generators:**

- 1) Portable electrical generators supplied by Beeler Construction or subcontractors shall only be used with a GFCI extension cord/outlet located between the generator receptacle and tool or equipment being used.
- 2) A generator that is equipped with GFCI receptacles integral to the generator will not require the use of additional GFCI extension cords or outlets.

▼ **Equipment Inspection:**

- 1) All electrically powered equipment must be inspected prior to each use.
- 2) Worn, damaged, frayed or equipment missing electrical components shall be removed from use and repaired before using.
- 3) It shall be the responsibility of each employee to routinely inspect electrical tools, equipment and extension cords to determine if it is worn, damaged, frayed or missing important components.
- 4) Ground fault circuit interruption equipment, receptacles and circuits will be tested by “pushing” or “tripping” buttons or switches on receptacles, outlets, cords or breakers to ensure that power is disconnected when “tripped.”
- 3) Inspect electrical panels for: A minimum of 3-foot-deep by 30-inch-wide clear space in front of all live electrical panels. The picture below shows an unacceptable condition on Beeler Construction projects.



 Partnerships Built on Trust SAFETY & HEALTH MANUAL	7. Electrical	Page 7
	Revision Date: 1/8/2024	Updated

▼ **Enforcement:**

Use of 120-volt electrical tools and equipment not protected by a GFCI protected device shall be considered a serious safety violation. Lack of inspecting, testing and color coding extension cords and tool cords per the Assured Equipment Grounding Conductor Program will also be considered a safety violation. Employees will be subject to disciplinary action including possible termination.

▼ **Assured Grounding Program**

- Shall only be used with power distribution units “PDU” and turtle system cords.

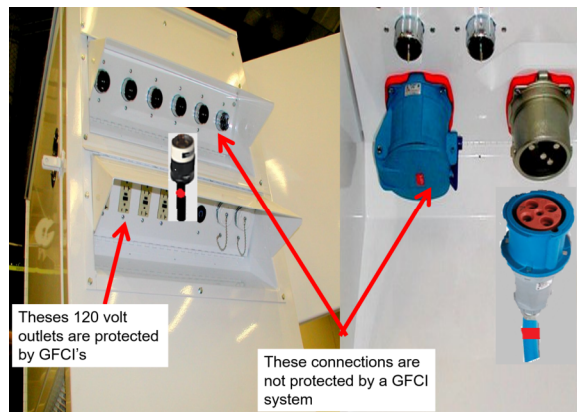

Turtle System

PDU

- OSHA requires that a written description of the employer’s assured equipment grounding conductor program, including the specific procedures adopted, be kept at the jobsite. This program should outline the employer’s specific procedures for the required equipment inspections, tests, and test schedule.
- The required tests must be recorded, and the record maintained until replaced by a more current record. The written program description and the recorded tests must be made available, at the jobsite, to OSHA and to any affected employee upon request.



Partnerships
Built on Trust

SAFETY & HEALTH MANUAL

7. Electrical

**Page
8**

Revision Date: 1/8/2024

Updated

As an easy reminder of the color of the tape to place on the newly tested cord, remember the color for the start of each calendar quarter by the season:

White in January for Winter

Green in April for Spring

Red in July for Summer, or the 4th of July

Orange in October for Fall, or pumpkins.

Assured Equipment Grounding Conductor Program Color Code			
Month #	Month Tested	Color of tape(s) to apply to cord	
1	January	White	
2	February	White +	Yellow
3	March	White +	Blue
4	April	Green	
5	May	Green +	Yellow
6	June	Green +	Blue
7	July	Red	
8	August	Red +	Yellow
9	September	Red +	Blue
10	October	Orange	
11	November	Orange +	Yellow
12	December	Orange +	Blue

 Partnerships Built on Trust	8. Scaffolding Safety	Page 1
	Revision Date: 18/2024	Updated

SAFETY & HEALTH MANUAL

Scaffolding Safety

PURPOSE: The purpose of this procedure is to provide requirements for the safe use, erection and dismantlement of scaffolding used by Beeler Construction employees and employees of subcontractors. This document is a summary of OSHA’s comprehensive requirements contained in 29 CFR 1926, Subpart L concerning the use of scaffolding and other elevated work platforms.

POLICY: Beeler Construction provides a safe and healthful workplace for all of its employees. This procedure summarizes the main requirements of OSHA’s comprehensive scaffolding and elevated work platform requirements. This procedure applies to all jobsites, activities and situations where Beeler Construction employees and subcontractor employees erect, dismantle and use scaffolding.

TRAINING: All Beeler Construction employees receive initial scaffolding safety training as outlined in this section and periodic training thereafter. Training topics include; scaffolding capacity, scaffold platform construction, accessing scaffolds, scaffold use, scaffold use around power lines, fall protection, falling object protection, and general requirements for supported scaffold and mobile/rolling scaffolds. All training is to be provided by a qualified person that is competent in scaffolding safety. Training is to be documented, employee name, date of training and trainer will be recorded.

Beeler Construction employees will be retrained as required when circumstances are deemed necessary such as: an employee does not demonstrate proficient knowledge of scaffolding safety set forth by this chapter, where changes on site present a hazard that the employee has not been trained, where changes in the types of scaffolds, fall protection or other equipment present a hazard that the employee has not been trained.

PROCEDURES:

▼ General Requirements:

Capacity:

- 1) All scaffolding and scaffolding components must be capable of supporting its own weight and at least 4 times the maximum intended load.

 <p>Partnerships Built on Trust</p> <p>SAFETY & HEALTH MANUAL</p>	<p>8. Scaffolding Safety</p>	<p>Page 2</p>
	<p>Revision Date: 18/2024</p>	<p>Updated</p>

Scaffold Platform Construction:

- 1) Employees erecting scaffolding must wear hard hats.
- 2) Platforms on all working levels of scaffolds must be fully planked or decked.
- 3) Space between the platform and uprights must be 1inch or less, unless the subcontractor can demonstrate that a wider space is necessary, such as on Morgan tower scaffolding.
- 4) If a Morgan tower is utilized the open space between the platform and the uprights must not exceed 9½ inches.
- 5) Platform width must be a minimum of 18 inches except ladder jack & pump jack scaffolding.
- 6) The cantilevered ends of scaffold platforms must overhang its end support no less than 6 inches or more than 12 inches.
- 7) On scaffolds where planks or platforms overlap to form a long platform, a minimum of 12 inches of overlap is required unless the planks are nailed together.

Access:

- 1) Ladder, stair or other suitable access must be provided for all scaffold platforms.
- 2) Cross bracing on scaffolding must NEVER be used for climbing or access.
- 3) End frames of scaffolding may be used for ladder access and climbing provided that the space between horizontal members or rungs does not exceed 22 inches.

Scaffold Use:

- 1) Scaffolding and components must be inspected for visible defects by a Competent Person each day and after any occurrence that could affect the scaffold's structural integrity, that competent person is the Beeler Construction Superintendent. If components are found to be damaged or defective and are deemed unsafe, they must be tagged out by a Competent Person and immediately repaired or replaced or removed from the jobsite.
- 2) Scaffolds must be erected, moved, dismantled or altered only under the supervision of a Competent Person (Beeler Construction Superintendent).
- 3) Snow and ice must be removed from scaffold platforms before employees are allowed to work on the platform.
- 4) Employees must be removed from scaffolding during storms or high winds.
- 5) Debris and scrap must be routinely removed from the working sections of scaffold platforms.
- 6) Ladders or other makeshift platforms must NEVER be used on a scaffold platform.
- 7) Scaffolds are erected, used and dismantled no closer than the following distances to insulated power lines:
 - ✓ Less than 300 volts: 3 feet
 - ✓ 300 volts to 50 kv: 10 feet
 - ✓ 50 kv or greater: 10 feet plus .4 inches for each 1 kV over 50 kV

 <p>Partnerships Built on Trust</p> <p>SAFETY & HEALTH MANUAL</p>	8. Scaffolding Safety	Page 3
	Revision Date: 18/2024	Updated

Fall Protection:

- 1) Guard rails must be provided on scaffold platforms more than 10 feet above a lower level; however the use of guard rails is preferred whenever platforms are 6 feet above lower levels.
- 2) For scaffold systems manufactured after January 1st, 2000 the top edge of guard rails must be located no less than 38 inches and no more than 45 inches above the platform surface. For scaffold systems manufactured before January 1st, 2000 the top edge of guard rails must be located no less than 36 inches and no more than 45 inches above the platform surface.
- 3) Mid rails are required and must be installed at a height midway between the platform and guard rail.
- 4) The top rail must be capable of withstanding a force of 200 pounds applied in any downward or horizontal direction, the mid rail capable of withstanding a force of 150 pounds applied in any downward or horizontal direction, and a toe board capable of withstanding a force of 50 pounds in any downward or horizontal direction.
- 5) Cross bracing is acceptable in place of a top rail when the crossing point (center of the X) is between 38 and 48 inches above the work platform.
- 6) Cross bracing is acceptable in place of a mid-rail when the crossing point (center of the X) is between 20 and 30 inches above the work platform.

Falling Object Protection:

- 1) Employees that are working on or near scaffolds must wear hard hats.
- 2) Areas beneath scaffolding where employees might be struck by falling materials can be protected by barricading and isolating the areas beneath the scaffolding where they could be struck.
- 3) Toe boards must be installed on scaffold platforms to prevent tools, materials and debris from falling off the platform to areas below.

▼ Requirements for Supported Scaffolds:

- 1) Scaffolds with a height to minimum base width of more than a 4 to 1 ratio (4:1) must be restrained, braced or tied into the structure.
- 2) Bracing or ties must be at the closest horizontal member corresponding to the 4:1 height and then repeated vertically every 20 feet for scaffold platforms 3 feet wide or less and every 26 feet for scaffold platforms wider than 3 feet.
- 3) Bracing or ties must be installed at the ends of the scaffold platform and then at horizontal intervals not exceeding 30 feet between the ends for scaffolds that require bracing or ties.
- 4) Broken bricks, bricks or blocks laid on their side or other unstable debris or objects must not be used to support or level scaffold platforms.
- 5) Scaffold frames or uprights must be on base plates and mud sills or other adequate foundation.

 Partnerships Built on Trust	8. Scaffolding Safety	Page 4
	Revision Date: 18/2024	Updated

SAFETY & HEALTH MANUAL

- 6) Front end loaders or other heavy equipment must NEVER be used to support scaffolding or sections of scaffolding.

▼ Mobile or Rolling Scaffolds:

- 1) Mobile scaffolds shall be braced by cross, horizontal or diagonal braces to prevent racking or collapse of the scaffold and to keep the vertical member square and aligned.
- 2) The working platforms of rolling scaffolds must be fully planked and cleated to prevent movement.
- 3) Caster brakes must be locked when the scaffold is not being moved.
- 4) The area where rolling scaffolds are being moved must be carefully inspected for debris, holes and imperfections in the floor which could cause the scaffold to fall during movement and the surface must be within 3 degrees of level.
- 5) While manually moving the scaffold force to be applied as close to the base as possible; but not more than 5 feet above the supporting surface.
- 6) If a power system is used to move the scaffold, movement must be less than 1 foot per second.
- 7) All tools, materials and equipment must be removed from the scaffold if the scaffold is moved while employees remain on the platform.
- 8) The height of rolling scaffolds must not exceed two times the minimum base dimension, including outriggers, unless the scaffold is designed and constructed according to ANSI/SIA A92.5 and A92.6.
- 9) Outriggers, when used, must be installed on both sides of the scaffold.

▼ Other Specific Scaffolds:

- 1) Other types of scaffolding systems must comply with specific requirements contained in 29 CFR 1926.452 for scaffolds not identified above.

 Partnerships Built on Trust	9. Aerial Lift Safety	Page 1
	Revision Date: 1/8/2024	Updated
SAFETY & HEALTH MANUAL		

Aerial Lift Safety

PURPOSE: The purpose of this procedure is to provide requirements for the safe use of aerial lifts used by Beeler Construction employees and employees of subcontractors. This document is a summary of OSHA's comprehensive requirements contained in 29 CFR 1926, Subpart L concerning the use of aerial lifts.

POLICY: Beeler Construction provides a safe and healthful workplace for all of its employees. This procedure summarizes the main requirements of OSHA's comprehensive aerial lift requirements. This procedure applies to all jobsites, activities and situations where Beeler Construction employees and subcontractors use aerial lifts.

▼ Telescoping/Articulating Aerial Lifts:

- 1) Only authorized personnel are allowed to operate aerial lift equipment, employees must be trained in the specific lift use/operations prior to accessing and operating any lift.
- 2) Employees working in aerial lifts must wear a body harness and shock absorbing type lanyard.
- 3) Employees must NEVER tie off to any structure other than the bucket or structure of the lift. Tying off to structures outside of the lift is not permitted.
- 4) Employees must stay within the bucket and firmly on the floor of aerial lift work platform; employees must NEVER climb on top of the rails or edge of the basket or out of the lift onto adjacent structures.
- 5) Depending on the use and location, the above rules may or may not apply to a scissor type lift protected by an approved guard rail system.
- 6) Aerial lift equipment may not be field modified unless it is certified in writing by the manufacturer or any other equivalent entity.
- 7) Aerial lift equipment must be tested and inspected on a daily basis; inspections should be recorded in the project superintendent's daily log or in an inspection log specific to that piece of equipment.
- 8) Employees working with aerial lifts must NEVER exceed the load limits of the lift equipment.
- 9) All lift equipment should have an operational back alarm, if the lift is not equipped with such, a spotter must be used during backing operations.
- 10) Aerial lifts must be used no closer than the following distances to insulated power lines:
 - ✓ Less than 300 volts: 3 feet
 - ✓ 300 volts to 50 kV: 10 feet
 - ✓ 50 kV or greater: 10 feet plus .4 inches for each 1 kV over 50 kV

 Partnerships Built on Trust SAFETY & HEALTH MANUAL	10. Mobile Crane & Rigging Safety	Page 1
	Revision Date: 1/8/2024	Updated

Mobile Crane & Rigging Safety

PURPOSE: The purpose of this policy is to protect all workers from injury and to prevent property damage resulting from mobile crane operations. This document is a summary of OSHA's requirements contained in 29 CFR 1926.1400, Subpart CC-Crane and Derricks in Construction.

POLICY: Beeler Construction provides a safe and healthful workplace for all of its employees. This policy applies to the use of all mobile cranes, including those used by our subcontractors and their subcontractors. All safety procedures, inspection and training requirements identified in this policy as well as the OSHA Crane and Derrick standard, apply for all crane operations taking place on Beeler Construction jobsites.

The Mobile Crane Lift Plan worksheet located at the end of this section must be completed prior to any lifts taking place that involve long lead time materials or equipment, expensive materials of equipment, etc. Completion of the worksheet is not required for routine lifts involving tools or debris removal.

All subcontractors using cranes on Beeler Construction jobsites must submit their Mobile Crane Safety policy to Beeler Construction for review prior to any crane operations.

TRAINING: All Beeler Construction employees shall receive initial mobile crane safety training and annual refresher training. The purpose of the training is to continue Beeler Construction's commitment to providing a safe and healthy work environment by ensuring awareness of the risks involved with craning/hoisting of materials and equipment.

RESPONSIBILITIES:

▼ Competent Person:

Beeler Construction's on site supervisor will be designated as Competent Person on jobsites where crane operators are contracted directly by Beeler Construction. When subcontractors are including crane operations as part of their subcontract with Beeler Construction, the subcontractor must designate a Competent Person that is responsible for addressing key hazards associated with equipment use, assemble and disassembly. The competent person has the authority and may refuse a lift at any time if there is a concern for safety. In such a case, lifting procedures will commence only after the competent person has determined that safety has been assured.

 Partnerships Built on Trust SAFETY & HEALTH MANUAL	10. Mobile Crane & Rigging Safety	Page 2
	Revision Date: 1/8/2024	Updated

▼ Operators

Only employees qualified by training and experience shall be allowed to operate craning equipment and machinery. All operators SHALL be qualified and/or certified by one of the following methods:

- 1) Certification by an accredited crane operator testing organization
- 2) Qualified by an audited employer program
- 3) Qualifications by the US military
- 4) Licensing by a government entity

Operators may at any time refuse the lift anytime there is a safety concern.

PROCEDURES:

- 1) The manufacturer's procedures, specifications and instructions/operator's manual MUST be followed at all times during assembly and disassembly and during crane operations, NO EXCEPTIONS. The competent person must oversee all assembly and disassembly of equipment. The crane operator's manual MUST be readily available in the cab of the crane at all times.
- 2) Subcontractor shall provide the following documentation before starting work:
 - ✓ Current subcontract agreement (signed) and certificate of insurance
 - ✓ Copy of annual crane safety inspection
 - ✓ Copy of qualified riggers and qualified signal person training documentation
 - ✓ Copy of most recent monthly crane inspection and monthly rigging equipment inspection
 - ✓ Copy of the crane operator's NCCCO certification, or equivalent alternative identified in OSHA 1926.1400
 - ✓ Completed Mobile Crane Lift Plan worksheet-attached
 - Page one submitted before arriving on site
 - Page two completed on site before the initial lift

Subcontractors requiring the use of their own Lift Plan worksheet form is an acceptable alternative to Beeler Construction's form, as long as the form is similar and comparable. However, the requirements established within this policy, including the maximum lifting capacities still apply when using the general contractor's Lift Plan worksheet.
- 3) The subcontractor shall designate an Assembly/Disassembly (A/D) Director, (competent and qualified person) that is responsible for addressing key hazards associated with equipment assembly and disassembly.
- 4) The competent person confirms the adequacy of ground conditions prior to set-up. The crane shall not be assembled or used unless the ground conditions are firm, drained and graded sufficiently, so that in conjunction with supporting materials, are within the crane manufacturer's specifications. Meet with the controlling entity, when appropriate, to confirm adequate ground connections and identify location of any hazards underneath the set-up such as manholes, voids, tanks, utilities, backfill, etc.



Partnerships
Built on Trust

SAFETY & HEALTH MANUAL

10. Mobile Crane & Rigging Safety

Page
3

Revision Date: 1/8/2024

Updated

- 5) The competent person completes a visual inspection of the crane and the wire rope, slings and rigging equipment after crane assembly and before each shift. The competent person should also conduct daily inspection of equipment and record such inspections.
- 6) The competent person completes a documented monthly crane inspection and documented monthly rigging equipment inspection.
- 7) An annual comprehensive equipment inspection is completed by a qualified person.
- 8) Only qualified signal persons are used. Each signal person must be trained in both hand and voice signals and shall meet with the crane operator prior to beginning operations. Signal persons must be used whenever the operator's view is obstructed.
- 9) All rigging work is done by a qualified rigger. All rigging work includes, but not limited to, rigging used in assembly/disassembly operations and rigging work within the fall zone.
- 10) Complete a site assessment of the crane's work zone to determine if any part of the crane, load line or load is capable of coming within **20 feet** of energized power lines rated up to 350kV. The work zone is defined as 360 degrees around the crane up to the crane's maximum working radius. When the 20 foot work zone is breached, the preferred method is to de-energize and visibly ground the lines at the work site. When de-energization is not feasible, then submit a safety pre-plan describing your methods to control the hazard.
- 11) Verify load weight by contacting the equipment manufacturer.
- 12) The lift shall not exceed **85%** (for outriggers) and **75%** (on tires) of the maximum rated capacity at the longest lift radius.
- 13) Use blocking/matting in accordance with the crane manufacturer's specifications. The crane capacity (tons) divided by 5 equals the minimum blocking area per pad (sq.ft.).
- 14) Crane is level within crane manufacturer's guidelines. Most load chart ratings require the crane to be perfectly level or within 1% grade (0.57 degrees).
- 15) No crane picks are allowed with wind speeds greater than or equal to **20 mph**. Crane picks shall be suspended until wind and weather conditions are acceptable. Note: some cranes have a load chart for winds greater than **20 mph**. Approval to continue to operate must be provided by Beeler's client and Beeler's safety department before crane operations can resume.
- 16) Use non-conductive tag lines. When working around electrical line always use an insulating tagline link.



 SAFETY & HEALTH MANUAL	Partnerships Built on Trust	10. Mobile Crane & Rigging Safety	Page 4
		Revision Date: 1/8/2024	Updated

- 17) If any modifications of equipment are required, such modifications **MUST** be approved by the equipment manufacturer or by a licensed Professional Engineer before any equipment changes can be made. Equipment manufacturers must approve changes in writing and the Professional Engineer must be qualified/experienced with respect to the equipment involved and must ensure the original safety factor of the equipment is not reduced.
- 18) The crane's swing radius must be marked and/or barricaded at all times during use to avoid any struck by or pinch/crush injuries.

These requirements are in addition to already established federal standards and other recognized safety standards.

RIGGING:

▼ Description:

When workers prepare equipment to be lifted by cranes, hoists or other material-handling machinery, rigging is a common work process on shipyard and construction sites, among others. Performing rigging operations safely is critical. According to OSHA, rigging workers have been injured or killed when loads have slipped or the rigging has failed.

▼ Requirements:

All riggers must be:

- 1) Properly trained on the hazards associated with rigging jobs and must be certified by an authorized training agency.
- 2) Qualified and able to comply with all procedures.
- 3) Aware of where the crane is operating (surface should be level and firm enough to support the crane and load).
- 4) Familiar with rigging techniques and equipment.
- 5) Able to anticipate issues before they happen.
- 6) Able to stop a job immediately if unsafe conditions exist.
- 7) Aware of the weight of the load and the capacities of the crane and any rigging gear, rigging must never be used beyond its rated working capacities.

▼ Helpful Tips:

- 1) Riggers should keep their hands, fingers and feet clear of pinch points.
- 2) Be aware of stacked material when lifting to avoid knocking it over with a swinging load.
- 3) Always be aware of the load lift and stay clear from suspended loads.
- 4) Use a designated spotter during lifting to ensure proper clearances are maintained.
- 5) Check for overhead power lines before lifting a load.
- 6) Warn nearby workers before raising, lowering or swinging a load.

 Partnerships Built on Trust	10. Mobile Crane & Rigging Safety	Page 5
	Revision Date: 1/8/2024	Updated
SAFETY & HEALTH MANUAL		

- 7) When setting a load down, check that the landing area is clear and set it down slowly.
- 8) Riggers must inspect equipment before use; if equipment is damaged, it must immediately be repaired, removed and discarded or replaced.
- 9) Tag lines shall be used unless they are determined to create an unsafe condition.
- 10) Tag lines are used to stabilize loads, they help keep loads from swinging or swaying and coming in contact with electrical lines and prevent collisions. No Tag lines are completely non-conductive. To avoid transmittal of electrical in the event of accidental contact with power lines, use a rated insulating tagline link.
- 11) All rigging hooks must include safety latches; latches must be inspected for proper use before each lift.
- 12) When not in use, all rigging equipment shall be removed from the work area.

▼ Signal Person

The signal person must have proven knowledge of both proper crane operation and signaling procedures and be capable of safely and efficiently directing the crane operator in controlling the crane's movements. While the person performing the job need not possess the physical skills of a crane operator, they must be; trained, evaluated, qualified and understand safe operations of a crane. In addition to the standard crane hand signals, the signal person must know which manipulations a crane can perform safely and which can cause damage or injure fellow workers. If the crane operator is requesting/signaling a maneuver that is unsafe the signal person should refuse it. In many instances the crane operator's view is limited and he/she must rely on the signal person to signal the appropriate crane maneuvers to assure the safety of the lift. When the signal person is knowledgeable and conscientious enough not to request dangerous or unsafe maneuvers a double check of safety is achieved between he/she and the crane operator.

▼ Requirements:

A signal person must be provided in the following situations:

- 1) Whenever the pint of operation, meaning the load of travel or near or at the load placement, is not in full view of the operator.
- 2) When the equipment is traveling and the view in the direction of travel is obstructed.
- 3) Whenever it is determined the necessary due to specific site safety concerns

▼ Qualifications:

Only a qualified signal person is allowed to communicate signals to a crane operator. When required, this person must be provided by the on-site Contractor or Subcontractor directly responsible or contracted to perform the lift. Each signal person must meet the following qualifications in accordance with OSHA 1926.1428 and must demonstrate these qualifications in though passing a written and practical exam. This exam may be provided through a third party qualified evaluator or an employer qualified evaluator, documentation for whichever option is used must be maintained by the employer during



Partnerships
Built on Trust

SAFETY & HEALTH MANUAL

10. Mobile Crane & Rigging Safety

Page
6

Revision Date: 1/8/2024

Updated

the duration of employment of the signal person. If the exam is conducted by an employer evaluator, the training is not to be considered portable, meaning it does not apply to other employees and only applies to the employee that has been trained.

Qualifications for a competent crane signal person are as follows:

- 1) Know the Standard Crane Hand Signal from memory.
- 2) Be competent in the application of the type of signal used.
- 3) Have a basic understanding of equipment operation and limitations, including the crane dynamics involved in swinging and stopping loads and boom deflection from hoisting loads.
- 4) Act as the crane operator's eyes in observing possible dangers.
- 5) Signal the desired load or hook movements based on his/her direct observation and evaluation of site conditions.
- 6) Ensure that each load is securely rigged with the hook block over the load CG before signaling the crane to lift.
- 7) Inspect and maintain rigging hardware and equipment.
- 8) Ensure correct rigging configurations and capacities.
- 9) Monitor all parts of the crane, rigging and load to ensure necessary clearances to obstructions are maintained.
- 10) Work with the operator to evaluate the safety and efficiency of anticipated maneuvers.

Mobile Crane

Hand Signals

Copyright ©2005, ACRA Enterprises, Inc.

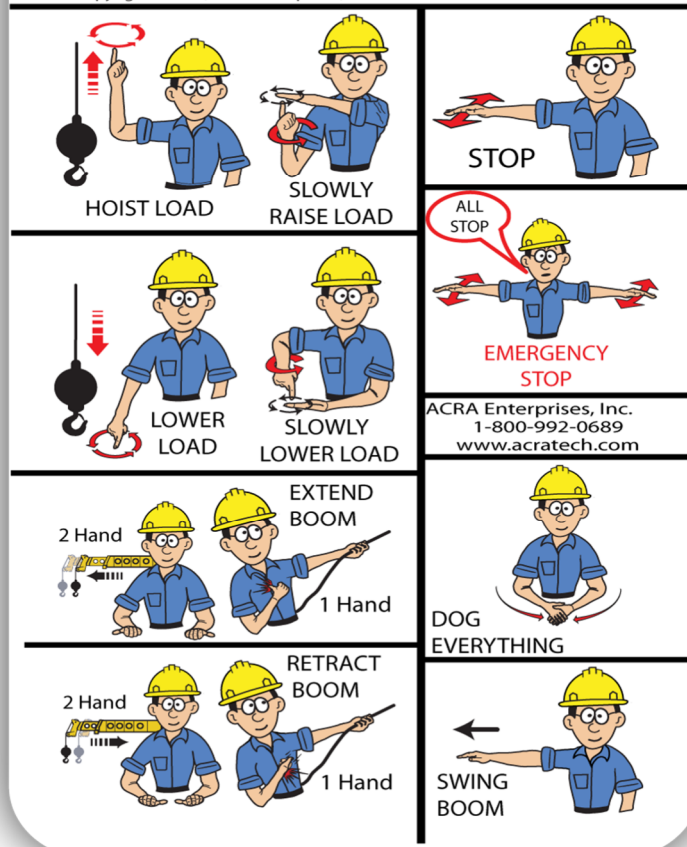



Partnerships
Built on Trust

SAFETY & HEALTH MANUAL

**10. Mobile Crane &
Rigging Safety**

**Page
7**

Revision Date: 1/8/2024

Updated

**BEELER CONSTRUCTION, INC.
MOBILE CRANE LIFT PLAN WORKSHEET**

Project Information	
Date:	Job Number:
Project:	
Jobsite Address:	
Description of lift to be performed:	
Lift Plan Prepared by:	Pick Date:
Lift Plan Drawing & Load Placement Drawing Attached?	<input type="checkbox"/> Yes <input type="checkbox"/> No
Crane Information	Lift Information
Manufacturer:	Weight of the load: lbs
Model:	Allowance for extra weight: lbs (scale, sludge, internals, liquid, etc.)
Serial #:	
Crane Rating:	Weight of rigging: lbs
Crane Inspection Date:	Weight of block: lbs
Notes:	Weight of head ache ball: lbs
	Weight of spreader: lbs
Rigging Components	Weight of jib: lbs
Sling Type: <input type="checkbox"/> Wire Rope <input type="checkbox"/> Synthetic Web	Jib erected: <input type="checkbox"/> Yes <input type="checkbox"/> No
<input type="checkbox"/> Synthetic Round <input type="checkbox"/> Alloy Chain	Weight of hoist line lbs
Sling Size:	Weight of attachments lbs
Length:	Auxiliary boom head lbs
Capacity:	TOTAL WEIGHT LIFTED lbs
Angles:	
Shackle Size:	Hoisting from: <input type="checkbox"/> Main Boom <input type="checkbox"/> Fly
Shackle Capacity:	<input type="checkbox"/> Extension <input type="checkbox"/> Jib
Rigging Diagram	Maximum radius to be used: ft
	Boom length: ft
	Boom angle: degrees
	Jib offset:
	On outriggers: <input type="checkbox"/> Yes <input type="checkbox"/> No
	On tires: <input type="checkbox"/> Yes <input type="checkbox"/> No
	Parts of line:
	Counterweight: lbs
	Estimated clearance between boom and surrounding utilities: ft
	Below ground hazards have been identified and located: <input type="checkbox"/> Yes <input type="checkbox"/> No
Set-up Information	Will the crane be traveling with a load? <input type="checkbox"/> Yes <input type="checkbox"/> No
Crane Set-up: <input type="checkbox"/> Over Rear <input type="checkbox"/> 360°	What is the maximum crane slope or angle the crane can travel on: degrees
<input type="checkbox"/> Over Front <input type="checkbox"/> Over Side	
Set-up distance:	CAPACITY FROM CHART lbs
Mat used: <input type="checkbox"/> Yes <input type="checkbox"/> No	% OF CAPACITY
Mat dimensions: (min. matting area (sq.ft.) = crane capacity (tons) ÷ 5	(see example below)
Ground bearing pressure below first mat: (backfill, manholes, utilities, voids, slopes, etc.)	Example: Total weight to be lifted ÷ rated capacity of load chart x 100 = % capacity



Partnerships
Built on Trust

SAFETY & HEALTH MANUAL

**10. Mobile Crane &
Rigging Safety**

**Page
8**

Revision Date: 1/8/2024

Updated

Project:		Date:
Description of Lift:		
Site Conditions		
Underground hazards present? (backfill, manholes, utilities, voids, slopes, etc.)	€ Yes € No	If yes, explain:
Overhead hazards present?	€ Yes € No	If yes, explain:
Electrical hazards within 20 FT of crane's work zone?	€ Yes € No	If yes, explain:
Surrounding obstacles present?	€ Yes € No	If yes, explain:
Fire and explosive hazards present?	€ Yes € No	If yes, explain:
Weather conditions acceptable?	€ Yes € No	If no, explain:
Wind speed acceptable? (< 20 mph)	€ Yes € No	Speed:
Other special considerations:		
Pre-Lift Checklist		
Crane Operator:	Name:	
Rigger:	Name:	
Signal Person:	Name:	
Communication Method:		
Crane Inspected by Operator?	€ Yes € No	
Rigging Inspected?	€ Yes € No	
Crane level to manufacturer's guidelines?	€ Yes € No	
Outriggers fully extended?	€ Yes € No	
Matting set up properly? (min. matting area (sq.ft.) = crane capacity (tons) ÷ 5)	€ Yes € No	
Barricading swing radius?	€ Yes € No	
Non-conductive taglines used?	€ Yes € No	
A pre-lift meeting held and plan discussed between Crane Operator, Signal Person, Supervisor and any and all other persons prior to start of lift?	€ Yes € No	
Other special considerations:		

Signatures	
Crane Operator Name:	(print)
Signature:	Date:
A/D Director Name: (competent and qualified person)	(print)
Signature	Date:

 Partnerships Built on Trust SAFETY & HEALTH MANUAL	11. Fall Protection	Page 1
	Revision Date: 1/8/2024	Updated

Fall Protection

General Requirement for Fall Protection

Purpose

The purpose of this document is to provide guidelines and requirements to be used in performance of work that could result in a fall, and to protect and safeguard the public and employees as well as to prevent property damage.

Scope

This section applies to all Beeler Construction projects.

Policies

General Requirements

A plan must be developed at each Beeler Construction project to ensure that each employee who is exposed to a fall hazard of six feet or more is protected at all times in the course of work. This policy applies to any employee on a Beeler Construction work site including employees of all subcontractors of any tier. **Training for fall protection shall be conducted throughout the year via toolbox talks, safety meetings, and as needed for site specific situations.** The sequence of fall protection shall be:

First, elimination of the fall hazard: Change procedures and pre-plan to eliminate any fall hazard.

Second, prevention of the fall hazard: Use guardrails/barriers to keep employees away from the exposure(s).

Third, control of the fall hazard: Use personal fall arrest systems (PFAS).

Fall hazards on construction projects include:

- open sided floors
- hoist areas
- formwork and reinforcing steel work
- excavations
- overhand bricklaying
- leading edge work
- holes
- roofing work
- ramps, runways, and walkways that have a fall exposure over six feet
- dangerous equipment (if an employee is working above dangerous equipment and is exposed to a fall hazard, then the employee must be protected against fall at all times)
- wall openings
- any other exposure or condition that subjects any individual to a fall of six feet or greater

 Partnerships Built on Trust SAFETY & HEALTH MANUAL	11. Fall Protection	Page 2
	Revision Date: 1/8/2024	Updated

The only exception to this policy is when an employee or subcontractor can demonstrate that it is not feasible to provide fall protection. In such case, the employer shall develop a written fall protection plan for that situation. This is only to be used for those individuals on the crew that are exposed to the greater hazard and it must be approved, before implemented into use, by the company's management.

Any employee, Beeler Construction or other, who disregards this policy, is subject to the following disciplinary action:

First warning is given during the employee's initial training or orientation.

Second warning

- two-day suspension without pay for Beeler Construction team members
- two-day removal from the project for any subcontractor employees

Note: Upon return and before performing any additional work, the subcontractor employee and the employee's supervisor (foreman or superintendent) must attend a fall protection re-orientation.

Third Warning

- A Beeler Construction team member's employment is terminated. The Beeler Construction team member is not eligible for rehire for 365 calendar days.
- A subcontractor employee is permanently removed from the project.

Protection from Falling Objects

All individuals on an active Beeler Construction site must wear a hard hat. Individuals must also be protected against falling objects by at least one of the following:

- a guardrail system, including toe boards (at a minimum) and screens to protect against objects falling from above, between or through the guardrail system.
- a canopy structure
- a barricade on lower levels, or a controlled access zone to protect workers from entering an area where objects could fall

 SAFETY & HEALTH MANUAL	Partnerships Built on Trust	11. Fall Protection	Page 3
		Revision Date: 1/8/2024	Updated

Standards, Instructions, and Examples

Following are definitions of terms used in this section:

Low slope roof: A slope less than or equal to 4:12 (vertical to horizontal).

Personal fall arrest system (PFAS): A system used to arrest an employee's fall from a working level. It consists of an anchorage, connector(s), a body harness and may include a lanyard, deceleration device, lifeline, or a combination of these.

Positioning device system: A body harness system rigged to allow an employee to be supported on an elevated surface (wall) and work with both hands free while leaning.

Snap hook: A connector comprised of a hook-shaped body with a normally closed gate that may be opened to permit the hook to receive an object and released, automatically to retain the object.

Warning line system: A barrier erected on a roof to warn employees of an unprotected edge. It must be a minimum six feet back from an edge for roofing work, and 15 feet back from the edge for all other trades.

Personal Fall Arrest Systems

Purpose

The purpose of this section is to provide guidance on personal fall arrest systems used in performing work on Beeler Construction projects.

Scope

This section applies to all Beeler Construction projects.

Policies

A detailed plan must be developed to ensure that each employee who is exposed to a fall hazard of six feet or more is protected. The personal fall protection plan shall include:

- Requirements
- Equipment
- Personal fall arrest systems (PFAS)
- Self-retracting lifelines
- positioning devices

 Partnerships Built on Trust SAFETY & HEALTH MANUAL	11. Fall Protection	Page 4
	Revision Date: 1/8/2024	Updated

Equipment

Only approved full-body harnesses, supplied by each employer for their own employees, may be worn.

- The maximum force that a body harness can put on an employee during a fall is 1800 pounds (8 kN).
- All connectors must have a minimum tensile strength of 5,000 pounds (22.2 kN).
- Only double-locking-type snap hooks may be used and they must be sized to be compatible with the individual and structural member to which they are connected.
- All snap hooks or carabiners shall be capable of withstanding a load of, at a minimum, 3,600 pounds (16 kN) in all directions including gate strength.
- Shock absorbing lanyards and lifelines must have a minimum breaking strength of 5,000 pounds (22.2 kN).
- The D-ring on the body harness for connection to the fall arrest system must be located in the center of the wearer's back, near shoulder level. A front D-ring for certain applications must be located in the center of the chest.
- None of the components of the fall arrest system (harnesses, lifelines, lanyards, etc.) may be used for any purpose other than fall arrest, with the exception of the side D-rings, which may be used for positioning.
- All components of a personal fall arrest system that have been subjected to a fall (impact loading) must be removed from service, tagged as inoperable and sent to either the equipment facility or manufacturer for repair prior to re-use, or simply destroyed.
- All components of the PFAS must be inspected daily before use.
- All lifelines, vertical and horizontal, must be protected from cuts, burns, and abrasions. Inspect prior to each usage.
- Do not connect two snap hooks together under any circumstances. Snap hooks are to be connected to the D-ring. For example, a six-foot lanyard that is connected to the back D-ring of the body harness may not be connected to the snap hook of a self-retracting lifeline (SRL).

Fall Arrest System Requirements

- Anchorage points may not be used for purposes other than those intended and must be capable of supporting a minimum of 5,000 pounds (22.2 kN) per individual attached.
- The fall arrest system must be designed and inspected by a qualified person. Only one employee may use each vertical lifeline.
- Whenever possible, only one employee should be tied off to a horizontal lifeline.
- If this is not practical, then the system must be designed to be able to support 5,000 pounds, times the number of employees using it (e.g., three employees' x 5,000 pounds = 15,000 pounds).
- Personal fall arrest systems must be designed to limit the free-fall distance to less than six feet (1.83 m) before the expansion of the lanyard and must prevent contact with a lower level.
- Rescue procedures must be planned prior to the commencement of work. The rescue procedures must be specified in the fall protection plan.

 Partnerships Built on Trust	11. Fall Protection	Page 5
	Revision Date: 1/8/2024	Updated
SAFETY & HEALTH MANUAL		

- Only lanyards with energy absorption may be used as part of the PFAS.

Self-Retracting Lifelines (SRLs)

- SRLs must have a minimum tensile strength of 3,000 pounds (13.3 kN). All manufacturers' recommendations must be followed.
- All SRLs, when not in use, are to be retracted so that all of the line is situated inside of the housing. A tether is to be attached to the end of the snap hook for access to the SRL.

Positioning Device Systems

- Positioning device systems must limit fall distance to two feet (0.61 m) or less. Anchorage points must be capable of supporting 3,000 pounds (13.3 kN).
- Positioning device systems must be used in addition to a PFAS, either energy absorbing lanyard or SRL, when there is a fall potential of six feet or greater.

Cable and Rope Grabs (Vertical Climbing)

- Cable and rope grabs used as part of a personal fall arrest system must be connected to the chest D-ring of the harness when climbing in a vertical direction.
- Cable and rope grabs must be sized for the appropriate rope or cable, typically a 5/8-inch rope and an eight millimeter or 3/8-inch cable.
- Tie-off must be maintained at all times when transferring on or off a vertical climbing rope or cable; that is, a double lanyard or a Y-lanyard may be required.
- The attachment distance between the vertical cable or rope to the chest D-ring shall not exceed 9 inches and shall be a direct connection with no breakaway lanyard as part of the climbing system.

When using rope for climbing vertically:

- Spliced eyes in laid ropes having three or more strands shall have a minimum of four tucks.
- A properly sized thimble shall be part of the formed eye termination.
- Knots shall not be used for load-bearing end terminations.
- Formed eye terminations shall have a minimum breaking strength of 90 percent of the synthetic rope, and the synthetic rope used in vertical lifelines shall have a minimum breaking strength of 5,600 pounds (25 kN).

When using cable for climbing vertically it must be able to support 5,000 pounds for each climber.

For one climber, the cable must support 5,000 pounds; for two climbers, it must support 10,000 pounds, and so on.

- U-bolts used to attach the cable must be torqued to the appropriate foot-pounds specifications for the diameter of the cable, and the cable must have the appropriate turn back distance.
- For climbing cable, a minimum of three volts must be used, where the saddle of the U-bolt is placed on the lad side of the cable. U-bolts should never be staggered.

 Partnerships Built on Trust	11. Fall Protection	Page 6
	SAFETY & HEALTH MANUAL	Revision Date: 12/23/2022

Standards, Instructions and Examples

Following are illustrations of personal fall protection equipment:



Carabiner



Snap hook



Double-leg shock-absorbing lanyard



Self-retracting life



Partnerships
Built on Trust

SAFETY & HEALTH MANUAL

11. Fall Protection

Page
7

Revision Date:
12/23/2022

Updated:



Roof anchorage system



Partnerships
Built on Trust

SAFETY & HEALTH MANUAL

11. Fall Protection

Page
8

Revision Date:
12/23/2022

Updated:



Full body harness with shock-absorbing lanyard



Beamer – overhead anchorage point



SRL and D-ring extender

 <p>Partnerships Built on Trust</p> <p>SAFETY & HEALTH MANUAL</p>	<p>11. Fall Protection</p>	<p>Page 9</p>
	<p>Revision Date: 12/23/2022</p>	<p>Updated:</p>



Horizontal Life Line



Rope grab vertical fall protection system

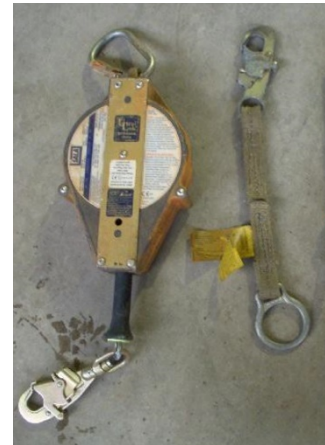

Pre-manufactured vertical climbing rope

 Partnerships Built on Trust SAFETY & HEALTH MANUAL	11. Fall Protection	Page 10
	Revision Date: 12/23/2022	Updated:

Guardrails

Purpose

The purpose of this section is to provide guidance on guardrail systems, their components, installation, and requirements, when used in performing work on Beeler Construction projects.

Scope

This section applies to all Beeler Construction projects.

Policies

Guardrail systems are installed to prevent accidental exposure to physical hazards such as moving machinery, live electrical parts, and floor or wall holes or openings. All unprotected edges (for example, floor holes, roofs, open-sided floors or decks) must be surrounded with guardrails to prevent individuals from being exposed to a fall hazard of greater than six feet.

Guardrails must not be used as a tie-off anchorage unless they meet the 5,000 pounds per employee requirement and are designed by a licensed, professional engineer as tie-off anchorages. A guardrail used as a tie-off anchorage must be designed and clearly marked indicating the tie-off capabilities (e.g., supports two people, etc.).

General Requirements

A standard guardrail system must consist of:

- top rail
- mid-rail
- upright supports or posts
- toe board

Top Rails, Mid-rails and Toe Boards

The components of the guardrail system must be free from sharp edges, splinters or similar conditions that may cause injury.

The posts or uprights must be a two inch by four-inch board long enough to support the top rail at its proper height. They must not be spaced more than eight feet apart.

Iron pipe may be used for the upright supports or posts as long as it is at least 1- 1/2 inch in outside diameter (ANSI Schedule 40) and brackets are used on the pipe to support the rails at the proper heights, spaced not more than eight feet on center.

Posts, top rails, and immediate rails, for all structural railings, must be at least two inches by two inches by 3/8-inch angles, with posts not spaced more than eight feet on center.

 Partnerships Built on Trust SAFETY & HEALTH MANUAL	11. Fall Protection	Page 11
	Revision Date: 12/23/2022	Updated:

Top rails must meet the following criteria:

- height of 42 inches, plus or minus three inches, measured from the floor or platform to the upper surface of the top rail
- if using lumber, a minimum of two-inch by four-inch board (standard 2 x 4)
- if using cable, at least 1/2-inch cable or 3/8-inch-high strength cable. This cable must be flagged every six feet for visibility purposes.

When necessary, snow fence, netting, steel mesh, or plywood may be used in conjunction with the toe board and mid-rail as falling object protection.

The mid-rail must be a minimum of two-inch by four-inch board mounted midway (21 inches, plus or minus three inches) between the floor or platform and the underside of the top rail.

The toe board shall be a minimum of one inch by four-inch board mounted horizontally at the level of the floor or platform.

Strength Requirements

The top rail of the guardrail system must be capable of withstanding, without failure, a force of at least 200 pounds;

- applied in any direction
- at any point on the top edge
- in any downward or outward direction with deflection of less than three inches

All mid-rails, screens, mesh, solid panels, and equivalent structural members must be able to withstand, without failure, a force of at least 150 pounds applied in any downward or outward direction.

Installation Requirements

During the installation of guardrail systems, employees exposed to any fall hazard must be protected by use of PFAS that meet the criteria laid out in the previous section of Personal Fall Arrest Protection.

The guardrail system must be installed under the direction of a competent person.

When material is piled above a standard toe board, paneling or screening from floor to mid-rail or to top rail must be used.

When guardrails are used around floor holes used for passage of materials, the hole must have a minimum of two non-removable guardrails. The floor hole must be covered or completely protected when not in use.

 <p data-bbox="553 142 691 184">Partnerships Built on Trust</p>	<p data-bbox="862 79 1227 121">11. Fall Protection</p>	<p data-bbox="1369 86 1463 174">Page 12</p>
<p data-bbox="215 228 805 270">SAFETY & HEALTH MANUAL</p>	<p data-bbox="862 243 1122 327">Revision Date: 12/23/2022</p>	<p data-bbox="1338 228 1479 260">Updated:</p>

When guardrails are used around floor holes that are used as a point of access (e.g., ladders, etc.), they must be in the form of a spring-loaded gate.

 SAFETY & HEALTH MANUAL	Partnerships Built on Trust	11. Fall Protection	Page 13
		Revision Date: 12/23/2022	Updated:

When guardrail systems are used at hoisting areas, a removable guardrail system must be placed across the access opening when hoisting operations are not taking place. Note: A clearly marked fall-arrest system must be used when employees are exposed to a fall of greater than six feet, for instance when grabbing the load.

Guardrail components removed or taken down must be replaced immediately by the same party, or Beeler Construction reserves the right to and may re-install them and charge back that party.

All temporary floor openings shall have one of the following:

- a permanent guardrail system
- a temporary guardrail system that meets the installation requirements, above, for guardrails
- a floor hole cover installed

Hole covers shall be:

- secured to protect against accidental displacement with nails, fasteners, etc.
- clearly identified as a hole cover using the words, "Hole", "Cover", or other written warning
- able to support at least twice the intended load of people, equipment, etc.

Cable Guardrails

- All cables must be at least 1/2-inch diameter or equivalent.

Note: A smaller size cable maybe used. This is a best practice, by installing a larger size cable, it may reduce the possibility of the cable failing.

- Two cables must be used.
- One serves as a top rail mounted 42 inches above the walking surface.
- One serves as a mid-rail, installed halfway between the floor and top rail height.

Exception: During structural steel erection, an ironworker may use one cable.

- Toe boards must be installed.
- Splices in the cables can only be made by looping both ends and joining the loops.
- A minimum of three drop-forged cable clamps, properly tightened, are required on all cable ends. Follow the manufactures recommendations for installation.
- Cables must be tensioned to allow minimal deflection (approximately two inches per 30-foot span).
- Cable shall be flagged ever six feet. Example: using red duct tape (works the best).

 Partnerships Built on Trust	11. Fall Protection	Page 14
	Revision Date: 12/23/2022	Updated:

SAFETY & HEALTH MANUAL

Anchorage of Cable Systems

Cable anchoring means fastening the cable end firmly to a strong support.

Cable support means suspending or holding the cable to the correct height next to a column. This is not an anchor point.

Cable system anchorage requirements are as follows:

- Cables should be mounted on the inside faces of the columns or through the column when the column is designed in such a manner.
- One method for anchoring a cable to any type of column is by wrapping the cable around the column and clamping the cable back to itself using three drop- forged cable clamps.
- The cable must be strung so that it is anchored in straight lines. Do not string cables continuously around corners of any angle unless the corner is an anchor point.
- Cables can be supported on a column by using forged eyebolts or anchors, lumber drilled and secured to the column, or by two welded washers and nuts. Warning: Cables can be supported by these methods but not anchored.
- Rebar must not be used as posts, rails, or any other component of a cable Guardrail system.
- Only cable in good condition may be used. Periodic inspection of cables must be conducted. Defective cables or components must be replaced.
- Cables are for personal safety only. Air hoses, cords, tarps, welding leads, etc., must never be supported by these perimeter cables.
- The cable must be flagged every six feet for visibility.
- If the cable is to be utilized for tie-off, it should be designed by a licensed, professional engineer. Signage posted conspicuously on the cabling must indicate tie-off requirements.

 Partnerships Built on Trust SAFETY & HEALTH MANUAL	11. Fall Protection	Page 15
	Revision Date: 12/23/2022	Updated:

Standard, Instructions and Examples

The following leads to the best practices for guardrail systems for precast buildings:

Best Practice, Guardrail System for Precast Buildings

The following are illustrations of the use of guardrails for fall protection:



Wooden Guardrail



Perimeter wire rope guardrail and toe board with flagging every 6'



Partnerships
Built on Trust

SAFETY & HEALTH MANUAL

11. Fall Protection

Page
16

Revision Date:
12/23/2022

Updated:

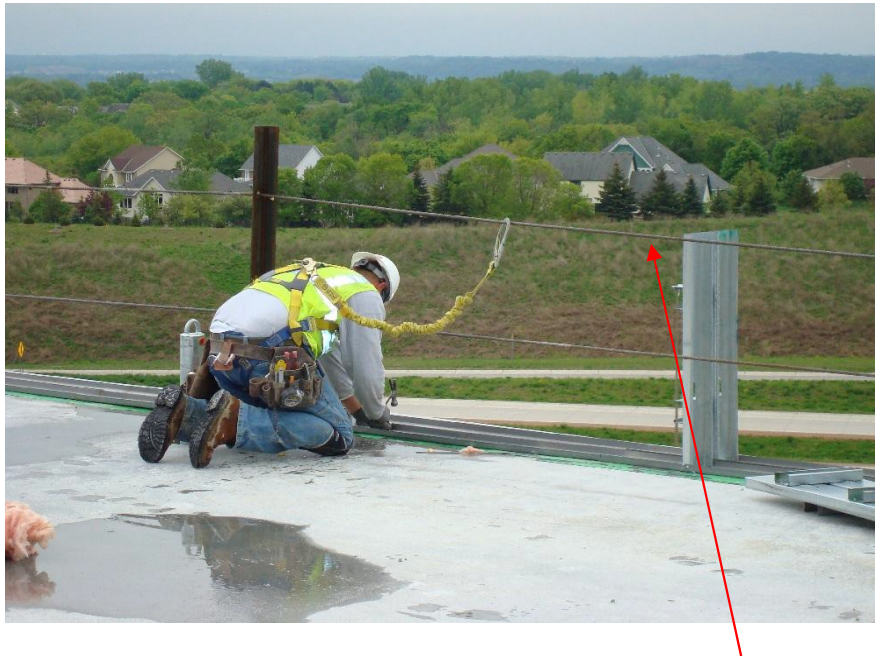

Perimeter guardrail system with engineered fall protection for top rail, missing flagging every six feet

Floor Perimeter and Leading Edge Work

Purpose

The purpose of this section is to provide guidance for protecting all individuals while working in and around floor perimeters and leading edges.

Scope

This section applies to all Beeler Construction projects.

Policies

Whenever there is the potential for a fall of six feet or more, the perimeter must be protected by a minimum of a standard guardrail. (See Guardrails Section.)

When conducting leading edge work six feet or more above any lower level, a fall protection system must be used. The only exception is when an employer can demonstrate a greater and more probable hazard exists. In such an instance, the employer shall develop and implement a written specialized, project-specific fall protection plan. This plan may only be used for those individuals identified on the crew that are exposed to the greater hazard.

 <p>Partnerships Built on Trust</p> <p>SAFETY & HEALTH MANUAL</p>	<p>11. Fall Protection</p>	<p>Page 17</p>
	<p>Revision Date: 12/23/2022</p>	<p>Updated:</p>

Any employee who works outside of the perimeter guardrail system must be tied off with an approved fall protection as specified in Personal Fall Arrest Systems Section.



Partnerships
Built on Trust

SAFETY & HEALTH MANUAL

11. Fall Protection

Page
18

Revision Date:
12/23/2022

Updated:

Excavations

Each employee at the edge of any excavation six feet or more in depth must be protected from falling into the excavation by:

- a guardrail system
- fencing
- barricade(s)
- PFAS
- proper access, such as a ladder, steps, or a slope

Roofing

See Roofing Section for further guidance.

Duct, Elevator, Stairway, and Skylight Openings

All duct, elevator, stairway (during installation or until treads are either poured or temped in), or mechanical shaft openings must be protected from falling materials and fall exposures by at least one or a combination of the following:

- a guardrail system
- fencing
- barricades
- plywood
- PFAS

Standards, Instructions, and Examples

Following are illustrations of fall protection for floor perimeter and leading edge work:



Floor perimeter guardrail system



Partnerships
Built on Trust

11. Fall Protection

Page
19

SAFETY & HEALTH MANUAL

Revision Date:
12/23/2022

Updated:



Floor opening with Guardrails and mesh



Floor hole cover- Marked hole

 Partnerships Built on Trust	11. Fall Protection	Page 20
	Revision Date: 12/23/2022	Updated:

SAFETY & HEALTH MANUAL

Roofing Work

Purpose

The purpose of this document is to provide guidance on fall protection during the performance of roofing work.

Scope

This section applies to all Beeler Construction projects.

Policies

Guidelines

Employees working on roofs must be protected from the hazards of falling at all times. On low-pitch roofs (where pitch is 4 to 12 or less) employees must be protected by the use of one or more of the following methods:

- 1) Elimination of the fall hazard (e.g. scaffold the perimeter of the roof, etc.)
- 2) Warning lines: Rope, wire, or chain and vertical supports, erected on flat roofs as follows:
 - The line must be strung tightly between 34 and 39 inches above the roof
 - The line’s tensile strength must be greater than 500 pounds.
 - The line must be flagged with high visibility flagging at six foot intervals.
 - The vertical supports must be substantial and not tipped easily and must be able to resist a force of 16 pounds.
 - The line must not be closer than six feet to the edge at any point for roofers.
 - A second line must be installed at least 15 feet back from the edge of the roof for all trades other than roofers.

Note: If a guardrail system has not been installed to provide protection during roofing operations, a two-line warning system must be installed. When work is needed between the warning line and the edge of the roof, a 100 percent fall protection plan is required at all times.

- 3) Guardrails
- 4) Personal fall arrest systems
- 5) Warning line that indicates a controlled access zone, with 100 percent fall protection plan when outside the warning line(s)

Safety Monitoring Systems in lieu of fall protection systems are not to be used at any time on Beeler Construction projects. If it is deemed that conventional fall

 <p>Partnerships Built on Trust</p>	11. Fall Protection	Page 21
SAFETY & HEALTH MANUAL	Revision Date: 12/23/2022	Updated:

protection measures cannot be used, the use of a safety monitor must be approved by the company's management.

 SAFETY & HEALTH MANUAL	Partnerships Built on Trust	11. Fall Protection	Page 22
		Revision Date: 12/23/2022	Updated:

On steep roofs (where pitch is greater than 4 to 12) employees must be protected by the following methods:

- elimination of the fall hazard
- guardrails
- personal fall arrest systems

Roof areas with pre-existing perimeter walls or parapets meeting the guardrail requirements in the Guardrail section do not require additional safeguarding, although special conditions may make these measures desirable.

Access to all roofs should be guarded against any fall hazard.

All materials and equipment must be stored a minimum of six feet away from the roof edge. Stacked materials must be self-supporting. Measures must be taken to eliminate public exposures from flying materials. Weigh down materials when not being immediately used.

Safety Procedures for Steep Pitched Roofs

Provisions must be made in the fall protection plan when working on steep pitched roofs. One of the following methods must be used:

- Scaffolds or platforms with guardrails can be erected tightly against the wall and with the edge of flat or pitched roofs.
- Safety nets can be suspended or hung to fill exposure areas where guardrails, cables, or other methods are not practical.
- Full body harness with lanyards can be utilized as fall restraint, so the employee can move to the roof's edge, but not beyond it.
- An engineered cable guardrail system may be used for tying off, only if designed to handle any expected forces imposed.
- An anchor point can be installed on the roof for tie-off with the appropriate lanyard as part of the fall arrest system.
- Motorized buggies, carts, etc. may only be used and stored in areas where employees are protected by either a warning line or guardrail system.
- Access areas where material is hoisted or raised on a conveyor or crane must be guarded. Guardrails must extend at least four feet horizontally on each side of the access point to protect those transferring the materials onto the roof.
- Materials may not be stored near roof edges and must be secured or weighted down at all times.

 Partnerships Built on Trust	11. Fall Protection	Page 23
	SAFETY & HEALTH MANUAL	Revision Date: 12/23/2022

Standards, Instructions, and Examples

Following are illustrations of the use of fall protection for roofing work.



Guarded access point to a roof – fully guarded



**Warning line 15 feet minimum from edge.
Note: Beeler Construction does not allow the Monitor system.
100% fall protection required when outside of the warning line.**

 SAFETY & HEALTH MANUAL	Partnerships Built on Trust	11. Fall Protection	Page 24
		Revision Date: 12/23/2022	Updated:

Working at Heights

Elevator/Mechanical, Electrical, and Plumbing (MEP) Shafts

Purpose

The purpose of this section is to establish requirements to protect and safeguard the public and employees, as well as to prevent damage to property, resulting from work around elevator and MEP shafts.

Scope

This section contains general requirements for all Electrical work involving working at heights around elevator/MEP shafts. These requirements apply to all managers, workers, and others who work on Beeler Construction projects. Everyone entering a Beeler Construction project, including all Beeler Construction employees, subcontractor employees, visitors, and owners shall comply with the requirements of this section.

Policies

When an elevator or MEP shaft in the building is under construction the shaft way takes shape as aligned openings in the floors. Working safely around these openings requires the use of a variety of safety measures. Beeler and its subcontractors may be working in/around shafts along with other contractors who may remove the guardrails, covers and create hazards. The section while help protect Beeler's workers and subcontractors from being exposed to hazards.

Elevator Doorways

When concrete wall forms are removed, ensure guards are at the elevator entrance until the permanent elevator doors are installed and secured in a closed setting. Do not work in or near the elevator doors if the guardrails have been removed.

Material Stored Near Shafts

To safely protect workers, all guardrail systems for shaft openings shall be protected by a net or screen from the toe board to the top rail to prevent materials from falling into the shaft opening.

Work Over Shaft Ways

Fall protection must be used even if the shaft ways are completely decked over. This includes work such as installing or dismantling protective wood decks over shafts and setting plumb wires for elevator rails.

Shaft Covers

Employees working inside shafts must be protected from falling materials by decking over the work area, covering the door openings, or installing debris netting. The cover should be installed before work inside the shaft begins. Decks inside the shaft (if any) must be securely anchored. Gravity decks are not allowed.

 SAFETY & HEALTH MANUAL	Partnerships Built on Trust	11. Fall Protection	Page 25
		Revision Date: 12/23/2022	Updated:

Floor and Wall Openings

Purpose

Openings in floors and walls are hazards on all project sites during construction. The following definitions and procedures outline standards on Beeler Construction projects for eliminating hazards related to openings in floors and walls and instructions for working safely near such hazards. Even though it may not be Beeler responsibility to install guardrails or floor cover, Beeler employees shall be aware of their work area and make sure you are not exposed to hazards. If a hazard is found, Beeler employees shall stop work until the hazard is fixed.

Scope

This section applies to all Beeler Construction projects and must be followed by all subcontractors and vendors at the project.

Floor Openings

A floor opening is a gap or void 2 inches (5.1 cm) or more in its least dimension in a floor, roof, or other walking/working surface. Examples include mechanical sleeves or chases.

Floor openings must be covered with plywood or materials of similar strength and be strong enough to withstand twice the maximum load expected.

The cover must be secured so that materials cannot fall through the opening to working areas below and so that it cannot be removed accidentally. As an alternative, install guardrails and toe boards at every permanent or temporary floor opening.

If using a standard guardrail system, it must:

- have a top rail, mid rail, and toe board
- protect all sides of the opening and
- use covers that are strong enough to support twice the anticipated loads

Hatchways and chutes must be guarded by a hinged cover with guardrails mounted so that only one side remains exposed for entry and exit.

Wall Openings

A wall opening is a gap or void 30 inches (76 cm) or higher and 18 inches (48 cm) or wider in a wall or partition through which employees can fall to a lower level. Examples include duct work openings, windows, louvers and exterior studs.

 SAFETY & HEALTH MANUAL	Partnerships Built on Trust	11. Fall Protection	Page 26
		Revision Date: 12/23/2022	Updated:

When the bottom edge of a wall opening is less than 39 inches above the walking surface it must be protected with a fall protection system (for example, a guard-rail system). A toe board must also be used when the bottom edge of the opening is less than 3 1/2 inches above the walking surface.

The opening may be completely covered instead of using a guardrail. If a cover is used, the covering material must be able to withstand a force of at least 200 pounds.

If the wall opening is to be used as a landing area, there must be:

- a clear area around the landing area at all times
- a removable guardrail that is only removed when materials are to be landed
- a personnel fall protection system for all personnel within the landing area when the guardrail is removed
- a second guardrail installed to enclose the landing area so that no other workers will be exposed to a potential fall or allowed in the landing area while loads are being received

The landing area shall not be used for storage. If the landing area is an outrigger platform, it must be designed by an engineer.

Signs and Labeling

Where covers are used, they must be labeled with a warning similar to the following: “Hole Opening – Do Not Remove”, “Cover – Do Not Remove”, or “Floor Opening-Do Not Remove”. When small hole covers are used, they shall be painted with highly visible orange or red paint.

Standards, Instructions, and Examples

Following are photographs illustrating safety measures for working near floor and wall openings:

Clearly Labeled Floor cover



Hole covers shall be secured from movement

 SAFETY & HEALTH MANUAL	Partnerships Built on Trust	12. Excavation Safety Procedures	Page 1
		Revision Date: 1/8/2024	Updated

Excavation Safety Procedures

PURPOSE: To provide a safe and healthful workplace for all Beeler Construction employees and employees of subcontractors and to ensure that the hazards of cave-ins are properly evaluated and protected during trenching and excavating operations where employees must enter the area of the trench or excavation.

POLICY: Beeler Construction provides a safe and healthful workplace for all employees and subcontractors and will ensure that the hazards of trenching and excavating operations are protected through proper evaluation and protection as required in OSHA's Excavation Standard 29 CFR Subpart P. The requirements below must be followed by all Beeler Construction employees and subcontractors.

TRAINING: All Beeler Construction employees shall receive initial excavation safety training and periodic training thereafter. All training is to be provided by a qualified person that is competent in excavation safety. Training is to be documented, employee name, date of training and trainer will be recorded.

PROCEDURES:

▼ Trench/Excavation Safety Evaluation:

All excavations **MUST** be inspected on a daily basis. Inspections are to be performed by a designated Competent Person before workers are allowed in the trenching area. Further inspections are performed periodically during work activities. Beeler Construction's site foreman/superintendent will be designated as the Competent Person. Beeler Construction requires that the equipment operator also be trained and designated as the Competent Person. The Competent Person is trained to identify existing and predictable hazards, if work conditions are deemed hazardous, work is to immediately stop and the excavation area is to be evacuated, workers will not be allowed to re-enter the trench area until conditions are corrected.

- 1) Before any employee may enter a trench or excavated area of the earth, the safety of that trench and need for protective sloping or shoring, must first be evaluated by the designated Competent Person at the jobsite.
- 2) Before any worker may enter a trench that may contain hazardous atmospheres, such as trenching in or near a landfill or trenching where hazardous substances may be stored nearby, atmospheric testing **MUST** be performed prior to entry. Atmospheric testing must also be performed periodically during work activities within such trenching. All atmospheric test results are to be recorded and all records are to be maintained by Beeler Construction's site foreman/superintendent.

 Partnerships Built on Trust SAFETY & HEALTH MANUAL	12. Excavation Safety Procedures	Page 2
	Revision Date: 1/8/2024	Updated

- 3) Before any worker may enter a trench or excavated area, the Competent Person must inspect the area for water accumulation. Employees shall not work in excavations in which there is accumulated water, or in excavations in which water is accumulating, unless adequate precautions have been taken to protect employees against the hazards posed by water contamination. The precautions necessary to protect employees adequately vary with each situation, but could include special support of shield systems to protect from cave-ins, water removal to control the level of accumulating water, or use of a safety harness and lifeline.
If water is controlled or prevented from accumulating by the use of water removal equipment, the water removal equipment and operations shall be monitored by a Competent Person to ensure proper operation. If excavation work interrupts the natural drainage of surface water (such as streams), diversion ditches, dikes or other suitable means shall be used to prevent surface water from entering the excavation and to provide adequate drainage of the area adjacent to the excavation. Excavations subject to runoff from heavy rains will require an inspection by a competent person and compliance with paragraphs (h) (1) and (h) (2) of this section.
- 4) The Competent Person has final authority for determining the safety of a trench or excavation and has the authority to order all Beeler Construction employees or employees of subcontractors from the trench or excavation until conditions allow safe re-entry, or additional sloping or shoring ensures the safe re-entry of personnel.
- 5) The Competent Person is responsible for performing the following tasks during any excavation or trenching operation:
 - ✓ Classifying soil conditions in the excavation or trench based on visual and manual tests that follow.
 - ✓ Conducting and documenting daily inspections of all open excavations and trenches using the inspection form in this procedure.
 - ✓ Determining whether trenched excavations less than five feet in depth are safe and do not require sloping or shoring.
 - ✓ Conducting and documenting inspections of all open excavation and trenches after an occurrence of rain or other condition that could affect the safety of open trenches and excavations.

▼ **Soil Conditions & Types:**

The Competent Person shall classify soil conditions according to the following descriptions:

Type A

Type A soil means cohesive or cemented soils with an unconfined compressive strength of 1.5 tons per square foot or greater. Typical type A soils include clays, caliche and hardpan. Soils that have been previously disturbed are subject to vibration, are submerged in water or are fissured may not be classified as Type A.

 <p>Partnerships Built on Trust</p> <p>SAFETY & HEALTH MANUAL</p>	<p>12. Excavation Safety Procedures</p>	<p>Page 3</p>
	<p>Revision Date: 1/8/2024</p>	<p>Updated</p>

Type B

Type B soil means cohesive soil with an unconfined compressive strength greater than .5 tons per square foot but less than 1.5 tons per square foot. Type B soil also means granular cohesionless soils. Granular soil means gravel, sand or silt (coarse grained soil) with little or no clay content. Granular soil has no cohesive strength. Granular soil cannot be molded when moist and crumbles easily when dry. Soils that have been previously disturbed are subject to vibration, are submerged in water or are fissured may not be classified as Type B.

Type C

Type C soil means cohesive soil with an unconfined compressive strength of .5 tons per square foot or less. Type C soils also include granular soils such as gravel, sand, loam, submerged soils or soils which moisture is flowing freely from, or submerged rock that is not stable.

Stable Rock

Stable rock means natural solid mineral matter that can be excavated with vertical sides and remain intact while exposed.

Soil Properties

- a) Cohesive Soil: Cohesive soil means clay (fine grained soil) or soil with high clay content, which has cohesive strength. Cohesive soil does not crumble, can be molded or formed without cracking when moist, is hard to break up when dry.
- b) Cemented Soil: Cemented soil means a soil in which the particles are held together by a chemical agent, such as calcium carbonate, such that a hand-size sample cannot be crushed into powder or individual soil particles by finger pressure.

▼ Visual & Manual Testing:

The Competent Person shall classify soil conditions according to one of the types described above based on at least one visual and one manual test described below.

Visual Tests:

- a) Visual tests are conducted by the Competent Person to determine the type of soil based on the soil's appearance, conditions and particle size.
- b) Samples of soil that has been excavated and samples of soil taken from the sides of the excavation should be examined:
 - ✓ Soil that is primarily composed of fine-grained material is **cohesive soil**.
 - ✓ Soil composed primarily of coarse-grained sand or gravel is **granular soil**.
 - ✓ Soil should be examined as it is excavated. Soil that remains in clumps when excavated is **cohesive soil**.
 - ✓ Soil that breaks up easily and does not stay in clumps is **granular soil**.
 - ✓ The sides of the opened excavation should be observed. Crack-like openings such as tension cracks could indicate **fissured soil**.
 - ✓ Chunks of soil that spall off of a vertical side of an excavation could indicate **fissured soil**.

 Partnerships Built on Trust	12. Excavation Safety Procedures	Page 4
	Revision Date: 1/8/2024	Updated

SAFETY & HEALTH MANUAL

- ✓ Small spalls indicate the presence of moving around, vibrations or potentially hazardous situations that could result in cave-in.
- ✓ Areas adjacent to the excavation and the excavation itself should be observed for:
 - Evidence of existing utility and other underground structures.
 - Evidence of previously disturbed soil which could contribute to instability of excavation.
- ✓ The opened sides of the excavation should be observed for:
 - Layered soil systems that slope toward the excavation that could contribute to instability.

Manual Tests:

The Competent Person shall conduct manual tests in order to make a quantifiable determination of soil conditions present in the excavation or trench. The following manual tests shall be conducted and documented to determine soil types present in the excavation:

- a) Plasticity Test: Mold a moist or wet sample of soil into a ball and attempt to roll it into threads as thin as 1/8 inch in diameter. If the material can successfully be rolled into threads without crumbling, the soil is **cohesive**.
- b) Dry Strength Test: If the soil is dry and crumbles on its own or with moderate pressure into individual grains or fine powder, the soil is **granular**. If the soil is dry and falls into clumps that break up into smaller clumps, but the smaller clumps can be broken up with difficulty, the soil may be **clay in combination with gravel, sand or silt**. If the dry soil breaks into clumps which do not break up into small clumps and which can only be broken with difficulty and there is no visual indication the soil is fissured, the soil may be **unfissured**.
- c) Thumb Penetration Test: If the soil can readily be indented by the thumb but can only be penetrated by the thumb with very great effort, the soil type may be **Type A**. If the soil can easily be penetrated several inches by the thumb and can be easily molded with light finger pressure, the soil type may be **Type B**. *Thumb Penetration Tests should be conducted on an undisturbed soil sample, such as a large clump of soil, as soon as practicable after excavation to reduce the effects of drying on the sample.*

▼ General Safety Requirements for all Trenches/Excavations:

- 1) A ladder or ramp shall be provided for all trench excavations that are greater than 4 feet in depth. An adequate number of ladders shall be provided so that no more than 25 feet of travel is required to locate a ladder or ramp.
- 2) No employee shall be permitted to stand or work underneath loads handled by lifting or digging equipment. Employees shall be required to stand away from any vehicle being loaded or unloaded to avoid being struck by any spillage or falling materials.
- 3) A warning system such as barricades, hand signals or stop logs shall be used when equipment is operating near an excavation and the operator does not have a clear and direct view of the edge of the excavation.
- 4) Employees in an excavation shall be protected from falling material by placing excavated material at least 2 feet from the edge of all excavations and trenches. Materials and equipment shall also be placed at least 2 feet from the edge.

 Partnerships Built on Trust	12. Excavation Safety Procedures	Page 5
	SAFETY & HEALTH MANUAL	Revision Date: 1/8/2024

- 5) Employees in an excavation of any depth shall be protected from potential loose rock or soil by scaling the vertical walls of an excavation to remove any loose material. Protective barricades may also be installed to protect against loose or falling material.
- 6) Utility locates must be performed prior to the start of any digging activity. Operators must use caution when digging in the event utilities have shallow burial depth.
- 7) Employees must not work in excavations in which water has accumulated or excavations in which water is accumulating until the water has been first removed. All pumps must be monitored by a Competent Person.
- 8) The Competent Person must ensure that excavations do not undermine or endanger adjacent structures, including poles, light standards, signs, buildings and foundations. An engineer should be consulted if the excavation may affect the structural integrity of a nearby building or structure.
- 9) Excavations greater than 4 feet in depth where the presence of a hazardous atmosphere is expected must be handled as a confined space. Consult the confined space entry procedure in this safety manual.
- 10) Whenever a trench or excavation results in a fall situation risk, employees must be protected by the use of Fall Protection. Type and methods of protection will be determined by the condition, excavation areas may require barricades around the perimeter of the dig. If crosswalks are introduced, they must include an approved guard rail system.

▼ **Trenches/Excavations Less than 5 Feet in Depth:**

- 1) The general safety precautions above must be followed for all excavations 5 feet in depth or less.
- 2) Before any employee enters an excavation of 5 feet in depth or less, an examination by a Competent Person must first determine that potential hazard from cave-in does not exist.
- 3) If an examination by a Competent Person determines that a cave-in hazard does not exist, employees may safely enter a non-sloped, non-shored excavation.
- 4) If conditions change and create the potential for cave-in in a non-sloped or non-shored excavation, the Competent Person should require employees to exit the area of the excavation or trench and properly slope or shore the excavation according to tests and soil conditions described above.

▼ **Trenches/Excavations 5 Feet or More in Depth:**

- 1) The general safety precautions above must be followed for all excavations 5 feet in depth or greater.
- 2) All excavations 5 feet in depth or greater must be evaluated by a Competent Person before any employee or subcontractor enters the excavation or trench.
- 3) The Competent Person shall determine the classification of soil (Stable Rock, Type A, Type B, Type C) using the visual and manual test methods described earlier in this procedure.

 Partnerships Built on Trust	12. Excavation Safety Procedures	Page 6
	SAFETY & HEALTH MANUAL	Revision Date: 1/8/2024

- 4) Based on the classification of soil made by the Competent Person, the excavation shall either be sloped according to the diagrams contained in the appendix to this procedure, shored according to the tables provided in the appendix or protected by trench shields according to the tables in the appendix of this procedure.
- 5) The Competent Person may elect to consider all soils as Type C and protect accordingly without having to do a soils analysis.

▼ **Working Near Underground Utilities:**

No trenching or excavating work shall begin without a current underground locate. The person/company operating the trenching/excavating equipment must be the one to call for the locate. Another company such as Beeler Construction, shall not call for a locate in place of the equipment operator.

Hand digging is required when trenching or excavating within 18 inches of either side of an underground locate marking. Never make any assumptions regarding the depth of the underground utility. Always proceed as if the utility is located just beneath the ground surface.

When poor soil situations exist thereby making hand digging difficult or ineffective, hydro-excavating is a safe and effective alternative to hand digging. Contact the project manager and safety director for assistance with evaluating hydro-excavating needs **Summary of Trenching/Excavation Procedures.**

- 1) The general safety precautions for trenches and excavations shall be followed for all trenches and excavations of any depth.
- 2) The designated Competent Person must evaluate ALL trenches and excavations to determine the classification of soil conditions and hazards that may be present. Soil analysis need not be performed if ALL soils are considered to be Type C and protected accordingly.
- 3) Employees may work in non-sloped, non-shored trenches or excavations less than 5 feet in depth after evaluation by the Competent Person determines that potential for cave-in does not exist.
- 4) Trenches or excavations 5 feet or greater in depth MUST be sloped, shored or protected by trench shields. Other engineered systems such as sheet piling or piers and soldier beams may be used. The slope of the trench or excavation or shoring or trench shields used will be based on the classification of soil determined by the designated Competent Person.
- 5) The designated Competent Person must have the final authority for determining the safety and conditions of all trenches and excavations.

The following are the OSHA general guidelines for maximum allowable slopes and slope configurations per soil types.

**TABLE B-1
MAXIMUM ALLOWABLE SLOPES**

SOIL OR ROCK TYPE	MAXIMUM ALLOWABLE SLOPES (H:V)(1) FOR EXCAVATIONS LESS THAN 20 FEET DEEP(3)
STABLE ROCK	VERTICAL (90°)
TYPE A (2)	3/4:1 (53°)
TYPE B	1:1 (45°)
TYPE C	1 ½:1 (34°)

Footnote (1) Numbers shown in parentheses next to maximum allowable slopes are angles expressed in degrees from the horizontal. Angles have been rounded off.

Footnote(2) A short-term maximum allowable slope of 1/2H:1V (63°) is allowed in excavations in Type A soil that are 12 feet (3.67 m) or less in depth. Short-term maximum allowable slopes for excavations greater than 12 feet (3.67 m) in depth shall be 3/4H:1V (53°).

Footnote (3) Sloping or benching for excavations greater than 20 feet deep shall be designed by a registered professional engineer.

 Partnerships Built on Trust SAFETY & HEALTH MANUAL	12. Excavation Safety Procedures	Page 8
	Revision Date: 1/8/2024	Updated

Figure B-1

Slope Configurations

(All slopes stated below are in the horizontal to vertical ratio)

B-1.1 Excavations made in Type A soil.

1. All simple slope excavation 20 feet or less in depth shall have a maximum allowable slope of $\frac{3}{4}$:1.

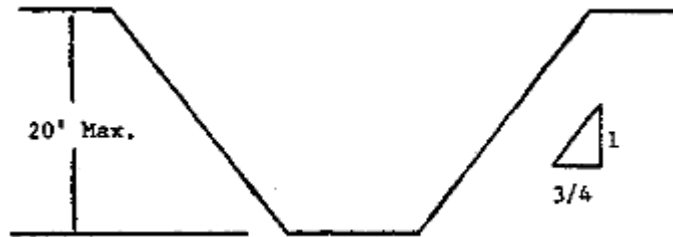

SIMPLE SLOPE -- GENERAL

Exception: Simple slope excavations which are open 24 hours or less (short term) and which are 12 feet or less in depth shall have a maximum allowable slope of $\frac{1}{2}$:1.

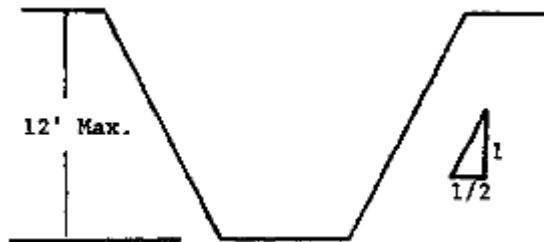

SIMPLE SLOPE -- SHORT TERM



Partnerships
Built on Trust

SAFETY & HEALTH MANUAL

12. Excavation Safety Procedures

Page
9

Revision Date: 1/8/2024

Updated

2. All benched excavations 20 feet or less in depth shall have a maximum allowable slope of 3/4 to 1 and maximum bench dimensions as follows:

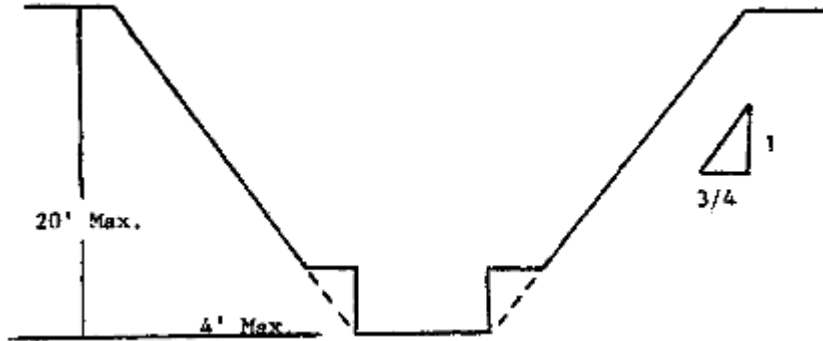

SIMPLE BENCH

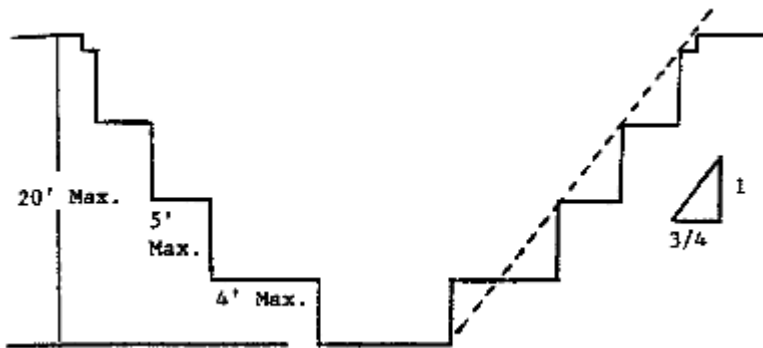

MULTIPLE BENCH

3. All excavations 8 feet or less in depth which have unsupported vertically sided lower portions shall have a maximum vertical side of 3 1/2 feet.

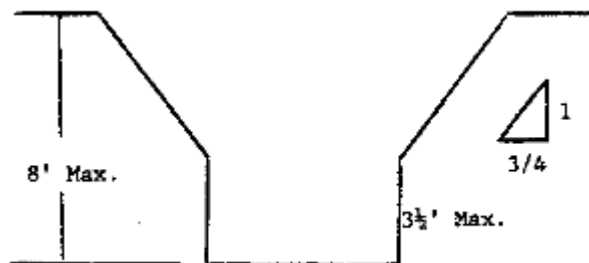

UNSUPPORTED VERTICALLY SIDED LOWER PORTION – (MAXIMUM 8 FEET IN DEPTH)

 Partnerships Built on Trust SAFETY & HEALTH MANUAL	12. Excavation Safety Procedures	Page 10
	Revision Date: 1/8/2024	Updated

All excavations more than 8 feet but not more than 12 feet in depth with unsupported vertically sided lower portions shall have a maximum allowable slope of 1:1 and a maximum vertical side of 3½ ft.

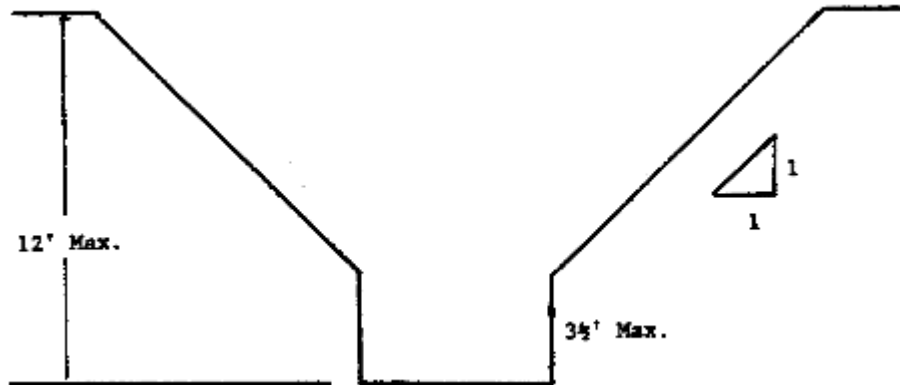

UNSUPPORTED VERTICALLY SIDED LOWER PORTION -- MAXIMUM 12 FEET IN DEPTH)



Partnerships
Built on Trust

SAFETY & HEALTH MANUAL

12. Excavation Safety Procedures

Page
11

Revision Date: 1/8/2024

Updated

All excavations 20 feet or less in depth which have vertically sided lower portions that are supported or shielded shall have a maximum allowable slope of $\frac{3}{4}$:1. The support or shield system must extend at least 18 inches above the top of the vertical side.

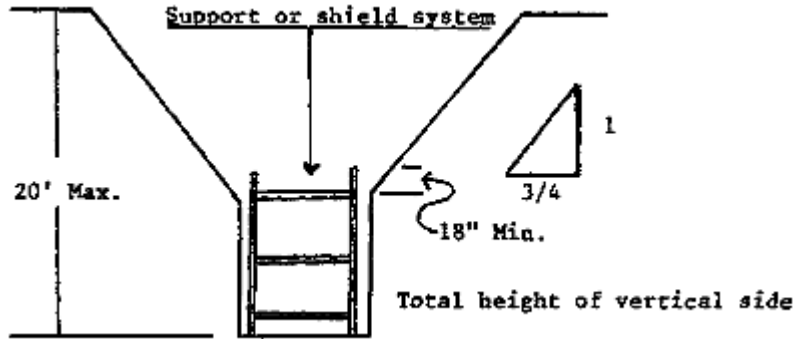

SUPPORTED OR SHIELDED VERTICALLY SIDED LOWER PORTION

4. All other simple slope, compound slope, and vertically sided lower portion excavations shall be in accordance with the other options permitted under § 1926.652(b).

B-1.2 Excavations Made in Type B Soil

1. All simple slope excavations 20 feet or less in depth shall have a maximum allowable slope of 1:1.

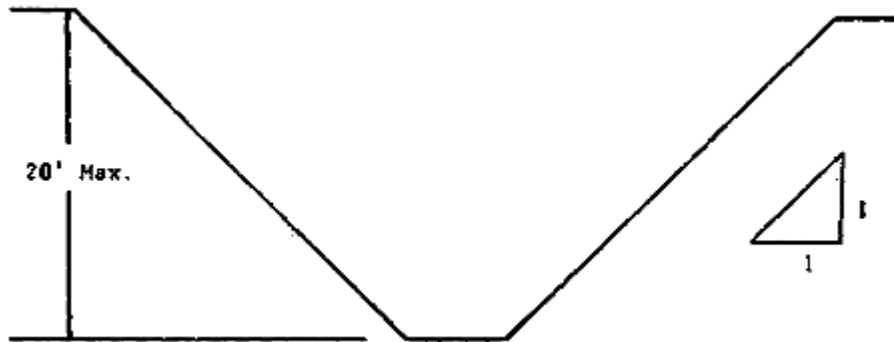

SIMPLE SLOPE



Partnerships
Built on Trust

SAFETY & HEALTH MANUAL

12. Excavation Safety Procedures

Page
12

Revision Date: 1/8/2024

Updated

2. All benched excavations 20 feet or less in depth shall have a maximum allowable slope of 1:1 and maximum bench dimensions as follows:

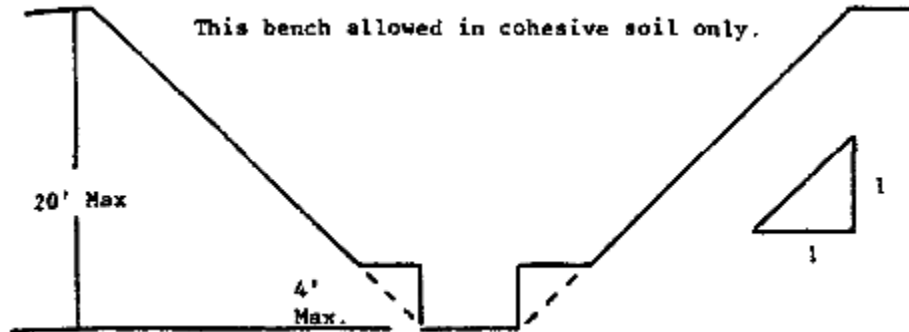

SINGLE BENCH

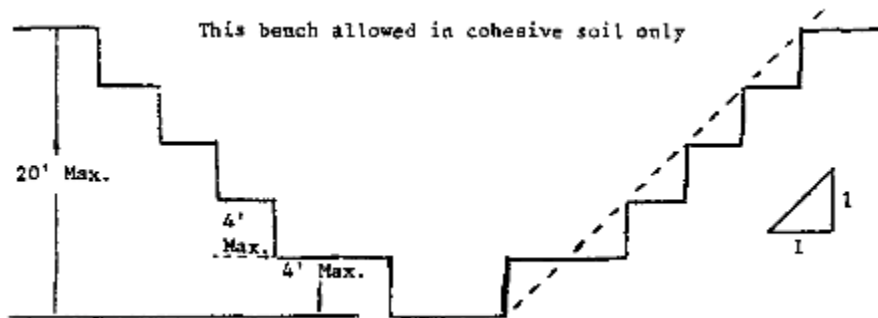

MULTIPLE BENCH

3. All excavations 20 feet or less in depth which have vertically sided lower portions shall be shielded or supported to a height at least 18 inches above the top of the vertical side. All such excavations shall have a maximum allowable slope of 1:1.

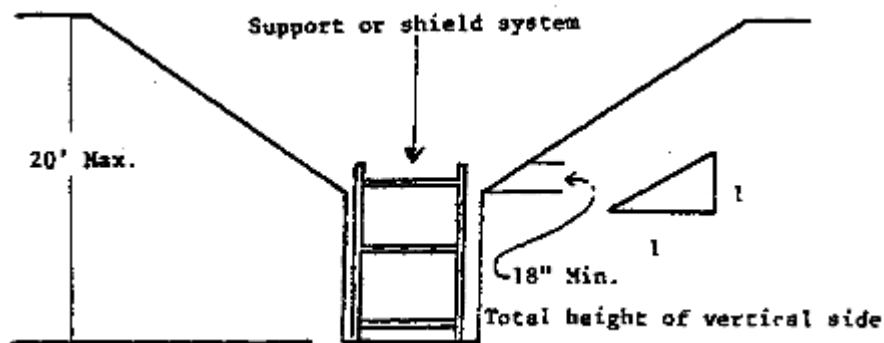

VERTICALLY SIDED LOWER PORTION

4. All other sloped excavations shall be in accordance with the other options permitted in § 1926.652(b).



Partnerships
Built on Trust

SAFETY & HEALTH MANUAL

12. Excavation Safety Procedures

Page
13

Revision Date: 1/8/2024

Updated

B-1.3 Excavations Made in Type C Soil

1. All simple slope excavations 20 feet or less in depth shall have a maximum allowable slope of 1½:1.

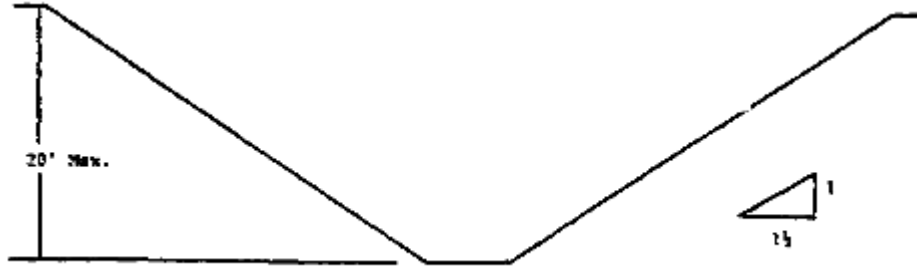

SIMPLE SLOPE

2. All excavations 20 feet or less in depth which have vertically sided lower portions shall be shielded or supported to a height at least 18 inches above the top of the vertical side. All such excavations shall have a maximum allowable slope of 1½:1.

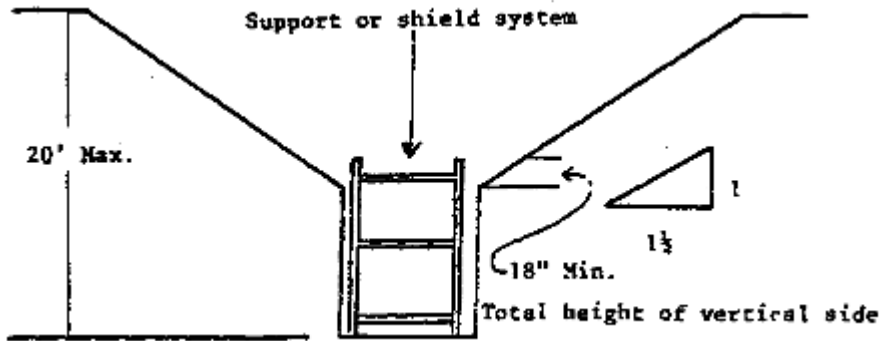

VERTICAL SIDED LOWER PORTION

3. All other sloped excavations shall be in accordance with the other options permitted in § 1926.652(b).



Partnerships
Built on Trust

SAFETY & HEALTH MANUAL

**12. Excavation Safety
Procedures**

**Page
14**

Revision Date: 1/8/2024

Updated

B-1.4 Excavations Made in Layered Soils

1. All excavations 20 feet or less in depth made in layered soils shall have a maximum allowable slope for each layer as set forth below.

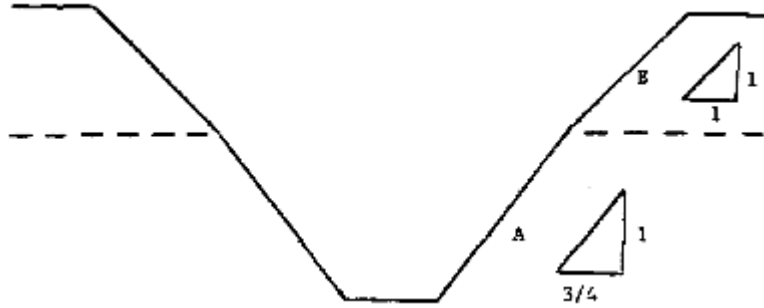

B OVER A

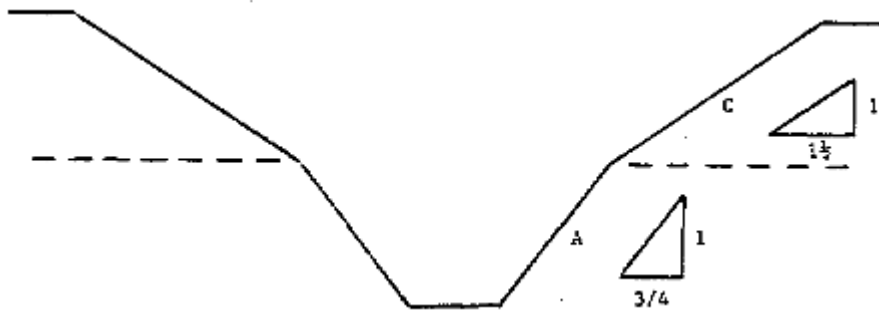

C OVER A

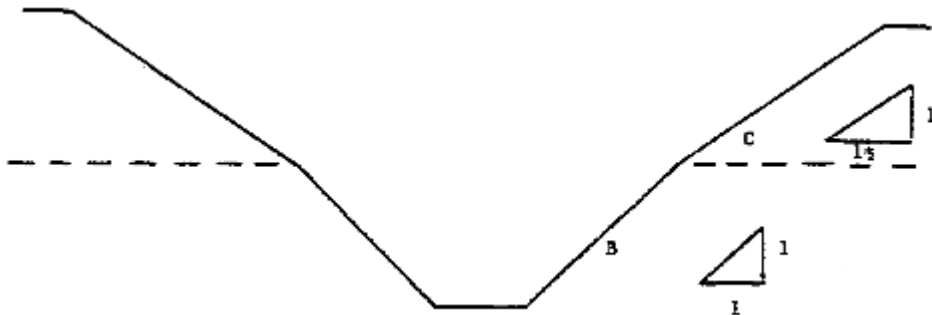

C OVER B

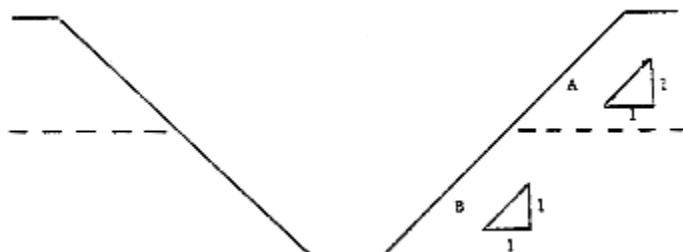

A OVER B



Partnerships
Built on Trust

SAFETY & HEALTH MANUAL

**12. Excavation Safety
Procedures**

**Page
15**

Revision Date: 1/8/2024

Updated

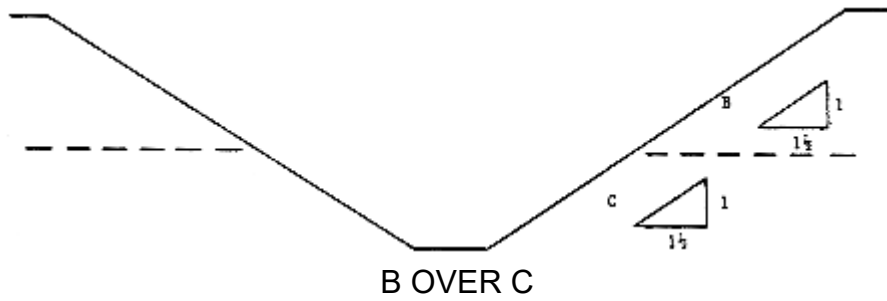
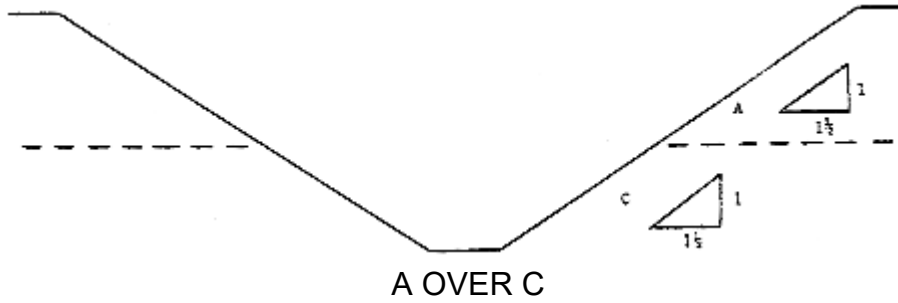



Partnerships
Built on Trust

SAFETY & HEALTH MANUAL

12. Excavation Safety Procedures

**Page
16**

Revision Date: 1/8/2024

Updated

Trenching and Excavation Safety Checklist

The following checklist is to be used for all excavation and trenching projects.

Project:		Location:		
Assigned Competent Person (CP):		Phone #		
Excavation review completed by:		Phone #		
Department:				
Excavation and Protective Systems		Yes	No	N/A
Is the site cleared for utilities and other underground obstructions?				
Are the utilities marked-out?				
Do underground installations need to be protected, supported or removed? How will this be done?				
Have surface encumbrances been removed or supported? If so, please name/explain.				
Is excavated material placed 2 feet or more from the edge?				
Has equipment been checked by the operator?				
Is anticipated depth 5 feet or greater? Has it been reviewed by the CP?				
Have provisions been made for shielding, shoring, sloping or benching? Please describe or state type of protective system.				
Has the equipment been inspected?				
Are support systems provided to stabilize adjacent structures, buildings, roadways, sidewalks, etc.?				
Have the support systems been installed without exposing employees to cave-ins, collapses or "struck-bys?"				
Are the sides of the support system no more than 1 foot below the level of the ground?				
Is the bottom of the excavation no more than 2 feet below the level of the support system?				
Will the removal of the support systems progress from the bottom and progress slowly?				
Will backfilling begin immediately upon removal of support systems?				
Are the protective system's materials and equipment in good condition?				
Have the protective systems been inspected? If so, please write name.				
Have any inspected materials or equipment been removed from service? If so, which?				
Are undermined structures adequately supported for anticipated loads and are workers protected?				
Is the excavation well marked and barricaded to prevent personnel or vehicles from falling in?				

 Partnerships Built on Trust SAFETY & HEALTH MANUAL	13. Ladders and Stairs	Page 1
	Revision Date: 1/8/2024	Updated

Ladders & Stairs

PURPOSE: The purpose of this procedure is to provide requirements for the safe use, erection and dismantlement of scaffolding and ladders used by Beeler Construction employees and employees of subcontractors. This document is a summary of OSHA’s comprehensive requirements contained in 29 CFR 1926, Subpart X concerning the use of ladders and stairways.

POLICY: Beeler Construction provides a safe and healthful workplace for all of its employees. This procedure summarizes the main requirements of OSHA’s comprehensive ladder and stairway requirements. This procedure applies to all jobsites, activities and situations where Beeler Construction employees and subcontractor employees erect and use ladders and permanent or temporary stairways.

PROCEDURES:

▼ Ladders:

General Requirements & Safe Work Practices:

- 1) All ladders used on Beeler Construction jobsites MUST be in compliance with OSHA Standard 29 CFR 1926.1053 “Ladders” and must also meet the requirements set forth by ANSI ASC A14.3.
- 2) Ladders may only be used for the purpose they were designed, never place ladders on top of boxes, barrels, crates, etc., never use a ladder in horizontal position or as scaffolding.
- 3) Ladders shall be used at an angle such that the horizontal distance from the top support to the foot of the ladder is approximately one-quarter the working length of the ladder.
- 4) A ladder or stairway shall be provided at all personnel points of access where there is a break in elevation of 19 inches or more.
- 5) Ladders must be inspected prior to each use for chips, cracks and other defects.
- 6) If inspection reveals a defect, it must be removed from service until repaired.
- 7) Rungs must be kept clean and free of mud, grease or oil to prevent slips and falls.
- 8) Where possible, ladders must always be secured or lashed at the top of the ladder to prevent their tipping.
- 9) When portable ladders are used to access upper landings/levels, the ladder side rails must extend at least 36 inches above the landing or roof surface. Fixed ladder side rails must extend 42” above the landings or roof surfaces.
- 10) Cross bracing on the rear section of step ladders must not be used for climbing unless it is designed and provided with steps for climbing on both sections.

 Partnerships Built on Trust SAFETY & HEALTH MANUAL	13. Ladders and Stairs	Page 2
	Revision Date: 1/8/2024	Updated

- 11) Employees must always face the ladder when climbing.
- 12) The base of extension ladders must be placed no closer to the structure than one fourth of the extended length of the ladder.
- 13) The areas at the top and bottom of each ladder must be kept clear of rubbish, debris and equipment.
- 14) Step ladders must NEVER be “walked” across the floor. Employee must move and properly set the ladder in place.
- 15) Self-supporting ladders and portable ladders must be capable of supporting at least 4 times the maximum intended load with the exception of type 1A metal or plastic ladders which must be capable of supporting 3.3 times the maximum intended load.
- 16) Fixed ladders must be capable of supporting two loads of 250 lbs. concentrated between any two consecutive attachments, including any anticipated loads from ice build-up, wind, rigging, impact loads from ladder safety devices, etc. Each step or rung must be capable of supporting 250 lbs. applied in the middle of the step or rung.
- 17) Step Ladders near guardrails shall be no closer than the ladders height away. (i.e. a 12-foot step ladder shall be 12 feet away).

Job Made Ladder Construction Requirements:

- 1) Single cleat ladders must not exceed 30 feet in length.
- 2) Double cleat ladders must not exceed 24 feet in length.
- 3) 2 inch x 4 inch lumber must be used for side rails of single cleat ladders up to 16 feet in length.
- 4) 2 inch x 6 inch lumber must be used for side rails of single cleat ladders from 16-30 feet in length.
- 5) 2 inch x 4 inch lumber must be used for side and middle rails of double cleat ladders up to 13 feet in length.
- 6) 2 inch x 6 inch lumber must be used for side and middle rails for double cleat ladders from 12-24 feet in length.
- 7) Cleats on single cleat ladders must be made from 1 inch x 4 inch (or greater) lumber.
- 8) The cleats cannot exceed 20 inches in length on single cleat ladders.
- 9) Cleats on double cleat ladders must be made from 2 inch x 4 inch lumber.
- 10) Cleats must be inset into the edges of the side rails or filler blocks must be used on the rails between the cleats.
- 11) Cleats must be uniformly spaced, 12 inches top-to-top.

▼ Stairways:

General Requirements:

- 1) A stairway or ladder shall be provided at all personnel points of access where there is a break in elevation of 19 inches or more.
- 2) Landing areas at the top and bottom of all jobsite stairways must be kept clear of construction materials and debris.

 Partnerships Built on Trust	13. Ladders and Stairs	Page 3
	Revision Date: 1/8/2024	Updated
SAFETY & HEALTH MANUAL		

- 3) Stairs not permanent to the structure which construction work is being performed shall have landings not less than 30" in the direction of travel and extend 22" in width at every 12' or less of vertical rise.
- 4) Stairs shall be installed between 30 degrees and 50 degrees from horizontal.
- 5) Stair tread surfaces must be kept clear of tools, materials and debris to prevent persons from tripping when climbing the stairs.
- 6) Care must be taken when using electrical cords from one level to another. Cords must not be placed across stair treads creating a tripping hazard. Cords should be secured to stair rail systems or balusters when they are placed in stairways.
- 7) The riser height and tread depth must be kept uniform on each flight of stairs. Variations in riser height or tread depth must be less than ¼ inch.
- 8) Where doors open directly onto a stairway landing or platform, the landing or platform must allow at least 20 inches of clearance between the width of the door when open and the edge of the platform.
- 9) All parts of a stairway must be free of protrusions such as nails, ends of wire rope, etc.
- 10) Care must be taken to remove water, oil, snow, ice, etc. from stairs prior to use by workers to prevent slips and falls.
- 11) Metal pan stair treads must be filled in with wood or solid material up to the top edge of each pan. This includes pan stairs that are awaiting installation of tile over concrete where plywood can be used to fill to the top of the pan edge.

Stair Rail & Handrail Requirements:

- 1) Stairs that have either more than 4 risers or that rise more than 30 inches from one level to another must be provided with at least one handrail and a stair rail system installed along all unprotected sides of the stairs.
- 2) Handrails and stair rail systems can be combined or they may be installed opposite of each other separately.
- 3) Handrails must be installed so that there is at least 3 inches of clearance between the wall and the inside surface of the handrail to allow the employees hand to slide when climbing.
- 4) Handrails and stair rail systems must be capable of withstanding at least 200 pounds of force applied in any downward or outward direction at any point along the top edge.
- 5) The height of a handrail that is separate from a guard rail system must be between 30 and 37 inches when measured from the top surface of the handrail to the top surface of the tread in line with the face of the riser.
- 6) If the top edge of a stair rail system serves as the handrail, the height of the handrail must be between 36 and 37 inches when measured from the top surface of the handrail to the top surface of the tread in line with the face of the riser.
- 7) Handrail and stair rail systems must be free of splinters, splits, cracks, etc. that can injure worker's hands when climbing.
- 8) The ends of handrails and stair rails must be installed so that they do not project into walkways and work areas.

 Partnerships Built on Trust SAFETY & HEALTH MANUAL	14. Lockout-Tagout Program	Page 1
	Revision Date: 1/8/2024	Updated

Lockout-Tagout Program

PURPOSE: To provide the requirements for the lockout or tagout of energy isolating devices whenever work is performed or servicing is done on building equipment, machinery and vehicles. The following procedures shall be used to ensure that machinery and equipment is stopped, isolated from all potentially hazardous energy sources and locked out before Beeler Construction employees or Beeler Construction subcontractors perform any servicing or maintenance where the unexpected energization, start-up of machinery or equipment or release of stored energy could cause injury.

POLICY: Beeler Construction provides a safe and healthful workplace for all employees and contractors through the establishment of rules, procedures and programs that are strictly enforced in all work areas and locations. This procedure covering the maintenance of energized machinery, equipment and vehicles shall be adhered to by all Beeler Construction employees and contractors during work on such equipment.

TRAINING: All Beeler Construction employees affected by this lockout/tagout procedure shall receive initial training and annual refresher training. The purpose of the training shall be to ensure that the knowledge and skills required for the safe application, usage and removal of energy controls are communicated to affected employees. The level of training for servicing employees must include the actual procedures necessary to safely deactivate lockout and repair affected facility and building equipment and machinery. All training must be documented and signed/certified by the trainer.

The content of the training program shall include the following:

- ✓ The recognition of applicable hazardous energy sources, the type and magnitude of the energy source available in the work area and the methods necessary for energy isolation and control.
- ✓ The application and use of this lockout/tagout procedure and machinery and equipment specific procedures.
- ✓ The penalties for violation of this procedure.

 Partnerships Built on Trust SAFETY & HEALTH MANUAL	14. Lockout-Tagout Program	Page 2
	Revision Date: 1/8/2024	Updated

PROCEDURES:

▼ Notification:

The Beeler Construction employee or outside contractor authorized and qualified to maintain or service affected equipment should notify the Beeler Construction superintendent or other contractor on site, that the affected equipment will be shut down and locked out to perform the planned work.

▼ Deactivation:

Any employee deactivating or turning off any machine or equipment must be authorized prior to doing so. This authorized employee must be familiar and have knowledge of the machine or equipment involved, they must also have knowledge of: the type and magnitude of the energy, the hazards of the energy to be controlled and the methods and means to control the energy.

The employee shall deactivate the machinery or equipment to be worked on by shutting it down using normal stopping or deactivating procedures. This may be accomplished by depressing a stop button, turning an on/off switch, closing a valve or turning off and removing keys from the vehicle or heavy equipment.

Final deactivation and isolation shall be accomplished by opening the service disconnect, switch or valve, and applying a locking device. Some equipment may be deactivated and isolated by removing a fuse, removal and securement of the electrical plug, or removal of vehicle keys.

Only properly trained personnel shall be allowed to deactivate equipment when there is exposure to energized electrical components such as fuses, capacitors, electrical leads on motors, etc. No other personnel will be allowed to isolate or deactivate equipment that exposes them to energized electrical components. Appropriate safety precautions shall be taken such as the use of eye and face protection when working around energized electrical components. Generally, electrical work that may expose employees to energized electrical components will be performed by qualified, contracted electricians.

▼ Isolation:

Electrical:

After the equipment has been deactivated using normal methods to shut it down, electrical power shall be isolated from the machinery or equipment by shutting off the source of electrical feed by opening (turning off) electrical service disconnects, shutting switches off at the motor control center, opening the appropriate circuit at the circuit breaker panel or simply by removing the electrical plug from the outlet.

 Partnerships Built on Trust SAFETY & HEALTH MANUAL	14. Lockout-Tagout Program	Page 3
	Revision Date: 1/8/2024	Updated

Most newer equipment is furnished with a lockable service disconnect. Some equipment is equipped with plug type connections; procedures are explained below. All service disconnect furnished equipment should be identified through a marking system that corresponds to identical markings on the service disconnect for that equipment.

Pneumatic & Hydraulic:

Equipment that operates with pneumatic energy must be isolated by disconnecting the source of air by closing valves to the equipment or by uncoupling or disconnecting air hoses or lines from the equipment to be serviced. Air lines that are not equipped with quick disconnect type connections must be removed with caution. Air pressure should first be bled from all non-quick disconnect type hose or air line connections to prevent injury to the employees disconnecting lines under pressure. Hydraulic systems should be isolated by shutting off power to pump systems and in some cases, removing stored pressure within hydraulic lines and cylinders.

▼ Lockout:

Once electrical power to the machinery or equipment has been isolated, a lock shall be placed through the switch, hasp or handle to prevent unauthorized activation of the machinery or equipment. If the equipment is plug connected, a device may be placed over the plug end and a lock placed on the device to prevent persons from plugging the machine or equipment into an outlet before servicing or maintenance has been completed, however the locking out of plug type connections is not required.

Subcontractors will be expected to furnish their own locks for work covered by this procedure. Specific requirements concerning contractors are covered later in this procedure. The employee performing maintenance shall be the only individual in possession of the key for their lockout lock. A multiple locking hasp must be used when more than one person is working on the machine or equipment, including outside contractors that may be working on equipment.

▼ Tagout:

If isolation of electrical power to machinery or equipment can only be accomplished through removal of an electrical power cord or removal of electrical leads or fuses, the plug end of the equipment or fuse panel, shall have a tag fastened to it warning not to plug back in until cleared by the maintenance person performing work on the machine or equipment. AT NO TIME shall a tag be removed from machinery or equipment without first checking with maintenance personnel or other persons working on the equipment in question.

 SAFETY & HEALTH MANUAL	Partnerships Built on Trust	14. Lockout-Tagout Program	Page 4
		Revision Date: 1/8/2024	Updated

▼ **Eliminate Stored or Residual Energy:**

Stored or residual energy may be present in piping systems, pneumatic systems, hydraulic systems and electrical systems. This stored pressure must be protected by grounding, blocking or bleeding down. Extreme caution must be exercised when removing or blocking residual energy to prevent contact with electrical sources or moving components.

Proper line breaking procedures must be followed to avoid contact with fluids or air under pressure, especially those systems that contain potentially hazardous chemicals, such as chlorine and other water treatment chemicals.

Electrical:

Caution must be exercised when working near electrical components, which are capable of storing energy. Such components include capacitors that are capable of storing high voltage for extended periods of time long after the source of electricity has been disconnected. Only qualified employees should work on electrical components or systems. Capacitors should be carefully bled to ground to remove stored energy. Generally, qualified electrical contractors will be used to perform maintenance and repair on electrical systems.

Pneumatic:

Equipment that is powered by pneumatics (air pressure) is capable of storing energy in the form of unreleased air pressure. Air cylinders on this equipment can store air pressure long after air lines and hoses have been removed and compressors shut off. This equipment could accidentally be activated with this remaining air pressure in actuating cylinders contained in the equipment. The air contained in these cylinders should be bled off, or the pump or machine should be cycled until the air has been exhausted in the cylinder.

As a rule, all air tools and hoses are to be removed from air compressors and placed in the gang box at the end of each day, no exceptions.

Hydraulic:

Equipment that is powered by hydraulics (fluid pressure) is capable of storing energy in the form of unreleased hydraulic pressure. Piping and hydraulic cylinders can store energy after hydraulic systems have been shut down. The equipment could accidentally be activated with this remaining hydraulic pressure or the servicing

 Partnerships Built on Trust SAFETY & HEALTH MANUAL	14. Lockout-Tagout Program	Page 5
	Revision Date: 1/8/2024	Updated

employee could be injured by the rapidly escaping hydraulic pressure contained in hydraulic lines and cylinders.

Any equipment or machinery that has parts operated by hydraulics, (lifts, back hoes, front end loaders, bucket trucks, excavators, tractors, etc.) should have power to the hydraulic systems turned off and the parts lowered to the ground when not in use or prior to repairs or servicing, no exceptions. This will prevent any accidental lowering of the equipment that could cause an employee to be injured if trapped by the lowered equipment. Once the power is shut off and equipment is lowered operators are to test the controls to assure they are de-energized and the equipment cannot be raised. This is to be done at the end of each work day, no exceptions.

▼ Verify Isolation of Equipment:

Isolation of the equipment must be verified by attempting to start or operate the equipment by normal starting or operating procedures. Prior to any attempt to start the equipment, first verify that no other persons are exposed to the hazard of the equipment being started. This includes checking all areas around the pump, equipment or machine to be serviced. Deactivation and isolation of the equipment shall be verified by pressing or turning start buttons and switches or other controls on the equipment. Equipment should not operate, cycle or drift when controls are operated. Once isolation of the equipment has been verified, return all operating controls and switches to the neutral or off positions.

▼ Restoring Equipment to Service:

The servicing employee or qualified contractor shall check the machine or equipment and ensure that the machine or equipment components are operationally intact including the reinstallation of all machine or equipment guarding. There should be no exposed electrical components or other hazardous moving parts such as gear drives or transmissions that could injure employees during start up. The servicing employee shall verify that all employees have been safely positioned or removed from the area when the equipment is re-energized and initially operated. Once the process equipment has been restored to service and re-energized, verify that the machine or equipment controls are in the neutral or off position or in the correct position for normal treatment plant operation.

▼ Remove Locks and Tags from Machinery and Equipment:

The servicing employee responsible for completing work on the affected machine or equipment shall be responsible for removing all locks and tags under his control. AT NO TIME shall another person remove the lock or tag from equipment being worked on by another employee. Removal of a lock or tag by a person other than the servicing

 SAFETY & HEALTH MANUAL	Partnerships Built on Trust	14. Lockout-Tagout Program	Page 6
		Revision Date: 1/8/2024	Updated

employee must be by the Beeler Construction superintendent and only after an attempt has been made to locate the original servicing employee.

▼ **Notification:**

The servicing employee or qualified contractor shall notify the Beeler Construction superintendent that maintenance or repair work has been completed on the affected equipment, machinery or vehicle and that the equipment can now be safely placed into service or operated and used. Failure of the maintenance employee to notify the operator or department that work has been completed on the equipment is a safety violation.

▼ **Subcontractors:**

Subcontractors perform all of the work covered by lockout/tagout on various facility and building machinery and equipment. All contractors are required to comply with the requirements of the Beeler Construction lockout and tagout program. Additionally, all contractors **MUST** notify Beeler Construction supervision prior to beginning work on any machinery or equipment.

Failure of a contractor to contact a supervisor will result in notification to the contractor that a violation of the lockout/tagout program has occurred. Additional violations may result in a termination of the contract or services provided by the contractor.

▼ **Enforcement of Lockout and Tagout Procedures:**

The following actions will be considered serious safety rule violations subject to disciplinary action, including possible termination:

- ✓ Removing a lock or tag from machinery or equipment unless the lock or tag being removed is their own.
- ✓ Operating or attempting to operate equipment which has been locked out or tagged out for maintenance or repair.
- ✓ Maintenance or servicing employees that do not remove their lock and tag immediately after work has been completed unless there is some specific reason that the equipment should not be returned to service.

▼ **Group Lockout/Tagout**

Each employee must affix his/her personal LOTO device to the group LOTO device prior to any servicing or maintenance operation. The supervisor in charge of the

 SAFETY & HEALTH MANUAL	Partnerships Built on Trust	14. Lockout-Tagout Program	Page 7
		Revision Date: 1/8/2024	Updated

lockout/tagout must not remove the group LOTO device until each employee in the group has removed his/her personal device.

▼ Shift Change Lockout/Tagout

The lockout/tagout supervisor or authorized employee is responsible for determining the status of each individual group member/employee. Each employee shall attach a personal LOTO device to the group's device while he/she is working and then remove it when finished. During shift changes, specific procedures will need to be developed to ensure continuity if the LOTO procedure. These specific procedures will need to be documented and recorded.

▼ Typical Lockout/Tagout Procedures for Beeler Construction Personnel:

The following is a list of typical Lockout/Tagout practices that should be followed by all Beeler Construction employees. Note Lockout/Tagout practices should not be limited to this list, there may be additional job specific requirements, and there may also be additional subcontractor specific requirements as well.

Jobsites

- Always make sure the jobsites are secure with appropriate signage requiring authorization for entry, especially in remodeling projects adjacent to public areas. Always lock-up the site at the end of each day.

Pneumatic Tools

- Always removed tools and hoses from air compressors at the end of each day or when you are done using them and store them in the jobsite gang box. Always unplug the air compressor at the end of each day or when done using it.

Electric Tools/Equipment

- Unplug all tools and extension cords at the end of each day or when you are done using them and store them in the jobsite gang box.
- Unplug all equipment at the end each day or when you are done using it, i.e. compressors, lifts, table saws, miter saws, etc.
- Always lower electric lifts to the ground, remove the keys and store them in them in the jobsite gang box or other lockable cabinet on site.
- Make a habit of lowering table saw blades below the table top at the end of each day or when you are done using the saw.
- Also make a habit of locking miter saws in the down position, also lock the miter adjustment and slides at the end of each day or when you are done using it.

 Partnerships Built on Trust SAFETY & HEALTH MANUAL	14. Lockout-Tagout Program	Page 8
	Revision Date: 1/8/2024	Updated

Hydraulic Equipment

- Any equipment or machinery that has parts operated by hydraulics, (elevators, lifts, back hoes, front end loaders, bucket trucks, excavators, tractors, etc.) should have power to the hydraulic systems turned off, parts lowered to the ground and keys removed when not in use or prior to repairs or servicing, no exceptions. This will prevent any accidental lowering of the equipment that could cause an employee to be injured if trapped by the lowered equipment. Once the power is shut off and equipment is lowered operators are to test the controls to assure they are de-energized and the equipment cannot be raised. This is to be done at the end of each work day, no exceptions. Keys are to be stored in a secure cabinet or gang box to prevent unauthorized personnel from using the equipment.

Energy Controls

- Any lockout/tagout procedures involving energy controls must be inspected annually.

SUMMARY OF LOCKOUT/TAGOUT REQUIREMENTS

- 1) **NOTIFY** the superintendent that equipment will be shut down for maintenance.
- 2) **DEACTIVATE** the machine or equipment by shutting down through normal methods.
- 3) **ISOLATE** the machine or equipment by removing the source of energy.
- 4) **LOCKOUT/TAGOUT** by placing a lock & or tag on the isolation switch or device.
- 5) **REMOVE** stored energy by grounding or bleeding residual or stored energy.
- 6) **VERIFY** isolation of equipment by attempting to start it using normal methods.
- 7) **RESTORE** equipment to normal safe operating condition including any guarding.
- 8) **REMOVE** locks and tags from affected machine or equipment.
- 9) **NOTIFY** the operator or other employee that work on the equipment is complete.

▼ **Lockout/Tagout Hardware**

Minimum guidelines for the construction and quality of devices used for lockout/tagout are listed below.

General Requirements

All lockout/tagout devices provided by the company:

- 1) Must be singularly identified (use a tag to show the identity of the employee who applies it),
- 2) Must be the only devices used for controlling energy,
- 3) Must not be used for any other purposes; do not use a Beeler padlock for lockout/tagout,
- 4) Must be capable of withstanding the environment in which they are used for the duration of use, and
- 5) Must be standardized for either color, size or shape as well as print and format

 <p>Partnerships Built on Trust</p> <p>SAFETY & HEALTH MANUAL</p>	<p>14. Lockout-Tagout Program</p>	<p>Page 9</p>
	<p>Revision Date: 1/8/2024</p>	<p>Updated</p>

Lockout Device Requirements

In addition to the above, lockout devices must be substantial enough to prevent removal without the use of excessive force or unusual means.

Tagout Device Requirements

In addition to the above, tagout devices:

- 1) Must not deteriorate when used in corrosive environments,
- 2) Must not deteriorate or become illegible upon exposure to weather conditions or use in damp locations,
- 3) Must warn against hazardous conditions if the machine or equipment is energized, including a warning such as “Do Not Operate”, and
- 4) Must be substantial enough to prevent inadvertent or accidental removal; the means of attachment must be non-reusable, self-locking, attachable by hand and capable of withstanding 50 pounds of pull (e.g., one piece of nylon cable tie).

▼ Periodic Inspection

The Beeler Construction foreman/superintendent and the safety director are responsible for periodically inspecting the proper application of the lockout/tagout procedure and policy. Deficiencies will be immediately corrected and employees will be retrained, as appropriate. The inspection form on the following page is to be used to record and document the periodic inspections.

 <p>Partnerships Built on Trust</p> <p>SAFETY & HEALTH MANUAL</p>	<p>14. Lockout-Tagout Program</p>	<p>Page 10</p>
	<p>Revision Date: 1/8/2024</p>	<p>Updated</p>

**BEELER CONSTRUCTION, INC.
LOCKOUT/TAGOUT PERIODIC INSPECTION**

Scope: OSHA Standard 1910.147, The Control of Hazardous Energy (Lockout/Tagout) requires the employer to conduct a periodic inspection of the Lockout/Tagout procedure. The inspection must be at least annually for all authorized employees to ensure that the procedures and requirements of the standard are being followed.

Job Name: _____

Name of Equipment Isolated: _____

Location Within Facility: _____

Signature of Employee(s) Performing Lockout/Tagout:

Name of Employee(s) Interviewed:

Classification:

Is the procedure being followed properly?	€ Yes	€ No
Is there a padlock for each exposed worker?	€ Yes	€ No
Are all the energy source(s) locked and tagged out?	€ Yes	€ No
Is an electrically safe work condition established?	€ Yes	€ No
Is a category rated voltage detector used properly?	€ Yes	€ No
Is a voltage detector tested before and after to confirm proper operation?	€ Yes	€ No
Are grounding cables used where appropriate?	€ Yes	€ No
Were the employee's responsibilities under the energy control procedures reviewed?	€ Yes	€ No

List of concerns that were re-emphasized to employees:

Corrective action taken for deviations or inadequacies of procedure:

Completed by: _____

Date: _____

Title: _____

 Partnerships Built on Trust	15. Confined Space	Page 1
	Revision Date: 1/8/2024	Updated
SAFETY & HEALTH MANUAL		

Confined Space Entry Program

PURPOSE: The purpose of Beeler Construction’s Confined Space Entry Program is to prevent injury to employees during entry into confined spaces. This policy establishes procedures for safe entry and complies with OSHA’s Permit Required Confined Space Standard 29 CFR 1910.146.

POLICY: Beeler Construction provides a safe and healthful workplace for all of its employees and subcontractors. It is the policy of Beeler Construction to provide requirements for the evaluation and safe entry into all confined spaces likely to be encountered during construction and other site activities.

TRAINING: All Beeler Construction employees shall receive initial confined space training and annual refresher training. Prior to working in a confined space, affected employees will receive confined space training specific to that work assignment. In the event the employee’s assigned duties change or in the even a new hazard has been created or deviations have occurred, additional training will be provided/required prior to re-entry into a confined space. All training must be documented; records shall include employee names, trainer signature/initials and dates of training. Training records must be maintained and made available to employees and their authorized representatives.

▼ DEFINITIONS:

Confined Space:

Any space that has limited or restricted means of entry/exit; is large enough for a person to enter; is not designed for continuous occupancy.

Types of confined space include but are not limited to:

- | | | |
|--------------|----------|-----------|
| Tanks | Vessels | Silos |
| Storage Bins | Hoppers | Vaults |
| Pits | Manholes | Tunnels |
| Cupolas | Furnaces | Pipelines |
| Crawlspaces | | |

Before work begins at the site, Beeler Construction and each subcontractor/employer must ensure that a competent person has reviewed and identified all confined spaces where work may occur. Beeler Construction’s site supervisor will be considered their competent person; each subcontractor involved with a confined space must identify their competent person prior to beginning work.

Non-Permit Required Confined Space:

A confined space that does not contain or, with respect to atmospheric hazards, have the potential to contain any hazard capable of causing death or serious physical harm.

 Partnerships Built on Trust SAFETY & HEALTH MANUAL	15. Confined Space	Page 2
	Revision Date: 1/8/2024	Updated

Alternate Procedure Confined Space:

A confined space that contains only a hazardous atmosphere, or the potential for a hazardous atmosphere, that can be controlled through the use of forced air ventilation used prior to and during the confined space entry operation. Alternate procedure confined spaces may not contain hazards other than that of a hazardous or potentially hazardous atmosphere.

Permit-Required Confined Space:

A confined space that contains or has known potential to contain a hazardous atmosphere; and has the potential for engulfing or entrapping the entrant; and/or has an internal configuration that could trap or asphyxiate the entrant: and/or contains other recognized safety or health hazards.

Hazardous Atmosphere:

An atmosphere that may expose employees to risk of death, incapacitation,, impairment of ability to self-rescue, injury, or acute illness from one of the following; flammable gas, vapor or mist in excess of 10% of its lower flammable limit, airborne combustible dust at a concentration that meets or exceed its lower flammable limit, atmospheric oxygen below 19.5% of above 23.5%, any atmospheric concentration of any substance listed in OSHA 29 CFR 1926 Subpart D and Z, which could result in an employee exposure in excess of its dose or permissible exposure limit, or any other atmospheric conditions that is immediate dangerous to life or health. Examples of toxins commonly found in confined spaces include vapors or gases that may be present in laboratories within buildings, carbon monoxide, methane in manholes, trenches or sewers, lack of oxygen in manholes, trenches or sewers , etc.

Entry Supervisor:

The employee responsible for evaluating and authorizing all confined space entry operations and for signing permits for entries into permit-required confined spaces. This employee has the authority to terminate all confined space entries if conditions in the confined space change or present an increased hazard to the entrants. In most situations, the Beeler Construction supervisor will perform the duties of entry supervisor.

Attendants:

Attendants are required to be present at all times during permit-required confined space entries. The entry supervisor shall ensure that the primary duty of the attendant(s) is the monitoring of entrants. Attendants can also act as helpers by handling tools, equipment and materials to employees within the space as long as those secondary responsibilities do not distract or remove the attendants from the confined space entrance for more than a few moments.

Entrants:

Entrants must be trained and know the hazards they may face during entry, including information on the mode, signs or symptoms and consequences of the exposure. Entrants must communicate with the attendant as necessary to enable the attendant to monitor entrant status and to enable the attendant to alert entrants of the need to evacuate space. Entrants must alert the attendant whenever: the entrant recognizes any warning sign or symptom of exposure to a dangerous situation, or detects a prohibited condition. Entrants must exit a confined space whenever: an order of evacuate is given by the attendant of entry supervisor, the entrant recognizes any warning sign or symptom of exposure to a dangerous situation, the entrant detects a prohibited condition or an evacuation alarm is activated.

 Partnerships Built on Trust	15. Confined Space	Page 3
	SAFETY & HEALTH MANUAL	Revision Date: 1/8/2024

Multiple Entrants/Employers:

In the event multiple entrants from different employers are working in the same confined space, strict coordination is required between entrants. Prior to entry, a coordination meeting is required between all entrants, the attendant and the entry supervisor. All work processes, materials and equipment used will be discussed in detail and will be noted on the entry permit. This is to ensure that entrants from one employer are not endangering entrants from other employers.

IDLH Conditions:

Beeler Construction employees and subcontractor employees working for Beeler Construction are to NEVER enter confined spaces subject to IDLH (Immediately Dangerous to Life or Health) under any circumstances.

Yearly Confined Space Program Review:

Beeler Construction requires a yearly review of all confined space operations performed. All cancelled permits are to be retained for the year and reviewed for their effectiveness. Any deficiencies should be corrected and the confined space program should be revised accordingly. The yearly review should include the site supervisors, project managers and Beeler Construction’s safety director.

Isolation:

The process by which a permit space is removed from service and completely protected against the release of energy and material into the space by such means as blanking or blinding, misaligning or removing sections of lines, pipes or ducts; a double block and bleed system; lockout/tagout of all sources of energy; or blocking or disconnecting all mechanical linkages.

▼ Confined Space Entry Evaluation:

Beeler Construction has performed an evaluation of the types of confined spaces that may be encountered in construction operations. This evaluation has determined that confined spaces being entered are non-permit, alternate procedure and permit-required confined spaces. The types of confined spaces entered by subcontractor’s employees may include new or active storm system inlets and manholes, new or active sanitary system manholes, underground vaults, and some excavations. Most of these spaces typically have limited means of entry and exit, are large enough to enter, and are not designed for continuous employee occupancy. Therefore, these spaces described above meet the definition of a confined space.

▼ Non-Permit Confined Spaces:

Evaluation and subsequent determination of a non-permit confined space may be based on knowledge of the space concerning the potential that exists for a hazardous atmosphere or other hazards that may be present in the space. Generally a determination that a non-permit confined space exists **MUST** be based upon atmospheric testing conducted using a properly calibrated gas detector and the verification that no other hazards exist within the confined space. Other hazards may include additional potential hazards such as engulfment, entrapment, drowning, and exposure to moving or energized electrical equipment, etc.

 Partnerships Built on Trust	15. Confined Space	Page 4
	SAFETY & HEALTH MANUAL	Revision Date: 1/8/2024

In some limited situations, non-permit confined spaces may be determined by a specific knowledge of the confined space and the potential for atmospheric hazards. Examples of non-permit confined spaces include:

- ✓ Entry into new manholes **not yet connected** to existing storm or sanitary systems.
- ✓ Entry into the majority of excavations and trenches where the potential for a hazardous atmosphere does not or cannot exist.

It must be demonstrated that no potential for a hazardous atmosphere exists in the confined space. For example, if the excavation used in the example above was located in close proximity to heavily traveled roads where carbon monoxide could migrate and accumulate in the space, then the space must be classified as at least an alternate procedure confined space. If the Beeler Construction entry supervisor is unsure of the status or potential status of any confined space that needs to be entered, then atmospheric testing must be performed to verify that a space is truly a non-permit confined space.

▼ **Non-Permit Confined Space Entry Procedures:**

Physical Protection of Work Area:

The entry supervisor will ensure that employees are protected from vehicular traffic and pedestrians are protected from confined space entry activities by properly barricading the area where confined space entry activities are conducted.

Safe Removal of Covers:

Employees engaged in the removal of any covers to the confined space must use caution in the removal of the cover to avoid creating sparks which could cause an explosion of gases contained within the space or removal of a cover from a confined space which is under pressure. Covers may be heavy and may require the assistance of another employee to avoid injuries caused as a result of lifting or carrying a cover.

The entry supervisor shall ensure that testing is performed on manhole covers with holes that allow the insertion of the gas detector hose to determine if a flammable atmosphere exists prior to removal of the cover to prevent sparks and potential ignition of gases in the space.

Guarding & Posting Signs at Entry to Confined Space:

The entry supervisor shall ensure that a railing, temporary cover or other barrier is placed near or around the entrance or opening to protect employees from falling through the opening and to protect entrants from materials and debris that could fall into the opening during the entry.

Atmospheric Testing:

Employees trained in the use of atmospheric testing instrumentation shall test the atmosphere of the confined space prior to entry to determine the presence of a hazardous atmosphere. Contaminants or potential hazards within the confined space shall be tested in the following order:

- 1) Oxygen
- 2) Flammable Gas or Vapor
- 3) Toxic Materials (gasoline vapor, diesel vapor, etc.)

 Partnerships Built on Trust	15. Confined Space	Page 5
	SAFETY & HEALTH MANUAL	Revision Date: 1/8/2024

Instrumentation should be calibrated by a properly trained person prior to use each day or according to the manufacturer's instructions.

For purposes of entry into alternate permit confined spaces, the atmosphere must contain 20.9% oxygen, 0% lower explosive limit for flammables, and 0 ppm toxic gases or vapors. Readings on most meters vary and fluctuate slightly, but in no case should entry be permitted if instrumentation indicates that a hazardous atmosphere may be present.

If a hazardous atmosphere exists after testing the confined space, the entry supervisor shall classify the space as an alternate procedure or permit-required confined space using the procedures that follow.

Lockout and Tagout:

Prior to any entry into a confined space, the entry supervisor shall ensure that all sources of energy or material flow into the confined space have been identified. This will be accomplished by reviewing drawings or discussions with the owner, general contractor or municipality. If drawings are not available, the entry supervisor shall attempt to determine all possible sources of energy and material flow.

Once these sources of energy or material flow have been identified, the entry supervisor shall take the necessary precautions to isolate, remove or lockout such potentially hazardous sources from the confined space. Such actions may involve the closing and locking of valves connected to the confined space, placement of plugs or blocks in piping, the disconnection of piping and blanking of piping connected to the confined space, the opening and locking of switches where electrically operated devices are located within a confined space or operating pumps that could flow materials into the confined space, etc.

Confined Space Re-Classification:

If conditions change within the space that increase the hazard to the entrants, the entry supervisor shall terminate the entry and re-classify the space as either alternate procedure confined space or full permit-required confined space.

▼ Alternate Procedure Confined Spaces:

Permit-required confined spaces may be classified as an alternate procedure permit-required confined space if the entry supervisor determines that the only hazard with the confined space is that of a hazardous or potentially hazardous atmosphere. No other hazards, such as the hazard of engulfment or the hazards of moving equipment can exist in the space classified as an alternate procedure confined space. Employees within alternate procedure confined spaces must be capable of self-rescue. If employees within a space are not capable of self-rescue, the space shall be classified as a permit-required confined space. Examples of typical alternate procedure confined spaces include:

- ✓ Entry into active storm system inlets and manholes that have plugs placed in pipes flowing into the manhole.
- ✓ Entry into underground vaults where the interior configuration can impair escape from within the space.
- ✓ Entry into excavations where ventilation can eliminate a hazardous atmosphere.

 Partnerships Built on Trust SAFETY & HEALTH MANUAL	15. Confined Space	Page 6
	Revision Date: 1/8/2024	Updated

If the entry supervisor determines that a confined space has only a hazardous atmosphere or potential for hazardous atmosphere, then the following procedure shall be used prior to entry by any employee:

Physical Protection of Work Area:

The entry supervisor will ensure that employees are protected from vehicular traffic and pedestrians are protected from confined space entry activities by properly barricading the area where confined space entry activities are conducted.

Safe Removal of Covers:

Employees engaged in the removal of any covers to the confined space shall use caution in the removal of the cover to avoid creating sparks which could cause an explosion of gases contained within the space or removal of a cover from a confined space which is under pressure. Covers may be heavy and may require the assistance of another employee to avoid injuries caused as a result of lifting or carrying a cover.

The entry supervisor shall ensure that testing is performed on manhole covers with holes that allow the insertion of the gas detector hose to determine if a flammable atmosphere exists prior to removal of the cover to prevent sparks and potential ignition of gases in the space.

Guarding & Posting Signs at Entry to Confined Space:

The entry supervisor shall ensure that a sign “DANGER-PERMIT REQUIRED CONFINED SPACE, DO NOT ENTER” is posted near the entrance to the confined space. The entry supervisor shall also ensure that a railing, temporary cover or other barrier is placed near or around the entrance or opening to protect employees from falling through the opening and to protect entrants from materials and debris that could fall into the opening during the entry.

Atmospheric Testing:

Atmospheric testing should **ALWAYS** be performed prior to ventilation of the confined space. The entry supervisor must know if hazards existed in the space prior to ventilation in order to anticipate increases in the hazards within the space.

Employees trained in the use of atmospheric testing instrumentation shall test the atmosphere of the confined space prior to entry to determine the presence of a hazardous atmosphere. Contaminants or potential hazards within the confined space shall be tested in the following order:

- 1) Oxygen
- 2) Flammable Gas or Vapor
- 3) Toxic Materials (gasoline vapor, diesel vapor, etc.)

Instrumentation should be calibrated by a properly trained person prior to use each day, or according to the manufacturer’s instructions.

For purposes of entry into alternate permit confined spaces, the atmosphere must contain 20.9% oxygen, 0% lower explosive limit for flammables, and 0 ppm toxic gases or vapors. Some meters may vary slightly, but in no case should entry be permitted if instrumentation indicates that a hazardous atmosphere may be present, unless the use of forced air ventilation can control and reduce the hazardous atmosphere to acceptable limits.

 Partnerships Built on Trust	15. Confined Space	Page 7
	SAFETY & HEALTH MANUAL	Revision Date: 1/8/2024

There may be no hazardous atmosphere within the space whenever any employee is inside the confined space. If a hazardous atmosphere is detected while an employee is in the space, the entrants shall be ordered to leave the space and the confined space must be re-classified as a full permit-required confined space by the entry supervisor.

The atmosphere within the space must be continuously monitored throughout the entry to ensure that the continuous forced air ventilation is preventing the accumulation of a hazardous atmosphere. Continuous monitoring may be conducted from either inside or outside of the space, preferably outside the space by an authorized attendant.

Lockout and Tagout:

Prior to any entry into a confined space, the entry supervisor shall ensure that all sources of energy or material flow into the confined space have been identified. This will be accomplished by reviewing drawings or discussions with the owner, municipality, or other party. If drawings are not available, the entry supervisor shall attempt to determine all possible sources of energy and material flow.

Once these sources of energy or material flow have been identified, the entry supervisor shall take the necessary precautions to isolate, remove or lockout such potentially hazardous sources from the confined space. Such actions may involve the closing and locking of valves connected to the confined space, placement of plugs or blocks in piping, the disconnection of piping and blanking of piping connected to the confined space, the opening and locking of switches where electrically operated devices are located within a confined space or operate pumps that could flow materials into the confined space, etc.

Ventilation:

Continuous, forced ventilation must be provided for entry into alternate procedure confined spaces. Employees may not enter the space until the forced air ventilation has eliminated the hazardous atmosphere. Forced air ventilation must be designed to ventilate the immediate areas where employees are working within the space and must continue until all employees have left the space.

The entry supervisor should survey the work area to determine the best location for placement of ventilation equipment. The ventilator should be placed far enough away from the entrance to the confined space to prevent the recirculation of gases and vapors back into the space. Care must also be taken to locate the ventilator upwind of any equipment that produces exhaust and carbon monoxide.

If any liquids have been removed from the confined space, potentially hazardous vapors and gases must be removed prior to entry by providing adequate ventilation of the confined space. Caution must be taken during the removal and ventilation of confined spaces so as not to create a greater hazard. Removal and ventilation of flammable liquids and vapors can create static charges which can ignite flammable vapors inside or outside the space.

 Partnerships Built on Trust	15. Confined Space	Page 8
	Revision Date: 1/8/2024	Updated

SAFETY & HEALTH MANUAL

Permit Completion:

The entry supervisor shall prepare and sign a permit authorizing entry into an alternate permit-required confined space. This permit shall be kept near the entrance to the confined space. The permit shall contain results of initial atmospheric testing, a description of the ventilation system used, and isolation methods used to eliminate the hazard of mechanical or electrical equipment or flow of materials into the space. The permit is valid only for the duration of the work shift or 24 hours, whichever is shorter. The permit system at the end of this procedure shall be used.

Attendants:

Attendants are not required during entry into alternate procedure confined spaces; however, the entry supervisor may require the use of an attendant if rescue considerations from the space indicate the potential need for an attendant. Such considerations may include the depth of the space being entered, the need to communicate to other employees outside the confined space, the need for a person to be available to hand materials, tools and equipment to the entrants, etc.

Training:

The entry supervisor shall ensure that all entrants have been properly trained in the hazards of the confined space, methods used to evaluate atmospheric conditions within the alternate procedure confined space, emergency procedures to be used in the event evacuation from the space becomes necessary and the use and application of this procedure and permit system.

Confined Space Re-Classification:

If conditions change within the space that increases the hazard to the entrants, the entry supervisor shall terminate the entry and re-classify the space as a full permit-required confined space.

▼ Permit-Required Confined Spaces:

Prior to entry into any permit required confined space, an Entry Permit **MUST** be completed by Entry Supervisor, **NO EXCEPTIONS**. A sample of Beeler Construction’s Entry Permit is included at the end of this section.

If the entry supervisor determines that the hazards within the confined space cannot be controlled through the use of forced air ventilation, or that additional non-atmospheric hazards exist within the space, then the confined space shall be handled as a permit-required confined space. If the entry supervisor determines that an alternate procedure confined space prohibits employees from self-rescue, the space shall be classified as a permit-required confined space. Examples of typical permit-required confined spaces include:

- ✓ Entry into active storm system inlets or manholes
- ✓ Entry into tanks where interior baffles prevent escape
- ✓ Entry into excavations where a hazardous atmosphere exists and flow of water or other material into the excavation creates a drowning hazard

If the entry supervisor determines that a permit-required confined space exists, the following procedures shall be followed prior to entry by any employee.

 Partnerships Built on Trust	15. Confined Space	Page 9
	Revision Date: 1/8/2024	Updated

SAFETY & HEALTH MANUAL

Physical Protection of Work Area:

The entry supervisor will ensure that employees are protected from vehicular traffic and pedestrians are protected from confined space entry activities by properly barricading the area where confined space entry activities are conducted.

Safe Removal of Covers:

Employees engaged in the removal of any covers to the confined space shall use caution in the removal of the cover to avoid creating sparks which could cause an explosion of gases contained within the space; or removal of a cover from a confined space which is under pressure. Covers may be heavy and may require the assistance of another employee to avoid injuries caused as a result of lifting or carrying a cover.

The entry supervisor shall ensure that testing is performed on manhole covers with holes that allow the insertion of the gas detector hose to determine if a flammable atmosphere exists prior to removal of the cover to prevent sparks and potential ignition of gases in the space.

Guarding & Posting Signs at Entry to Confined Space:

The entry supervisor shall ensure that a sign “DANGER – PERMIT REQUIRED CONFINED SPACE, DO NOT ENTER” is posted near the entrance to the confined space. The entry supervisor shall also ensure that a railing, temporary cover, or other barrier is placed near or around the entrance or opening to protect employees from falling through the opening and to protect entrants from materials and debris that could fall into the opening during the entry.

Atmospheric Testing:

Atmospheric testing should **ALWAYS** be performed prior to ventilation of the confined space. The entry supervisor must know if hazards existed in the space prior to ventilation in order to anticipate increases in the hazards within the space.

Employees trained in the use of atmospheric testing instrumentation shall test the atmosphere of the confined space prior to entry to determine the presence of a hazardous atmosphere. Contaminants or potential hazards within the confined space shall be tested in the following order:

- 1) Oxygen
- 2) Flammable Gas or Vapor
- 3) Toxic Materials (gasoline vapor, diesel vapor, etc.)

Instrumentation should be calibrated by a properly trained person prior to use each day or according to the manufacturer’s instructions.

For purposes of entry into alternate permit confined spaces, the atmosphere must contain 20.9% oxygen, 0% lower explosive limit for flammables, and 0 ppm toxic gases or vapors. Some meters may vary slightly, but in no case should entry be permitted if instrumentation indicates that a hazardous atmosphere may be present, unless the use of forced air ventilation can control and reduce the hazardous atmosphere to acceptable limits.

 Partnerships Built on Trust	15. Confined Space	Page 10
	Revision Date: 1/8/2024	Updated
SAFETY & HEALTH MANUAL		

There may be no hazardous atmosphere within the space whenever any employee is inside the confined space, unless the employee uses an airline respirator equipped with an emergency escape bottle. No employee shall be allowed to enter or remain in a confined space when the concentration of flammable gases or vapors exceeds 10% of the lower explosive limit for the material. If a hazardous atmosphere is detected while an employee is in the space, the entrants shall be ordered to leave the space until the hazardous atmosphere within the space is eliminated through increased ventilation or isolation methods. The entry supervisor must verify that the hazardous atmosphere has been eliminated through additional atmospheric testing that is documented on the permit form.

The atmosphere within the space must be continuously monitored throughout the entry to ensure that the continuous forced air ventilation is preventing the accumulation of a hazardous atmosphere. Continuous monitoring may be conducted from either inside or outside of the space, preferable outside the space by an authorized attendant.

Lockout and Tagout:

Prior to any entry into a confined space, the entry supervisor shall ensure that all sources of energy or material flow into the confined space have been identified. This will be accomplished by reviewing drawings or discussions with the owner, general contractor or municipality. If drawings are not available, the entry supervisor shall attempt to determine all possible sources of energy and material flow.

Once these sources of energy or material flow have been identified, the entry supervisor shall take the necessary precautions to isolate, remove or lockout such potentially hazardous sources from the confined space. Such actions may involve the closing and locking of valves connected to the confined space, placement of plugs or blocks in piping, the disconnection of piping and blanking of piping connected to the confined space, the opening and locking of switches where electrically operated devices are located within a confined space or operate pumps that could flow materials into the confined space, etc.

Ventilation:

Continuous forced ventilation must be used for entry into permit-required confined spaces unless conditions require entry into the space with self-contained breathing apparatus or air-supplied respirators with emergency escape bottles. Employees may not enter the space until the forced air ventilation has eliminated the hazardous atmosphere. Forced air ventilation must be designed to ventilate the immediate areas where employees are working within the space and must continue until all employees have left the space.

The entry supervisor should survey the work area to determine the best location for placement of ventilation equipment. The ventilator should be placed far enough away from the entrance to the confined space to prevent the recirculation of gases and vapors back into the space. Care must also be taken to locate the ventilator upwind of any equipment that produces exhaust and carbon monoxide.

If any liquids have been removed from the confined space, potentially hazardous vapors and gases must be removed prior to entry by providing adequate ventilation of the confined space. Caution must be taken during the removal and ventilation of confined spaces so as not to create a greater hazard. Removal and ventilation of flammable liquids and vapors can create static charges which can ignite flammable vapors inside or outside the space.

 Partnerships Built on Trust	15. Confined Space	Page 11
	Revision Date: 1/8/2024	Updated

SAFETY & HEALTH MANUAL

Attendants:

Attendants are required to be present at all times during permit-required confined space entries. The entry supervisor shall ensure that the primary duty of the attendant(s) is the monitoring of entrants. Attendants can also act as helpers by handing tools, equipment and materials to employees within the space as long as those secondary responsibilities do not distract or remove the attendants from the confined space entrance for more than a few moments.

The attendants must be trained in the rescue procedures that may become necessary during the confined space entry. Wherever possible, attendants should attempt to use non-entry rescue techniques to remove entrants from the space. These methods are described below.

Attendants are not allowed to simultaneously monitor multiple confined spaces. Each confined space must have a separate attendant.

Communications:

The entry supervisor shall ensure that attendants can effectively communicate with entrants of the confined spaces. Attendants should maintain visible and audible contact with the entrants. Radios may be required if the attendants cannot effectively communicate with entrants.

Emergency Equipment and Rescue:

The entry supervisor shall ensure that attendants are instructed to NEVER enter the confined space to affect a rescue, unless the attendants have been properly trained, equipped and drilled in confined space entry rescue.

The entry supervisor shall ensure that adequate emergency rescue equipment is available and set up prior to entry in the confined space. When trained rescue personnel are not available for rescue within the confined space, the entry supervisor shall ensure that each entrant is equipped with a full body harness and a “D” ring located at the back near the shoulder level and that the end of the retrieval line is securely attached to an approved winch/tripod for rescue from vertical spaces greater than 5 feet deep.

Any full body harness or mechanical retrieval device which is used to arrest the fall of an employee being lowered into, or removed from a confined space, shall be removed from service immediately and tested and re-certified by the manufacturer.

If non-entry rescue from a confined space is not possible, the entry supervisor shall ensure that at least two attendants are available to perform entry rescue. If it becomes necessary to enter the confined space to rescue the entrant, one of the attendants will wear an airline respirator with escape bottle and enter the space to rescue the entrant.

The attendant shall rescue the entrant by assisting the entrant out of the space, if the entrant is conscious and capable of being assisted or through the use of a body harness, wristlets or other extrication equipment necessary to remove the entrant from the space. The second attendant shall remain at the entrance to the confined space and monitor the activities of the rescuer and the victim. If the rescuer in the confined space becomes a second victim, the second attendant shall summon outside assistance by calling 911 or the nearest available fire department rescue team.

 Partnerships Built on Trust	15. Confined Space	Page 12
	SAFETY & HEALTH MANUAL	Revision Date: 1/8/2024

Permit Completion:

The entry supervisor shall prepare and sign a permit authorizing entry into a permit-required confined space. This permit shall be posted at the portal to the confined space. The permit shall contain results of initial atmospheric testing, a description of the ventilation system used, isolation methods used to eliminate the hazard of mechanical or electrical equipment, or flow of materials into the space. The permit is valid only for the duration of the work shift or 24 hours, whichever is shorter. The permit in the appendix to this procedure shall be used.

Training:

The entry supervisor shall ensure that all entrants and attendants have been properly trained in the hazards of the permit-required confined space, methods used to evaluate atmospheric conditions within the confined space, emergency procedures to be used in the event evacuation from the space becomes necessary and the use and application of this procedure and permit system.

Confined Space Re-Classification:

If conditions change within the space, which increase the hazard to the entrants, the entry supervisor shall terminate the entry and re-evaluate entry into the confined space. Examples of conditions which could cause termination of entry could be uncontrolled atmospheric hazards detected by continuous monitoring or the existence of additional hazards such as the rise in the level of water or materials in the space which present a hazard to the entrant.

▼ Completion of Confined Space Entry Operations:

Upon completion of all work within confined spaces, the entry supervisor will ensure that the following actions have been completed:

- 1) All entrants have safely evacuated the confined space.
- 2) Debriefing entrants and attendants related to conditions within the space.
- 3) All tools and equipment have been removed from the confined space.
- 4) The confined space has been properly closed or secured.
- 5) The permit form has been canceled and signed.
- 6) The canceled permit is returned to Public Works main office for filing.

▼ Confined Space Entry Procedure Review:

If the entry supervisor discovers at the conclusion of the entry that the procedure does not fully address all hazards revealed during the entry, the entry supervisor should contact the main office immediately and a review and revision of the procedure will be completed prior to the next Beeler Construction confined space entry.

Confined Space Permit

Why can't this be considered an Alternative Entry? _____

It is company policy NOT to enter into a confined space when Atmospheric hazards are not controllable

Location: _____ **Type of Space:** Sewer Other: _____

Reason for Entry: _____

Note: This permit SHALL be posted at the entry point "Per OSHA"

Atmospheric Hazards: <input type="checkbox"/> Oxygen deficiency (less 19.5) <input type="checkbox"/> Oxygen enrichment (Greater 23.5%) <input type="checkbox"/> Combustible gas <input type="checkbox"/> Flammable gas (below 10%) <input type="checkbox"/> Toxic contaminants <input type="checkbox"/> Other: _____ <i>If atmospheric hazards are not controllable "Do not enter" the confined space</i>	Physical Hazards: <input type="checkbox"/> Mechanical <input type="checkbox"/> Electrical <input type="checkbox"/> Heat <input type="checkbox"/> Chemical/Biological <input type="checkbox"/> High Noise <input type="checkbox"/> Low visibility <input type="checkbox"/> Long distance to exit <input type="checkbox"/> Slips, trips and falls <input type="checkbox"/> Other: _____	Hazard Controls: <input type="checkbox"/> Ventilation <input type="checkbox"/> Lockout/Tagout <input type="checkbox"/> Personal Protective Equipment <input type="checkbox"/> Chemical/Biological <input type="checkbox"/> Purging <input type="checkbox"/> Barriers/Guardrails <input type="checkbox"/> Fall Protection <input type="checkbox"/> Other: _____ <i>The policy will not require workers to enter a confined space if respirators are required.</i>
---	---	--

Date: _____	Time Entering: _____	Time Canceled: _____ Why Canceled: _____
--------------------	-----------------------------	---

Estimate Time of Entry Operations: _____ (When time is expired permit is canceled and operation shall cease)

Employee Signatures: (Entering= E) (Attendant= A) (Trained to Enter=T)

1. _____ <input type="checkbox"/> E <input type="checkbox"/> A <input type="checkbox"/> T	2. _____ <input type="checkbox"/> E <input type="checkbox"/> A <input type="checkbox"/> T	3. _____ <input type="checkbox"/> E <input type="checkbox"/> A <input type="checkbox"/> T
4. _____ <input type="checkbox"/> E <input type="checkbox"/> A <input type="checkbox"/> T	5. _____ <input type="checkbox"/> E <input type="checkbox"/> A <input type="checkbox"/> T	6. _____ <input type="checkbox"/> E <input type="checkbox"/> A <input type="checkbox"/> T
7. _____ <input type="checkbox"/> E <input type="checkbox"/> A <input type="checkbox"/> T	8. _____ <input type="checkbox"/> E <input type="checkbox"/> A <input type="checkbox"/> T	9. _____ <input type="checkbox"/> E <input type="checkbox"/> A <input type="checkbox"/> T

Atmospheric Testing (Gas monitor shall be inside the confined space & continuously monitoring the air quality)

Date of Monitor Last Calibration: _____ **Type of Gas Monitor:** _____

Pre-Entry Testing Time Tested: _____ Oxygen _____ CO2 _____ LEL _____ H2S _____ <i>If any of the above is present in the space, DO NOT Enter. Contact management and owner of the confined space</i>	Continues Testing Time Ended Testing: _____ Oxygen _____ CO2 _____ LEL _____ H2S _____ <i>If detected exit space! Enter the reading(s).</i> Tester's Signature: _____
--	--

Ventilation Equipment (Provide continues ventilation)

Type: Forced Exhausted Confined Space Blower CFM: _____ Confined Space Size: _____
 Estimated Approximate Purge Time: _____

Communication Procedures

Radio Visual Voice Rope Signal Phone Other : _____

PPE: Coveralls Tyvek® suit Leather gloves Chemical resistant gloves Eye protection Hard Hat
 Hearing protection Safety shoes/boots Harness/lifeline & Tripod/winch Other: _____

Traffic Control: Barricades Vests Flags Signs

Rescue Team Phone Number: _____ **Rescue Team Name and address:** _____
 _____ **Name of Person Who Was Contacted:** _____

I Assume The Responsibility of The Entry Supervisor and Approve This Permit:

Entry Supervisor (Print): _____ **Sign:** _____

Date: _____ **Time:** _____ *Note: Use the back side for any comments*

DANGER

FOLLOW

CONFINED SPACE

ENTRY PROCEDURES

BEFORE ENTERING

 <p>Partnerships Built on Trust</p> <p>SAFETY & HEALTH MANUAL</p>	<p>16. Forklift & Industrial Safety</p>	<p>Page 1</p>
	<p>Revision Date: 1/8/2024</p>	<p>Updated</p>

Forklift & Industrial Lift Safety

PURPOSE: The purpose of this policy is to provide Beeler Construction employees and management with the information necessary for the safe and proper use of forklifts and industrial lifts.

POLICY: Beeler Construction provides a safe and healthful workplace for all of its employees. All employees must become familiar with the following Forklift and Industrial Lift Safety program. This program has been developed to comply with OSHA 29 CFR 1910.147.

TRAINING: All Beeler Construction employees shall receive initial training regarding forklift and industrial lifts use, further refresher training will be provided periodically. Employees who have been trained for the use of forklifts will receive an Operator's License upon completion of the training. Training shall include formal training and practical hands on operational training by a qualified instructor. Operators must renew these licenses prior to expiration date; refresher training is required every three years. Workplace specific training with operator evaluation will be also be provided as needed. All training shall be documented with employee name, training date and name of trainer recorded.

PROCEDURES:

▼ Safe Operating Practices:

Prior to operation or at the beginning of each shift, review/confirm planned use and needed functions, assess work conditions and document the following:

- 1) Check the work area for hazards and remove/control them prior to operation.
- 2) Only use a truck designed to safely work in the work-area observed.
- 3) Review operating instructions, warnings and precautions for the types of truck being operated.
- 4) Remember the differences between the lift-truck drive-train/steering and an automobile.
- 5) Review truck controls and instrumentation. Where are they located, what do they do and how do they work?
- 6) Check engine or motor operation.
- 7) Assure safety systems are working properly, i.e., horn, backing alarm, warning lights, etc.
- 8) Check steering and maneuvering as being sound and solid.
- 9) Familiarize yourself with visibility (including restrictions due to loading and truck components).
- 10) Review fork and attachment adaptation, operation and use limitations.
- 11) Review vehicle capacity and vehicle stability.



Partnerships
Built on Trust

SAFETY & HEALTH MANUAL

16. Forklift & Industrial Safety

Page

2

Revision Date: 1/8/2024

Updated

- 12) Complete vehicle inspection and maintenance that the Operator is required to perform.
- 13) Check fuel and/or charging and recharging of batteries and refuel/recharge as needed.
- 14) Review Lift Truck operating limitations.
- 15) Review other operating instructions, warnings, or precautions listed in the operator's manual for the types of vehicle that the operator will operate.
- 16) Alert all persons in the work area of intended work activities and hazards.

▼ Securing the Load:

- 1) Always place the load against the backrest to help stabilize the load.
- 2) Always place the larger or heaviest part of the load closest to the backrest.
- 3) If carrying wide loads such as lumber or steel, adjust the forks as wide as possible.
- 4) Use ropes or straps to secure the load as needed; only attach to the backrest extension or apron carriage.
- 5) Use clamps or wood blocks to keep round objects such as pipes from rolling during transport.
- 6) Never have a person walk in front of the forklift to stabilize a load while the forklift is being driven.
- 7) Use shrink wrap or tape as needed to secure items stacked on pallets.

▼ Conducting the Lift/Carry:

- 1) Always evaluate the situation before making a lift.
- 2) Always pickup an object with the heaviest side against the backrest.
- 3) If the load is too large to see around, always drive in reverse.
- 4) Never allow a person to walk or stand between the lift truck/load and another object.
- 5) Always carry the load as low as possible and watch for overhead obstructions.
- 6) Always honk the horn at intersections, blind spots, corners, or where pedestrians are near.



Partnerships
Built on Trust

SAFETY & HEALTH MANUAL

16. Forklift & Industrial Safety

Page

3

Revision Date: 1/8/2024

Updated

▼ Types of Lifts:

Electric Pallet Jack – An electric powered lift that the operator walks behind that is made for carrying palletized material. It is designed to lift the load 6" or less and not for stacking or placing the load up into storage racks.



Walkie-Stacker – An electric powered device that the operator walks behind that is designed with a mast and is made for transporting palletized materials, with the option of stacking pallets up to four (4) high.



High Lift Truck / "Common Forklift" – The most commonly used powered industrial lift. Also referred to as a cantilever type forklift because it has a counter weight to offset the load it is designed to carry.



▼ Glossary & Terms:

Refer to the Preceding Forklift Components Drawing

Counter Weight

The rear section or area of the forklift which is usually made of solid steel, and/or combination of steel and the weight of the battery on an electric lift, that counter balances the load that is placed on the forks.

Data Plate

Manufacturer's equipment specification and information data, which includes load rating/lift capacity, lift heights, load center measurements vehicle weight and vehicle attachments. This plate is required to be affixed to all Industrial Lift Equipment by regulatory code. This is the vehicle operator's primary source of basic information about their vehicle for safe work and use planning.



Dumpster Bin

A fork-attachment used to transport a variety of materials. Always stand clear and keep hands away from all pinch points when releasing the lever to dump the bin.

 SAFETY & HEALTH MANUAL	Partnerships Built on Trust	16. Forklift & Industrial Safety	Page 4
		Revision Date: 1/8/2024	Updated

Fall Protection

An approved full body safety harness with lanyard is to be worn at all times and attached to a secure anchor point when drivers or personnel are using an Order Picker/Stock Picker Industrial Lift Truck or “Personnel Lifting Platform” fork attachment.

Fork Extensions

Using fork extensions does increase the forklift lift load capacity. Check with the manufacturer if fork extension can be used with their fork lift and a new load chart for the fork extensions.



Load Backrest Extension

A device (permanently affixed or removable) extending vertically from the fork carriage/load apron frame.

Load Apron

The part of the fork carriage permanently affixed and extending vertically from the fork carriage upon which the forks are “hung”/attached.

Mast

Part of the lifting mechanism that the hydraulic lift cylinders are attached which allows the load to be lifted up and down.

Overhead Guard

An overhead protection or shield which covers the machine operator in a manner that will minimize the possibility of injury from falling objects. Usually built into an ROPS.

Personnel Lifting Platform

A fork-attachment work platform designed for personnel to safely perform work in an elevated location. Fall protection is required during use of this attachment. Refer to the operating instructions for this fork attachment and “Fall Protection” in this section.

Powered Industrial Truck

A mobile power driven truck used for hauling, pushing, lifting or stacking materials.

Rider Truck

Any industrial lift truck that is designed to be controlled by a riding operator. The operator may be standing or sitting on the industrial lift truck during operation depending upon its design.

ROPS

An acronym for “Rollover Protective Structure” that includes protective frames, overhead guards and driver enclosures to isolate the driver from injury in a “safe zone” in the event of rollover or falling objects.



Partnerships
Built on Trust

SAFETY & HEALTH MANUAL

16. Forklift & Industrial Safety

Page

5

Revision Date: 1/8/2024

Updated

Seat Belt

The seat belt limits body movement and mechanically “connects” the operator to the equipment keeping the forklift operator inside the safety zone of the ROPS during a rollover.

Side Shifter

An equipment attachment that allows the forks and load apron carriage to be shifted side to side, allowing easier fork-load alignment.

Forklift Components Drawing

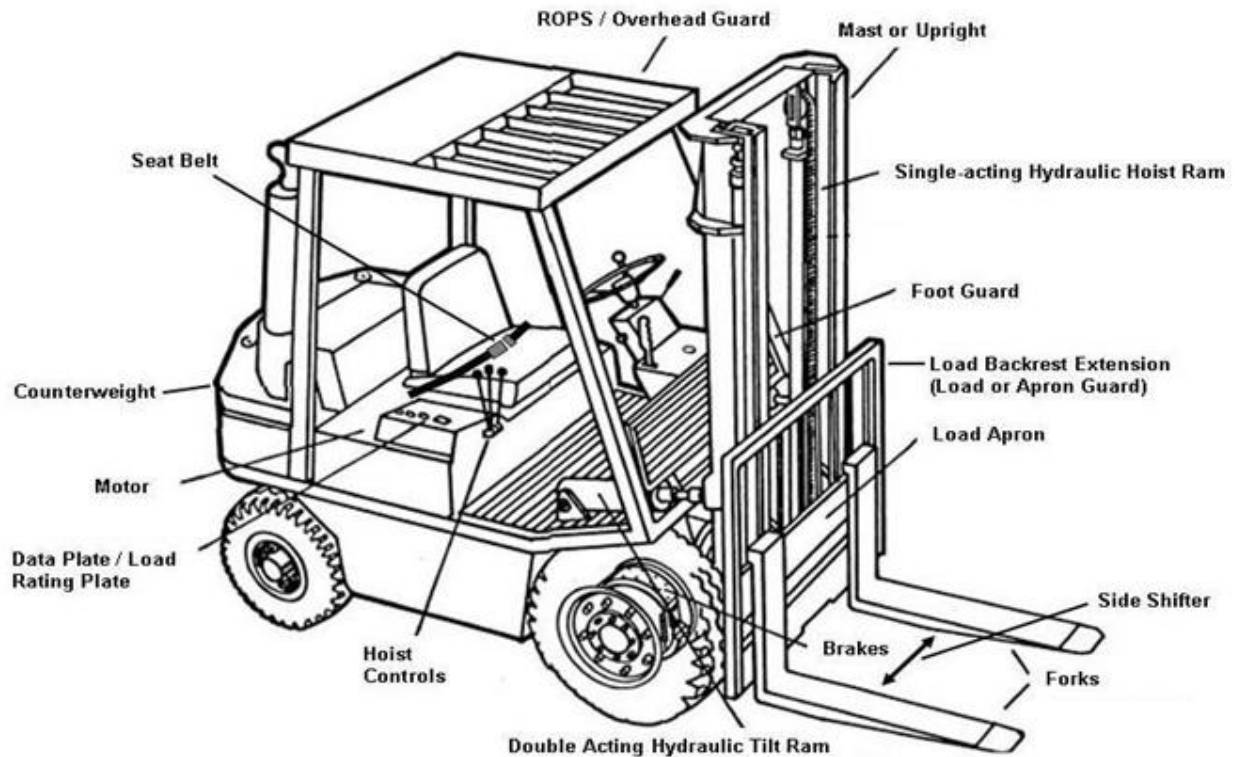

 SAFETY & HEALTH MANUAL	Partnerships Built on Trust	16. Forklift & Industrial Safety	Page 6
		Revision Date: 1/8/2024	Updated

▼ Vehicle Safety Inspection:

Prior to start of the workday, work-shift, or new material handling task, every industrial truck operator must:

- 1) Conduct, document and keep on file a completed vehicle safety inspection form.
- 2) If the lift truck is found to be unsafe during daily inspection, report this immediately to a supervisor or mechanic and do not use the lift truck until it has been repaired and made safe. Lift truck shall be locked/tagged out until repaired.
- 3) Complete any maintenance that the operator is required to perform.
- 4) Review work area for hazards, and remove/control them prior to operation.
- 5) Only use a truck designed to safely work in observed work area conditions.
- 6) Review operating instructions, limitations, warnings and precautions for the vehicle.
- 7) Remember the differences between the lift-truck drive-train/steering and an automobile.
- 8) Review controls and instrumentation. Where are they located, what do they do, and how do they work?
- 9) Review engine or motor operation, as well as steering and maneuvering.
- 10) Become familiar with visibility (including restrictions due to loading and truck components).
- 11) Review fork and attachment adaptation, operation and use limitations.
- 12) Review vehicle capacity and vehicle stability.
- 13) Check fuel or charge of batteries and refuel/recharge as needed.
- 14) Review operating instructions, warnings or precautions listed in the operator's manual, if available.
- 15) Alert all persons in the work area of intended work activities and hazards.

▼ Operating Instructions:

Prior to and during operation of an industrial lift truck, every operator must:

- 1) Securely fasten their seat belt if the lift truck has an ROPS.
- 2) Where possible, avoid operating the lift truck near ditches, embankments and holes.
- 3) Reduce speed when turning, crossing slopes and on rough, slick or muddy surfaces.
- 4) Stay off slopes too steep for safe operation.
- 5) Never permit others to ride the lift truck.
- 6) Operate the lift truck smoothly and safely, i.e., no jerky turns starts, stops, stunt driving or horseplay.
- 7) Hitch only to the drawbar and hitch points recommended by the lift truck manufacturer.
- 8) Set brakes securely and use park lock if available when the lift truck is stopped.
- 9) If a truck must be left unattended for a period of time, shut the vehicle off and remove the ignition keys.

 <p>Partnerships Built on Trust</p>	<p>16. Forklift & Industrial Safety</p>	<p>Page 7</p>
<p>SAFETY & HEALTH MANUAL</p>	<p>Revision Date: 1/8/2024</p>	<p>Updated</p>

- 10) Operator must verify trailer chocks, supports and dock plates prior to any loading or unloading operations.

 Partnerships Built on Trust	16. Forklift & Industrial Safety	Page 8
	SAFETY & HEALTH MANUAL	Revision Date: 1/8/2024

▼ **Securing the Load and Conducting the Lift/Carry:**

- 1) Always place the load against the backrest to help stabilize the load.
- 2) Always place the larger or heaviest part of the load closest to the backrest.
- 3) When carrying wide loads such as lumber or steel, adjust the forks as wide as possible.
- 4) Use ropes or straps to secure the load, but only attach to the backrest extension or apron carriage.
- 5) Use clamps or wood blocks to keep round objects such as pipes from rolling during transport.
- 6) Use shrink wrap or tape as needed to secure items stacked on pallets.
- 7) Always evaluate the situation before making an unusual lift.
- 8) If the load is too large to see around, always drive in reverse.
- 9) Never allow a person to walk or stand between the lift truck/load and another object.
- 10) Always carry the load as low as possible and watch for overhead obstructions.
- 11) Always honk the horn at intersections, blind spots, corners or where pedestrians are nearby.



Partnerships
Built on Trust

SAFETY & HEALTH MANUAL

**16. Forklift &
Industrial Safety**

Page

9

Revision Date: 1/8/2024

Updated

Lift Truck Work-Site Hazard Inspection Checklist Template

Lift Truck Site/Operation Hazard Assessment

Jobsite or Location(s): _____

Instructions: An Operator uses this form to conduct a Site Hazard Assessment for Industrial Lift Equipment, identify all hazards in the area of intended work, and to select appropriate equipment for the work-task.

Site Evaluation	YES	NO	N/A
Is the floor/work surface structurally strong enough to handle the			
Are surface conditions where the vehicle will be operated clean, dry and have good traction?			
Is there pedestrian traffic in areas where the vehicle will be operated?			
Are there narrow aisles and other restricted places where the vehicle will be			
Will the loads to be carried be stable and of uniform composition?			
Are there ramps and other sloped surfaces that could affect the vehicle's			
Will there be significant load manipulation, stacking and un-stacking of			
Are there "Classified Hazardous" locations where the vehicle will be operated?			
Is there an enclosed environment(s) or other areas where insufficient ventilation or poor vehicle maintenance could cause a build-up of carbon monoxide or diesel exhaust buildup for combustion motors, or hydrogen gas buildup at electric vehicle recharging stations?			
List below other potentially hazardous site-conditions that could affect safe			
1.			
2.			
Process / Use of Lift Truck	YES	NO	N/A
Should a Lift Truck(s) be used in the type of work being conducted?			
Does the Lift Truck(s) have the proper lift height and capacity for the job?			
Are the proper attachments being used in the type of work in this process?			
Are cables and/or chains being used to lift objects with the Lift Truck?			
Are there designated parking areas for Lift Truck(s)? (Clear of exits, fire extinguishers, hydrants, pedestrian-aisles, doorways, footpaths, or electrical			
Is the fueling and/or charging area well ventilated?			
Is there proper lighting in the areas the Lift Truck(s) is being used?			
In loading dock areas, are there proper dock plates available for use?			
Are Propane bottles being kept in a secure area, and are they tagged "Full" or "Empty"?			
List below other potentially hazardous process-conditions that could affect safe operation:			
1.			
2.			



Partnerships
Built on Trust

SAFETY & HEALTH MANUAL

**16. Forklift &
Industrial Safety**

Page

10

Revision Date: 1/8/2024

Updated

Safety Devices/Signs/Postings/Equipment Repair	YES	NO	N/A
Are there signs warning pedestrians that Lift Trucks are operating in the area?			
Are there proper warning signs at blind corners, exits, and high traffic areas?			
Are wheel chocks available if needed during loading or unloading of trucks or			
Are there proper warning signs in refueling or battery charging areas?			
Are all low overhead obstructions tagged, painted or marked for visibility to			
Are there walking lanes marked with yellow paint for pedestrians to use?			
Are there warning lights or buzzers to warn pedestrians on sidewalks of Lift Truck cross traffic?			
Is an eye wash station with a unobstructed path within 10 seconds walking-distance of the battery charging area?			
Are there a sufficient amount of fire extinguishers on site that have been inspected regularly?			
Is the CAL/OSHA poster (Operating Rules) posted and available to all employees who operate Lift Trucks?			
Are service repair orders for Lift Trucks and/or attachments(s) being kept for record keeping purposes?			
Are Daily Inspections being done, and are records being kept for program documentation?			
Are all other employees in the area aware that Lift Trucks are operating in the			
Are all safety devices on the Lift Truck in proper work condition (lights, horn, flashing lights, guards, seat belt, back-up alarm, etc.)?			
Are the Lift Trucks being kept in good working condition (maintenance, fuel, battery, oil, hoses, etc.)?			
List below other equipment device(s)/operation(s) that could improve safe			
1.			
2.			

Operator/Evaluator: _____

Date evaluated: ____ / ____ / ____

Pre-operation Inspection Checklist (Fuel Powered Forklifts)

HIGH-LIFT TRUCK/FORKLIFT TRUCK (Propane/Diesel/Gasoline)



Partnerships
Built on Trust

SAFETY & HEALTH MANUAL

**16. Forklift &
Industrial Safety**

Page

11

Revision Date: 1/8/2024

Updated

	Mon	Tues	Wed	Thurs	Fri	Sat	Sun
KEY OFF Procedures							
Overhead guard							
Hydraulic cylinders							
Mast assembly							
Lift chains and rollers							
Forks							
Tires (Front psi/Rear psi)							
Fuel System Fittings/Levels/Gages							
Examine the battery & fire extinguisher							
Check the engine/Trans oil level							
Check the hydraulic fluid level							
Check the engine coolant level							
KEY ON Procedures							
Check the gauges							
Hour meter							
Battery discharge indicator							
Test the standard equipment							
Steering							
Brakes							
Front, tail, and brake lights							
Horn							
Safety seat (including seatbelt)							
Operation of attachments							



Partnerships
Built on Trust

SAFETY & HEALTH MANUAL

**16. Forklift &
Industrial Safety**

**Page
12**

Revision Date: 1/8/2024

Updated

Starting Hour Meter Reading							
Pre-inspection date							
Operator's Printed Initial							

Instructions: Operator must check off each item as having been checked "OK" and safe to use during daily inspection prior to operation.

Operator/Evaluator: _____

Date evaluated: ____/____/____

 Partnerships Built on Trust SAFETY & HEALTH MANUAL	17. Hot Work Operations	Page 1
	Revision Date: 1/8/2024	Updated

Hot Work Operations

PURPOSE: The purpose of this policy is to provide Beeler Construction employees and management with the information necessary to safely and properly minimize the risk of injury and loss of property from fire or explosion as the result of hot work operations on Beeler Construction jobsites.

POLICY: Beeler Construction provides a safe and healthful workplace for all of its employees. All employees must become familiar with the following Hot Work Operations section of this safety manual. The following references have been used in preparation of this section, OSHA 29 CFR 1910 General Industry Safety & Health Standards, OSHA 20 CFR 1926.25, OSHA 29 CFR Subparts J & F and NFPA.

TRAINING: All Beeler Construction employees shall receive initial basic hot work operations training; refresher training will be provided periodically thereafter. Certain customers will require more stringent hot work rules and regulations. In these cases, additional training may be required specific to that customer's operations. All training as mentioned shall be recorded, name of employee with date of training and name of trainer recorded.

PROCEDURES:

▼ Hot Work Operations:

Hot Work Mitigation Program

Before performing any hot work operations in a completed structure occupied by non-construction employees (such as an occupied office building), a written hot work mitigation program must be provided for all hot work activities that could affect the ongoing operations at the structure before the start of hot work. The written program offers the owner an opportunity to provide input on proper protective methods and avoids unnecessary alarm system activation. It also allows the owner to notify user groups that could be affected so that they can plan for contingencies and responses in the event of an incident.

Hot Work Permit Program

Additionally, Beeler Construction project require written notification, through a hot work permit program to Beeler Construction and approval by Beeler Construction of all hot work operations that occur at any project. A hot work permit is required for all activities described above. The notification should describe the nature of the hot work activity, the areas and systems potentially affected; the duration of the work and what protective measures will be taken to ensure that fire risks are monitored and controlled. The hot work permit must be completed prior to any hot work procedures or activities taking place on Beeler Construction jobsites.

 Partnerships Built on Trust SAFETY & HEALTH MANUAL	17. Hot Work Operations	Page 2
	Revision Date: 1/8/2024	Updated

▼ **Risk of Fire:**

- 1) Any work described above may set fire to combustible materials in the vicinity of the work. When such operations are conducted, all explosive and combustible materials must be removed from the vicinity of the work or protected.
- 2) Each project should have established procedures for issuing hot work permits on a daily basis for each hot work activity that takes place. See the best practices described in standards, instructions and examples portion of this section for a specific project procedure. A member of Beeler supervision shall sign each permit before the start of hot work for the activity included in the hot work. It is critical that the fire safety supervisor inspect and monitor the activity for compliance with the permit.
- 3) A suitable fire extinguisher must be located within 35 feet of the hot work operation. The onsite project fire extinguishers cannot be used to comply with this requirement. Instead, the entity completing the hot work must provide its own fire extinguishers.
- 4) Additional precautions shall be taken as necessary to protect against all fire hazards identified in the pre-task planning process.
- 5) No welding and cutting shall be done on barrels and drums.
- 6) A fire watch must be maintained on all hot work areas until 30 minutes after all hot work is finished or for a longer period as deemed necessary by Beeler Construction. Required breaks should be considered in the timing of the hot work so that breaks do not impact the required timeframe to complete fire watches.
- 7) If hot work is to be completed on a wall, partition, ceiling or roof, precautions shall be taken to prevent ignition of combustibles on the other side by relocating combustibles. If it is impractical to relocate combustible, a fire watch must be posted on the opposite side from the work. Furthermore, for welding, cutting and grinding operations that pose a hazard of sparks and hot slag falling to lower levels, into wall cavities or passing through walls to another area, one or more of the following precautions must be implemented:
 - ✓ Follow good housekeeping practices
 - ✓ Water down the area (if allowed)
 - ✓ Use fire-resistant tarps or other suitable barriers to catch or deflect sparks and slag (combustible materials such as painting drop cloths should never be used to control hot sparks and slag during welding or cutting operations)
 - ✓ Post an additional fire watch or fire watches (in addition to the standard required fire watch) on all lower levels exposed to a possible spark, near areas of wall cavities exposed to sparks and in areas on opposite sides of walls from welding and cutting operations for the duration of the hot work and until 30 minutes after completion of the hot work.
- 8) Hot work must not be attempted on a partition, wall, ceiling or roof that has a combustible covering or insulation, or on walls or partitions of combustible sandwich-type panel construction until those combustible materials are removed or adequate protection is provided.



Partnerships
Built on Trust

SAFETY & HEALTH MANUAL

17. Hot Work Operations

Page
3

Revision Date: 1/8/2024

Updated

- 9) Combustible materials must be adequately protected while working on pipes of other metal, when the work is close enough to cause ignition by conduction.
- 10) Fully charged and operable fire extinguishers that are appropriate for the type of possible fire shall be placed and available within 35 feet of the hot work. These extinguishers are additional fire extinguishers to be supplied by the contractor performing the hot work. The fire extinguishers normally located in a building may not be considered to fulfill this requirement.
- 11) If hot work is performed in proximity to a sprinkler head, take appropriate precautions to avoid accidental operation of automatic fire detection or suppression systems.
- 12) Nearby personnel must be suitable protected against heat, sparks and slag.

▼ Work Closeout:

- 1) Maintain a fire watch for 30 minutes after all hot work is finished or for a longer period as deemed necessary by Beeler Construction. Required breaks should be considered in the timing of the hot work so that breaks do not impact the required timeframe to complete fire watches.
- 2) The fire safety supervisor must inspect the work site 30 minutes following completion of hot work and close out the permit with the time and date of the final check.
- 3) The completed hot work permit is to be retained in accordance with the document retention policy in the operations manual and the safety document retention guidelines.

▼ Ventilation:

- 1) Due to the harmful gases and fumes given off during some welding and cutting operations, adequate ventilation is critical. If local ventilation is not sufficient, forced ventilation must be used.
- 2) Inform the operating group safety department if there is the potential for any disturbance of heavy metal. The safety department will review and work with the project team on the proper ventilation and respiratory protection equipment required.

▼ Grinding Operations:

- 1) All grinding that produces sparks is considered hot work and must follow all hot work procedures, including the hot work permit requirements.

▼ Gas Welding and Cutting Operations:

- 1) All personnel must be trained before using gas welding or cutting equipment. Oxygen and fuel gas cylinders shall not be located directly under welding or cutting operations.
- 2) Hoses used must be:
 - ✓ Red for the acetylene hose
 - ✓ Green or black for the oxygen hose



Partnerships
Built on Trust

SAFETY & HEALTH MANUAL

17. Hot Work Operations

Page
4

Revision Date: 1/8/2024

Updated

- 3) When used, hoses and torches must be inspected daily for worn spots or defective connections. All defective equipment must be tagged and removed from service.
 - ✓ Proper procedures must be used when lighting or extinguishing the torch setup
 - ✓ Only an approved friction or spark-type lighter may be used
 - ✓ Acetylene may never be used at more than 15 pounds per square inch gauge pressure, or 30 pounds per square inch absolute pressure
- 4) Each torch must be equipped with a back flash arrestor at the torch hose end or in the torch valve assembly.
- 5) Secure all hot work equipment not in use within the previous 24-hour period (or longer) and conduct the following:
 - ✓ Close both acetylene and oxygen cylinder valves and open hoses momentarily, one at a time, to allow the line to discharge
 - ✓ Remove all gauges and place safety caps on cylinder(s)
 - ✓ Do not store or use cylinders in the horizontal position; in the horizontal position the safety valve does not allow the excess gas to escape but does allow the liquid to escape. This can result in an explosion.

▼ Welding:

- 1) Maintain welding equipment in good operation condition, any defective equipment must be removed from the jobsite and replaced.
- 2) Keep welding leads dry and free of oil.
- 3) Use only electrode holders that are fully insulated and in good condition.
- 4) Before starting welding operations, the operator must make certain that all electrical connections are securely made. The ground connection must be attached firmly to (and not merely laid loosely upon) the work, ground connections must never be made through pipelines carrying gases or flammable liquids.
- 5) Inspect welding leads for worn spots or exposed bare conductors. If such conditions are found, cover with rubber and friction tape.
- 6) Protect welding leads that must be laid on the floor. When possible, suspend welding lead at least 8 feet or higher.
- 7) Keep welding leads away from power supply or high-tension wires.
- 8) Welding leads must be placed so as not to be contacted by falling sparks.
- 9) When other employees are in the vicinity of electrical welding operations, the operations must be screened so that the employees cannot see the arc.

▼ Fire Protection:

- 1) All welding leads, hoses, cylinders and welding machines must be located away from sources of ignition, including falling slag and sparks.
- 2) All combustible materials must be removed or protected from the hot work area before starting work.

 Partnerships Built on Trust	17. Hot Work Operations	Page 5
	Revision Date: 1/8/2024	Updated
SAFETY & HEALTH MANUAL		

- 3) A fire watch must be established in exposed areas if the sparks fall below the floor(s) where the welder is working.



Partnerships
Built on Trust

SAFETY & HEALTH MANUAL

17. Hot Work Operations

Page
6

Revision Date: 1/8/2024

Updated

▼ Compressed Gas Cylinders:

- 1) If a cylinder is leaking and cannot be easily shut off:
 - ✓ Activate the emergency response plan
 - ✓ Evacuate the building and guard all entrances
 - ✓ Add ventilation to the area to try to clear out the escaping gas by opening doors and windows
 - ✓ Shut down all sources of ignition
 - ✓ Contact the gas supplier and follow the supplier's instructions regarding return by the supplier of the cylinder to the supplier's facility or other location as determined by the supplier
- 2) The gas supplier must be contacted if a cylinder:
 - ✓ Has been exposed to a fire
 - ✓ Is leaking
 - ✓ Might contain a mixture other than that marked on the cylinder
- 3) Each cylinder must bear the proper DOT label required for the compressed gas contained
- 4) Labels, decals, tags and stencil marks used for identification of cylinder contents must not be defaced.
- 5) Secure caps to empty cylinders and mark the cylinder with the work "EMPTY".
- 6) Do not place cylinders where they might become part of an electrical circuit.
- 7) Never attempt to repair or alter cylinders, valves or safety relief devices.
- 8) Never use cylinders for any purpose except for their intended use.

▼ Moving Cylinders:

- 1) Cylinder caps must be secured.
- 2) Never drop cylinders or permit cylinders to bump violently together or against any other surfaces, materials or equipment.
- 3) Never handle a cylinder with a lifting magnet.
- 4) Only lift cylinders in a proper lifting rig unless the cylinder is equipped with the proper lifting attachment.
- 5) Avoid dragging or sliding cylinders.
- 6) When transporting and unloading cylinders, always use a suitable hand truck, fork truck or similar device, with the cylinder firmly secured.

▼ Storing Cylinders:

- 1) Cylinders must be stored in accordance with all legal regulations, local requirements and appropriate standards of the Compressed Gas Association and the National Fire Protection Association.
- 2) Cylinder storage areas must be prominently posted to identify the gases to be stored.
- 3) All cylinders must be secured upright.

 Partnerships Built on Trust SAFETY & HEALTH MANUAL	17. Hot Work Operations	Page 7
	Revision Date: 1/8/2024	Updated

- 4) Charged and empty cylinders must be stored separately.
- 5) Cylinders may not be stored:
 - ✓ Where the temperature is above 125° Fahrenheit or
 - ✓ Near sources of heat
- 6) Do not store cylinders near highly flammable substances, such as gasoline, oil or waste.
- 7) Cylinders may not be stored in areas of continuous dampness, or near salt or other corrosive chemicals or fumes.
- 8) If ice or snow accumulates on a cylinder, thaw at room temperature.
- 9) Where gases of different types are stored at the same location, cylinders must be grouped by types of gas. Note: oxygen must be separated from fuel gases by a minimum of 20 feet or a 30 minute rated wall at least 5 feet high.

▼ **Withdrawing Cylinder Contents:**

- 1) Compressed gases may only be handled by properly trained employees.
- 2) Check all cylinders to ensure that they are marked with the identity of the gas; if they are not, do not accept the cylinders.
- 3) All cylinders must be secured during use.
- 4) Never force a connection that does not fit.
- 5) Open cylinder valves slowly. Note: on cylinders that are hard to open or frozen due to corrosion, contact the supplier for instructions.
- 6) Never use compressed gas to dust off clothing.
- 7) When compressed gas cylinders are connected to a manifold, the manifold and all related equipment must be of proper design.

RESPONSIBILITIES

Project Manager

Ensure that all subcontract documents reflect the requirements of this section. Make sure that the subcontractor fulfills the project safety requirements according to the subcontract. Spot check hot work permits.

Project Superintendent

Ensure that the Beeler Construction hot work program is being properly implemented. Ensure that all project personnel have been trained on Beeler Construction's hot work policy. Assume the responsibilities of fire safety supervisor as outlined in the following paragraph.

 SAFETY & HEALTH MANUAL	Partnerships Built on Trust	17. Hot Work Operations	Page 8
		Revision Date: 1/8/2024	Updated

Subcontractor Foreman and/or Superintendent

- 1) Review all hot work operations performed by his/her crew.
- 2) Ensure that all individuals involved in the hot work operations are familiar with Beeler's hot work requirements.
- 3) Ensure that all individuals involved in the hot work operations are trained in the safe operation of equipment and the hot work procedures listed on the hot work permit. These individuals must have an awareness of the risks involved, understand the emergency procedures and be trained on the use of fire extinguishing devices in the event of a fire.
- 4) Ensure that only approved apparatus such as torches, manifolds, regulators and pressure reducing valves are used.
- 5) Inspect the area for flammable materials, hazardous processes or other potential fire hazards present or likely to be present in the work location.
- 6) Ensure that combustibles are protected from ignition by the following means:
 - ✓ Verify that fire protection and extinguishing equipment are properly located and readily available; do not consider site fire extinguishers for the additional fire extinguishers required for hot work activities
 - ✓ Ensure that local exhaust ventilation is provided to prevent accumulation of smoke and fumes
 - ✓ Ensure that a fire watch is posted at the site when needed

Fire Safety Supervisor

The fire safety supervisor must review and issue hot work permits and is responsible for the safe operation of hot work activity. Fire safety supervisor must complete the following:

- 1) Establish permissible areas for hot work.
- 2) Ensure that all individuals involved in the hot work operations are familiar with Beeler's hot work requirements.
- 3) Ensure that all individuals involved in the hot work operations are trained in the safe operation of equipment and the safe use of the hot work procedures listed on the hot work permit. Individuals involved in hot work operations must have an awareness of the risks involved, understand the emergency procedures and be trained on the use of fire extinguishing devices in the event of a fire.
- 4) Determine if flammable materials, hazardous processes or other potential fire hazards are present or are likely to be present in the work location.
- 5) Ensure that combustibles are protected from ignition by the following means:
 - ✓ Move the work to a location free from combustibles. If the work cannot be moved, ensure that the combustibles are removed to a safe distance or have the combustibles properly shielded against ignition
 - ✓ Ensure that ignition of flammables or combustibles do not occur during hot work operations
 - ✓ If the above 2 conditions cannot be met, the work must not be performed

 <p>Partnerships Built on Trust</p> <p>SAFETY & HEALTH MANUAL</p>	<p>17. Hot Work Operations</p>	<p>Page 9</p>
	<p>Revision Date: 1/8/2024</p>	<p>Updated</p>

- 6) Determine that fire protection and extinguishing equipment are properly located and readily available within 35 feet of the hot work. Additional fire extinguishers must be supplied by the contractor performing the hot work. The fire extinguishers normally located in a building may not be considered to fulfill this requirement.
- 7) Ensure that sufficient local exhaust ventilation is provided to prevent accumulation of smoke and fumes.
- 8) The fire safety supervisor shall make a final inspection 30 minutes after the completion of hot work operations to detect and extinguish possible smoldering fires.

Person Doing Hot Work

The person completing hot work shall handle the equipment safely and perform work so as not to endanger lives and property. Specific requirements are as follows:

- 1) Hot work shall not be conducted without specific written authorization from the fire safety supervisor via completion of the hot work permit.
- 2) The operator must cease hot work operations if unsafe conditions develop.
- 3) The person doing hot work must notify the fire safety supervisor for reassessment of the situation in the event of suspected unsafe conditions or concerns expressed by affected persons.

Fire Watch

The fire watch is an individual posted in the work area(s) where hot work is being monitored. The function of the fire watch is to observe the hot work and monitor conditions to ensure that a fire or explosion does not occur as a result of the work performed. The fire watch is authorized to stop any unsafe operation or activity. Specific duties and responsibilities are as follows:

- 1) Watch for fires, smoldering material or other signs of combustion.
- 2) Be aware of the inherent hazards of the work site and of the hot work.
- 3) Ensure that safe conditions are maintained during hot work operations and stop the hot work operations if unsafe conditions develop.
- 4) Have the appropriate fire-extinguishing equipment readily available and be trained on the proper procedures of extinguishing fires.
- 5) Extinguish fires when the fires are within the capacity of the equipment available. If the fire is beyond the capacity of the equipment, activate the project emergency response procedures for fires.

Maintain a fire watch for 30 minutes after all hot work is finished or for a longer period as deemed necessary by Beeler. Required breaks should be considered in the timing of the hot work so that breaks do not impact the required timeframe to complete fire watches.

More than one fire watch shall be required if combustible materials that could be ignited by the hot work operation cannot be directly observed by a single fire watch (e.g., in

 Partnerships Built on Trust	17. Hot Work Operations	Page 10
	Revision Date: 1/8/2024	Updated
SAFETY & HEALTH MANUAL		

adjacent rooms where the hot work is done on a common wall or on floors below where the hot work sparks could fall).

 Partnerships Built on Trust	17. Hot Work Operations	Page 11
	Revision Date: 1/8/2024	Updated
SAFETY & HEALTH MANUAL		

▼ **Standards, Instructions and Examples:**

Beeler Construction has established best practices for hot work permits. The following establishes methods for ensuring that hot work is completed safely for Beeler and its subcontractors.

- 1) Prior to hot work authorization, the work areas are inspected by Beeler and the subcontractor in accordance with the rules of the permit.
- 2) A color-coded thumb tack is placed on the site map at the location where the work will take place.
- 3) The copy of the permit is retained in the Beeler office near the site map. This provides the Beeler project management team the ability to track and monitor where all hot work is taking place. The permit is also used for the daily safety audit to ensure the appropriate approach can be checked during the day.
- 4) At the end of the day, the person performing the hot work is required to complete the fire watch, return the closed-out hot work permit, match it with the Beeler copy and pull the thumb tack from the site map. This ensures that at the end of the day all hot work is formally closed out.
- 5) The Beeler project management team shall review the site map and determine that all hot work is complete and closed out. All permits must be closed and the site map clear at the end of each day.



Beeler Construction Hot Work Permit

Permit No.	This permit must be completed for all cutting, welding and other hot work performed on jobsites.
	The permit must be displayed at the work site and returned to the authorized site representative on completion of work for sign off and filing.

Application for hot work

Contractor Performing Work: _____

Contact Name: _____ **Tel:** () _____

Location of Work: _____

Description of Work:

Equipment to be used:

Permit begins	Permit expires
Date: / / Time: am/pm	Date: / / Time: am/pm

Emergency information

If a fire occurs, call _____ **Tel:** () _____

Nearest fire alarm:

Authorization by site representative

The above work is authorised to proceed subject to the following action being taken prior to work starting and procedures being maintained for the duration of the work. Each item is to be checked by the Authorised Site Representative prior to work starting for each period (delete and initial if and where Not Applicable).

Authorised by: _____ **Signed:** _____ **Date:** / /

1	Fire Sprinklers and/or Thermal Detectors must be confirmed as operational (where installed).	<input type="checkbox"/>	6	Combustible materials located within 10 m must be removed or protected with non-combustible curtains, metal guards or flameproof covers (not ordinary tarpaulins). In a retail/office environment if 10m clearance is not practical then the largest distance possible (minimum of 3m) is acceptable.	<input type="checkbox"/>
2	Smoke Detectors must be isolated in the work area and Impairment Procedures followed.	<input type="checkbox"/>	7	All floor & wall openings within 10m must be covered to prevent transmission of sparks.	<input type="checkbox"/>
3	Fire equipment to be provided as follows: • Fire Hose Reel • Fire Extinguisher Mandatory fire watcher present	<input type="checkbox"/> <input type="checkbox"/> <input type="checkbox"/>	8	The hot work area and any adjoining areas must be patrolled from the start of work until 30 minutes after the work is completed (including break periods).	<input type="checkbox"/>
4	Barricades, warning signs & spark/flash screens must be provided.	<input type="checkbox"/>	9	Special Conditions. (Please detail)	
5	Work area, trenches, pits, etc. must be clear of flammable liquids, gases, or vapours.	<input type="checkbox"/>			

Work Completed and Area Safe

The work area has been inspected by the Authorized Site Representative 30 minutes after completion of work:

Signed: _____ **Date:** / / **Time:** _____ **am/pm**

This permit is only valid for 24 hours. Ensure contractor returns this form.

 SAFETY & HEALTH MANUAL	Partnerships Built on Trust	18. Safety Training	Page 1
		Revision Date: 1/8/2024	Updated

Safety Training

Ongoing & Specialized Safety Training

PURPOSE: To provide guidelines for completion of necessary safety training based on job requirements and to ensure that all training required by health & safety regulations is provided to all Beeler Construction employees.

POLICY: Beeler Construction will maintain a safe and healthful workplace and will ensure that its employees receive the training necessary to safely perform their work. Beeler Construction will also ensure that all training required by law is provided to its employees.

PROCEDURES:

▼ Responsibilities:

Responsibilities for safety training exist at all levels of the organization. Employees are responsible for attending and applying the information presented at safety training sessions.

Foreman are responsible for providing employees with information and training regarding the hazards associated with the work and the methods and safety devices employees can use to safely complete their assigned work.

Management may use the services of outside organizations in completing the safety training necessary, especially certain specialized safety training identified in this procedure.

▼ Initial Training of New Hires:

All new Beeler Construction employees will be provided with initial training that includes: general safety rules and rules of conduct, chemical hazard communication, responsibilities regarding accident reporting, use of personal protective equipment and safety rules or procedures specific to their particular job.

Because new employees may be hired at different times, Beeler Construction may schedule new employee safety orientation training when a group of new employees is available. Until the formal training is conducted, each employee shall be instructed by his foreman or superintendent in the hazards associated with his work, the personal protective equipment that is to be used and the specific safety procedures associated with the employee's assigned duties.

All new Beeler Construction employees are required to read in full the Beeler Construction Safety Manual and sign and date the Employee Acknowledgement Safety

 Partnerships Built on Trust	18. Safety Training	Page 2
	Revision Date: 1/8/2024	Updated
SAFETY & HEALTH MANUAL		

Training Form and return it to the office. Preferably this should be done prior to the new employee starting work.

 Partnerships Built on Trust	18. Safety Training	Page 3
	Revision Date: 1/8/2024	Updated

▼ **Frequency of Training:**

All Beeler Construction employees shall attend quarterly safety meetings and participate in tool box safety training sessions at least twice every month. There is no minimum time limit for these meetings and the subject of the safety training session may consist of general discussion of jobsite safety issues or a review of the Beeler Construction's current safety performance or recent accidents. Many of the safety meetings will be facilitated through the use of tool box safety talks that each foreman uses with his group of employees.

▼ **General Safety Training:**

Safety Training Subject Matter:

The topics selected for safety training should be related to hazards and issues common to the group of Beeler Construction employees being trained. Recent accidents, near misses, safety problems or observed unsafe behavior are topics that can be discussed during this ongoing safety training. Beeler Construction may utilize the services of outside trainers to plan and conduct quarterly safety meetings. Weekly toolbox talks are issued at the beginning of each work week electronically to all team members and reviewed on site. Possible topics for quarterly meetings and weekly tool box safety training include:

- ✓ Back injury prevention
- ✓ Inspection and safe use of tools
- ✓ Electrical safety
- ✓ Fall protection
- ✓ Preventing slips, trips and falls
- ✓ Eye protection
- ✓ Hand protection
- ✓ Hearing protection
- ✓ Injury reporting requirements
- ✓ Chemical hazard communication
- ✓ Fire safety
- ✓ Use of portable fire extinguishers
- ✓ Motor vehicle safety
- ✓ Emergency procedures
- ✓ Avoiding heat related illnesses
- ✓ Avoiding cold related emergencies
- ✓ Heavy equipment safety
- ✓ Housekeeping

 SAFETY & HEALTH MANUAL	Partnerships Built on Trust	18. Safety Training	Page 4
		Revision Date: 1/8/2024	Updated

▼ **Specialized Safety Training:**

Beeler Construction may provide specialized safety training to its employees. The need for this training depends on the type of work being performed or the nature of the materials that may be encountered during work. Such training is typically conducted on a job per job basis and typically involves the services of an outside trainer. Most of the training is conducted in a classroom setting and lasts longer than one hour.

Specialized safety training is either required by OSHA regulations or provided based upon the hazard of the work or exposure involved. Beeler Construction requires all employees be trained on the any job specific specialize safety programs prior to starting work on that job, examples possible specialized safety programs are listed below.

- ✓ Chemical hazard communication
- ✓ Fall protection training
- ✓ Scaffolding safety
- ✓ Confined space entry
- ✓ Excavation safety and protective systems
- ✓ Hearing conservation program
- ✓ Lockout and tagout program
- ✓ Personal protective equipment

Documentation of Training:

Documentation of all safety training, including the names and signatures of employees that attend and subject matter presented will be maintained for all safety meetings and safety training sessions. The form at the end of this procedure or other forms provided by the instructor shall be used to document this training.

 Partnerships Built on Trust	19. Safety Inspections	Page 1
	SAFETY & HEALTH MANUAL	Revision Date: 1/8/2024

Safety Inspections

Work Area & Jobsite Safety Inspections

PURPOSE: To provide guidelines for routine safety inspections of all Beeler Construction jobsites and equipment. Inspections conducted by project management, superintendents and foreman are designed to identify unsafe condition and work practices that can lead to accidents and injury.

POLICY: Beeler Construction provides a safe and healthful workplace for all employees and subcontractors. The safety inspection procedures that follow will be used to identify and correct unsafe conditions and work practices identified during routine work area and jobsite safety inspections at all active Beeler Construction projects.

PROCEDURES:

▼ Responsibilities:

Foremen:

Each superintendent and foreman is responsible for conducting work area safety inspections each work day of the areas and work activities they are responsible for. These inspections are not required to be documented, but each foreman is required to monitor the work activities of their employees, subcontractors they are responsible for, the condition of tools and equipment used in his operation and safety issues present at each jobsite. A daily site safety audit checklist is included in the forms section of this manual, this can be used in conjunction with and recording safety inspection notes in the Foreman's Daily Log book.

If an unsafe condition, equipment, or vehicle is noted by the inspector, he should correct the problem or notify the supervisor if he lacks the authority or ability to correct the problem. The problem should also be noted in the Daily Log book. If the superintendent or foreman notes unsafe behavior or a violation of a safety rule by one of his employees, he should immediately notify the employee and take disciplinary action if necessary. If the inspector notes the unsafe behavior or a violation of a safety rule by a subcontractor's employee, he should contact the subcontractor's site representative for correction. The Beeler Construction project manager should also be contacted in the event further action is required of the subcontractor. A superintendent or foreman must NEVER ignore unsafe behavior or a violation of a safety rule. Ignoring violations of safety rules condones other unsafe behavior.

 SAFETY & HEALTH MANUAL	Partnerships Built on Trust	19. Safety Inspections	Page 2
		Revision Date: 1/8/2024	Updated

Management:

Management is responsible for ensuring that superintendents and foremen conduct routine undocumented safety inspections and that problems noted during such inspections are addressed. Management is also responsible for ensuring that periodic, documented inspections are conducted. These inspections may be conducted by outside sources or internally. All such formal inspections should be documented and contain a brief description of the problem or unsafe work activity observed. Beeler Construction management is responsible for responding to all items identified during the inspection. Estimated dates to complete the corrective action should be noted and kept in the file where safety inspection reports are maintained.

▼ Frequency of Inspections:

Formal comprehensive inspections of facilities, equipment and work sites should be conducted at least monthly. A comprehensive monthly site safety inspection checklist is included in the forms section of this manual. This form is to be completed once a month and kept on file. Any corrective action taken, or planned to be taken, shall be noted on the inspection report and placed in the file where inspection reports are maintained.

▼ Corrective Action:

Many of the items on the checklist can be immediately corrected by the superintendent or foreman at the time it is noted during the inspection. If the item cannot be corrected immediately, a note should be made on the checklist indicating the date that the deficiency will be corrected. Any corrective action that is not within the authority of the foreman to correct should be noted on the inspection checklist and discussed with the project manager as soon as possible.

Most accidents and injuries are the result of the unsafe act or behavior committed by an employee. Therefore, the focus of all inspections should be on the work activities of Beeler Construction employees and employees of subcontractors. If an employee is observed working in an unsafe manner, he should be instructed in the correct way to perform his work. If the employee is observed violating a safety rule that he was instructed in or knowledgeable about, he should be disciplined according to the company's disciplinary action policy for safety violations. If a subcontractor's employee is observed violating a site safety rule, the subcontractor's site representative should be contacted or the Beeler Construction project manager should be contacted to inform the subcontractor's project representative.

If the inspection reveals that more than one employee is not employing safe work practices, the employees may need to receive formal training in the work methods or procedures that they are not familiar with.

 Partnerships Built on Trust SAFETY & HEALTH MANUAL	20. OSHA Inspection	Page 1
	Revision Date: 1/8/2024	Updated

OSHA Inspection Procedures

Purpose

It is *Beeler Construction* policy to fully cooperate with inspections by regulatory agencies such as the Occupational Safety and Health Administration (OSHA).

Scope

This section applies to all *Beeler Construction* projects.

Policies

The following procedures Must be followed when an OSHA or another regulatory agency representative arrives at a *Beeler Construction* project

Notification

Notify the Safety Department as soon as the compliance officer arrives at the project site. The Safety Representative will immediately head to the project. Notify *Beeler Construction* management that OSHA is onsite.

Correct Any Unsafe Conditions

Look around before OSHA is walking the worksite. Fix any unsafe condition that was created by *Beeler Construction*. If *Beeler Construction* employees are exposed to other contractor's hazard, remove workers from the hazardous area. While OSHA is onsite do not perform any high hazard work, such as working off ladders, scaffolding or where fall protection is needed.

Inspection Procedures

OSHA Inspections

It is *BEELER CONSTRUCTION's* policy to fully cooperate with inspections by regulatory agencies such as the Occupational Safety and Health Administration (OSHA).

The following procedures must be followed when an OSHA or another agency representative arrives at our project:

Inspectors must be escorted.

Instruct all *BEELER CONSTRUCTION* personnel to escort the inspector to the Manager. This should be done without entering the job site if at all possible. Ask to see their identification "badge" and a business card. If there are any questions about their identification contact the OSHA's Area Office for further identification.

Forms must be completed.

 <p>Partnerships Built on Trust</p> <p>SAFETY & HEALTH MANUAL</p>	<p>20. OSHA Inspection</p>	<p>Page 2</p>
	<p>Revision Date: 1/8/2024</p>	<p>Updated</p>

Inspectors must be accompanied.

Manager will accompany the inspector at all times.

Be courteous.

Extend every courtesy to make the inspector's brief visit as pleasant as possible.

Correct any unsafe conditions immediately.

Before the inspector leaves the site, request clarification of any hazards observed and the abatement that the inspector would like to see.

The inspector may talk to employees.

If the inspector wishes to talk to employees during the walk around, he is allowed to do so by law. This talk should be limited to about five (5) minutes.

The employee has the right to refuse to talk to the inspector. Cooperation is expected from all staff on the site.

All employees, *BEELER CONSTRUCTION* and subcontractors, should cooperate with the inspection.

Explain that BEELER CONSTRUCTION, subcontractors and OSHA are conducting this inspection together, and the welfare of ALL employees is the purpose for the inspection.

Inspections may be videotaped.

Some inspectors may use a video camera. Be careful what is said when the recorder is being used.

Pictures may be taken.

If the inspector takes a picture, *Beeler Construction* should take two or three to get a complete view of the hazard.

Identify the company responsible for violations.

If violations are alleged by the OSHA representative, identify the company responsible for or contributing to the conditions leading to the violation during the closing conference.

Post citations conspicuously.

Citations must be posted for three days or until the citation is abated, whichever comes first, on the job site in a place where employees pass frequently.

Inspection Follow-up

1. Review all proposed penalties and citations.
2. Set-up and attend the informal conference with OSHA.

 <p>Partnerships Built on Trust</p> <p>SAFETY & HEALTH MANUAL</p>	<p>20. OSHA Inspection</p>	<p>Page 3</p>
	<p>Revision Date: 1/8/2024</p>	<p>Updated</p>

OSHA INSPECTION REPORT

Inspection Dates and Times: _____

1. Pre-Inspection

a. Person and title contact by OSHA:

b. Did inspector show his credentials? Yes / No

If no, comment:

c. Names of OSHA inspectors and their area office:

d. What was the reason for the inspection?

1. Employee complaint? Yes / No

(If yes, attach copy. OSHA is required by law to provide a copy.)

2. Scheduled inspection? Yes / No

3. Other (comment):

 <p>Partnerships Built on Trust</p> <p>SAFETY & HEALTH MANUAL</p>	<p>20. OSHA Inspection</p>	<p>Page 4</p>
	<p>Revision Date: 1/8/2024</p>	<p>Updated</p>

2. Opening Conference

- a. Names of contractors, their representatives and titles: (or attach list)

3. Inspection Tour

- a. Who from *BEELER CONSTRUCTION* accompanied the OSHA inspector?

1. Who else joined the OSHA inspection group?

- b. Did the inspector take any photographs? Yes / No

1. Did *BEELER CONSTRUCTION* take any photographs? Yes / No

- c. Were safety hazards and unsafe acts observed? Yes / No

1. If yes, what were they and who had responsibility?

- d. Was immediate corrective action taken? Yes / No

1. If no, comment:

- e. Special comments regarding inspection:

 <p>Partnerships Built on Trust</p> <p>SAFETY & HEALTH MANUAL</p>	<p>20. OSHA Inspection</p>	<p>Page 5</p>
	<p>Revision Date: 1/8/2024</p>	<p>Updated</p>

4. Closing Conference

a. Did OSHA hold closing conference w/ *BEELER CONSTRUCTION*? Yes / No

1. With other contractors? Yes / No

b. Names of contractors, their representatives and titles: (or attach list)

c. What alleged OSHA violations were discussed and with whom? (or attach list)

NOTE:

At the Closing Conference, it is very important to establish which citations rightfully belong to *BEELER CONSTRUCTION* versus other companies. When citations are incorrectly assigned, *BEELER CONSTRUCTION* is forced to spend unnecessary time and money contesting them.

This OSHA Inspection Report is to be started at the beginning of and completed immediately after an OSHA inspection.

 Partnerships Built on Trust	21. Fleet Safety Program	Page 1
	SAFETY & HEALTH MANUAL	Revision Date: 1/8/2024

Fleet Safety Program

POLICY: Beeler Construction is committed to instituting and maintaining a Fleet Safety Program. The goal of the Fleet Safety Program is to take the proper steps to prevent loss of life, injury, or property damage to all employees and members of the general public. Beeler Construction recognizes that the responsibilities for safety and loss prevention must be shared by everyone.

As with all work related safety, Beeler Construction's emphasis is protecting the health and welfare of our employees.

Responsibilities

1) Management

- a) Monitor driving records of all employees who operate a company vehicle.
- b) Verify that adequate insurance limits are maintained by drivers who use their personal vehicle for entity business.
- c) Review all accidents whether they be "no fault" or "at fault" and take corrective action to prevent a recurrence.
- d) Establish disciplinary actions for drivers who show a repeated disregard for good driving practices.
- e) Insist that all assigned vehicles are maintained adequately for safe operation and kept clean.
- f) Periodic inspect vehicles for safety discrepancies, malfunctions, signs of abuse, unreported damage and cleanliness. Have repairs made as soon as possible.

2) Employees / Operators

- a) No employee shall operate a company vehicle or his or her personal vehicle for company purposes without a valid driver's license. Employees will notify Management as soon as possible if their operator's license has been suspended, revoked or expired.
- b) No employee shall ever operate a company vehicle while under the influence of alcohol or drugs. No employee shall operate his or her own personal vehicle for company business related work under the influence of alcohol or drugs.
- c) No employee shall operate a company vehicle when his or her ability to do so safely has been impaired by illness, fatigue, injury or prescription medications. No employee shall operate his or her own personal vehicle for company business related work when his or her ability to do so safely has been impaired by illness, fatigue, injury or prescription medications.
- d) The driver is responsible for checking the safety and general condition of the vehicle, including gas, oil, and other fluid levels, lights, and brakes.

 SAFETY & HEALTH MANUAL	Partnerships Built on Trust	21. Fleet Safety Program	Page 2
		Revision Date: 1/8/2024	Updated

- e) No employee will use a vehicle for any purpose for which it was not designed, operate it beyond its designed limits, operate it in areas or locations for which it was not designed, or cause damage through neglect, misuse, improper driving techniques, or improper handling.
- f) While transporting employees in Beeler Construction vehicles the amount of passengers will be limited to the amount of available seat belts. Seat belts must be worn by all occupants at all times, no exceptions. No employee will be authorized to ride or work from the bed or rear of a vehicle while it is in motion.
- g) Employees will adhere to all traffic laws and regulations when operating Beeler Construction vehicles. If employees receive a traffic citation, they must report it to Management as soon as possible
- h) Beeler Construction vehicles should be used for company business only. Employees must receive permission form Management prior to using a company vehicle for personal use. Persons found using company vehicles for their personal errands may be subject to disciplinary action.
- i) Operation and occupancy of company vehicles by unauthorized persons is not allowed. Employees shall not permit unauthorized employees or non-employees to ride in company vehicles, except when it is a requirement for a specific project or job duty, or if authorized by management, or in an emergency situation.
- j) Employees are responsible for the security of company vehicles assigned to them, all doors must be locked and the engine must be shut off when the vehicle is unattended. **If a vehicle is left with a parking attendant only the ignition key is to be left with the attendant.**
- k) For employees using their personal vehicles for company business, the employee's own insurance policy will be the primary coverage and, therefore, Beeler Construction will not be responsible for any claims that arise out of any motor vehicle accident that the employee is involved while operating their personal vehicle. The mileage reimbursement the employee receives is intended to fully cover all costs of the operation of the employee's personal vehicle including but not limited to fuel, maintenance, repairs, insurance, etc.
- l) Employees when transporting equipment, packages or other materials in the driver/passenger compartment of company vehicles will exercise caution so as to avoid these objects from becoming flying projectiles in the event of an accident. Such items as briefcases, laptop computers, tools, etc. if possible should to be transported in the trunk of passenger vehicles. Pickups, whether standard cab or extended, should have secured storage capabilities in the bed of the vehicle such as tool storage or camper shells if they are used with any regularity in the transport of items that could injure the driver or passenger(s) in the event of an accident. Vans used in the regular transport of such items should have screen type barriers between such cargo and the driver/passenger compartment. It is always important to keep the driver/passenger as free as possible of objects that could distract their attention or could cause from unexpected movement.

 Partnerships Built on Trust	21. Fleet Safety Program	Page 3
	Revision Date: 1/8/2024	Updated

SAFETY & HEALTH MANUAL

Defensive Driving

Employees operating company vehicle and their own personal vehicles for company business use should follow the Defensive Driving Rules listed below.

- 1) Drivers of passenger vehicles are required to maintain a safe driving distance between their vehicle and the vehicle ahead. During slippery road conditions, the distance between vehicles should be doubled.
- 2) Drivers of heavy trucks are required to keep a *minimum* of at least 4 seconds interval between the truck and the vehicle ahead. This interval shall be doubled during adverse weather conditions.
- 3) Drivers must yield the right of way at all traffic control signals and signs requiring them to do so. Drivers should also be prepared to yield for safety's sake at any time. Pedestrians and bicycles in the roadway always have the right of way.
- 4) Avoid driving in other driver's blind spots; attempt to maintain eye contact with the other driver, either directly or through mirrors.
- 5) Drivers must honor posted speed limits. In adverse driving conditions, reduce speed to a safe operating speed that is consistent with the conditions of the road, weather, lighting, and volume of traffic. Tires can hydroplane on wet pavement at speeds as low as 40 MPH.
- 6) Turn signals must be used to show where you are heading; while going into traffic and before every turn or lane change.
- 7) When passing or changing lanes, view the entire vehicle in your rear view mirror before pulling back into that lane.
- 8) Be alert of other vehicles, pedestrians, and bicyclists when approaching intersections. Never speed through an intersection on a caution light. Approach a stale green light with your foot poised over the brake to reduce your reaction time should it be necessary to stop. When the traffic light turns green, look both ways for oncoming traffic before proceeding.
- 9) When waiting to make left turns, keep your wheels facing straight ahead. If rear-ended, you will not be pushed into the lane of oncoming traffic.
- 10) When stopping behind another vehicle, leave enough space so you can see the rear wheels of the car in front. This allows room to go around the vehicle if necessary, and may prevent you from being pushed into the car in front of you if you are rear-ended.
- 11) Avoid backing where possible, but when necessary, keep the distance traveled to a minimum and be particularly careful.
- 12) Check behind your vehicle before backing. Operators of heavy trucks should walk around their vehicle before backing and/or have someone guide you.
- 13) Do not back around a corner or into an area of no visibility.

 SAFETY & HEALTH MANUAL	Partnerships Built on Trust	21. Fleet Safety Program	Page 4
		Revision Date: 1/8/2024	Updated

Eligibility

1) Driver Eligibility

Beeler Construction believes knowing the ability, experience and attitude of drivers is a key factor in the selection process. An important area in this process is to establish qualification standards for new employees and existing employees that have driving duties. To enforce these standards, Beeler Construction has implemented the following driver qualification procedures.

- All drivers must be a minimum of (18) years of age and have a valid Operator's License
- Beeler Construction will obtain a legible copy of all employees Operator's Licenses. A review of the license will be conducted to be certain it is valid, has not expired, and is the appropriate for the class of vehicles in which driving is required.
- Beeler Construction will request a Motor Vehicle Record (MVR) for all employees in which driving company vehicle or operating their own vehicle for company business will be required. An MVR will be requested from every state the applicant has lived in during the past (three) years. The Safety Director will review all MVR information to determine if driver applicant meets the qualification standards regarding driving records. A formal review of the driver's MVR will be conducted on a/an annual basis (or more frequently where warranted) to ensure that existing drivers are meeting the established qualification standards. MVR's are personal and confidential and should only be discussed with the driver or other persons authorized to know. Management will receive results of the MVR check; any needed corrective action will be applied in a timely manner.
- To ensure that potential new and existing drivers meet Beeler Construction's motor vehicle qualification standards set forth in the Fleet Safety Program, a system will be established with regard to MVR checks/violations. Violations will be broken into two categories, Type "A" and Type "B" as follows.

Type "A" Violations:

- Driving While Intoxicated
- Driving While Under The Influence of Drugs
- Negligent Homicide Arising Out Of The Use Of A Motor Vehicle
- Operating During A Period Of Suspension Or Revocation
- Using A Motor Vehicle For The Commission Of A Felony
- Aggravated Assault With A Motor Vehicle
- Operating A Motor Vehicle Without The Owner's Permission – Theft

 Partnerships Built on Trust SAFETY & HEALTH MANUAL	21. Fleet Safety Program	Page 5
	Revision Date: 1/8/2024	Updated

- Permitting An Unlicensed Person To Drive
- Reckless Driving
- Speed Contest (Racing)
- Hit And Run (Bodily Injury Or Property Damage)
- Fleeing police
- Excessive Speeding (15 mph over posted limit)
- A second preventable accident

Type “B” Violations:

- Speeding
 - Failing to stop for a school bus
 - Failing to stop at a railroad crossing
 - Failure to obey traffic signs/control devices
 - Failure to yield to right of way
 - Speed to fast for conditions
 - Reckless driving
 - A first preventable accident
 - Seat belt violations
 - Failure to use turn signals
 - Improper stopping/parking
- Type “A” violations will result in termination of company vehicle driving privileges for a time period to be determined by management. Certain Type “A” violations may lead to termination of employment.
 - Any driver with (4) or more Type “B” violations over a period of (3) years will be restricted from driving company vehicles.
 - An employee who receives any Type “A” or and Type “B” moving violation must notify management of the incident within (10) days after receipt of the ticket or conviction.
 - Any employee who has his or her Operator’s License revoked or suspended must notify management within (3) days of the incident.
 - Please note all reported incidents and MVR record checks will be kept private.

Accidents

1) Accidents

Review and documentation of all accidents, whether they be “at fault” or “no fault”, is of the utmost importance. All accidents (regardless of their severity) involving company vehicles must be reported to management immediately. All accidents involving

 Partnerships Built on Trust SAFETY & HEALTH MANUAL	21. Fleet Safety Program	Page 6
	Revision Date: 1/8/2024	Updated

employees personal vehicles while being used for company purposes must be reported immediately as well.

 SAFETY & HEALTH MANUAL	Partnerships Built on Trust	21. Fleet Safety Program	Page 7
		Revision Date: 1/8/2024	Updated

What to do in case of an accident:

Step 1: Stop, stay calm

Step 2: Turn on your emergency flashers as an immediate warning signal. Then do a quick evaluation of accident victims, if any. **IF THERE ARE INJURIES CALL 911 IMMEDIATELY FOR MEDICAL AND POLICE ASSISTANCE** and attend to the victims.

Step 3: If possible set out emergency warning devices on the roadway.

Step 4: Either contact local law enforcement personnel and management yourself or arrange to have someone do it for you. Be courteous and cooperative when providing information to authorities. Never admit guilt or liability at the scene of an accident. Never leave the scene of an accident.

Step 5: Write down names, license numbers and other information regarding the accident and those people involved in it, do the same for any witnesses. Draw a simple diagram of the accident scene. The more detail you can provide, the better it will be for insurance and/or legal purposes later. If you have a camera for use at the accident scene, document the situation with photographs from various angles. (Note: a disposable camera is included in the emergency kits in the Cube and Flat Bed trucks).

Step 6: After the vehicle has been secured, warning devices put in place, assistance rendered to injured person(s) (if any), and law enforcement personnel contacted, you (the driver) should communicate the accident to Management.

Step 7: Complete a Vehicle Accident Report Form at the scene of the accident, these forms should be found in the glove compartments in both the Cube and Flat Bed trucks, samples of these are found at the end of this section.

2) Vehicle Accident Review

Management will review all vehicle accidents to determine the true cause and whether it was “at fault” or “no fault”. They will convene as soon as possible after the accident to determine cause, they will review the drivers past records, they will document the findings and if deemed necessary meet with the driver to discuss disciplinary action.

Vehicle Loading

It is important to ensure that vehicles selected for a specific function are adequate in design and capability for the intended purpose. It is the responsibility of each driver to select the appropriate vehicle to be used in performing tasks. For hauling materials the following weight loading limits apply to the vehicles.

 Partnerships Built on Trust SAFETY & HEALTH MANUAL	21. Fleet Safety Program	Page 8
	Revision Date: 1/8/2024	Updated

Typical Superintendent's Van (Ford E-150)

Maximum pay load (combined weight of cargo and passengers) – 3,000 lbs.

Flat Bed/Stake Truck (Ford F-550)

Maximum pay load (combined weight of cargo and passengers) – 7,300 lbs.

Cube Truck (Ford F 550)

Maximum pay load (combined weight of cargo and passengers) – 5,500 lbs.

- If you have any questions on the weight of the materials the Project Manager in charge would be able to answer any job specific details.
- If you are transporting materials or equipment in your personal vehicle and question its capabilities, the maximum pay load should be listed on the driver's door column.
- For towing trailers please contact management for towing limits.
- Depending on materials being transported common sense should apply, if the cargo is valuable and needs to be protected from the elements the cube truck should be used, for building materials, tools and equipment the flat bed is usually preferred. When transporting materials in the flat bed, if weather is a question, tarps and or plastic should be used to protect materials.

Vehicle Maintenance

It is the policy of Beeler Construction to keep all vehicles well maintained and in safe and efficient operating condition at all times. A good preventive maintenance program lowers repair frequency, lowers overall maintenance cost and also provides a safer working environment

1) Vehicle Inspections

Pre-trip inspections will be required for the cube and flat bead trucks; drivers must complete a Vehicle Inspection Report (VIR) prior using the vehicles regardless on trip distance. On longer trips (multiple days), the drivers must complete the (VIR) on a daily basis. Inspection reports will be located in a binder in each truck. The following are VIR's are to be used.

 Partnerships Built on Trust SAFETY & HEALTH MANUAL	21. Fleet Safety Program	Page 9
	Revision Date: 1/8/2024	Updated

CUBE TRUCK (Ford F 550) (1FDUF5GTGLDAO7654)
HT 12'0" EW 12,500 GVW 18,000 Max Load 5,500lbs USDOT 594574

PRE-TRIP VEHICLE MAINTENANCE CHECKLIST

Before you drive this vehicle the following pre-trip inspection check list must be completed.

Engine Warm?

Check fuel level, **DIESEL** only (tank fill on driver's side) , **DEF LEVEL**

Engine Gauges (Oil, Temperature, Check Engine, Volts-Battery, Etc)

Cooling System/Antifreeze Level

Brake Operation

Windshield and Wiper Blades

Head Lights/Driving Lights

Parking Brake Operation

Mirrors: Side, Rear-view

Brake Lights/Turn Signals

Tail Lights/Reverse Lights/Audible reverse signal/ Horn

Tire Wear/Inflation

Heater and AC functioning

Is Load Secure?

The following items should be kept in the vehicles at all times: First Aid Kit, Blanket, Spare Fuses, Shovel, Engine Fluids, Flashlight with Extra Batteries, Road Flares, Reflective Vest, Tool Kit, Fire Extinguisher, Jumper Cables, Duct or Electrical Tape, Jack/Lug nut Wrench,

Additionally the driver should consider if they are taking a long trip to bring along water and possibly non perishable food

Employee Name _____

Date and Time _____

 Partnerships Built on Trust SAFETY & HEALTH MANUAL	21. Fleet Safety Program	Page 10
	Revision Date: 1/8/2024	Updated

FLAT BED/STAKE TRUCK (Ford F550)

PRE-TRIP VEHICLE MAINTENANCE CHECKLIST

Before you drive this vehicle the following pre-trip inspection check list must be completed.

- Engine Gauges (Oil, Temperature, Check Engine, Volts-Battery, etc.)
- Gas (Drivers side)
- Cooling System/Antifreeze Level
- Brake Operation
- Windshield and Wiper Blades
- Head Lights/Driving Lights
- Parking Brake Operation
- Mirrors: Side, Rear-view
- Brake Lights/Turn Signals
- Tail Lights/Reverse Lights
- Tire Wear/Inflation
- Horn
- Heater and AC functioning
- Is Load Secure?

The following items should be kept in the vehicles at all times: First Aid Kit, Blanket, Spare Fuses, Shovel, Engine Fluids, Flashlight with Extra Batteries, Road Flares, Reflective Vest, Tool Kit, Fire Extinguisher, Jumper Cables, Duct or Electrical Tape, Jack/Lug nut Wrench.

Additionally the driver should consider if they are taking a long trip to bring along water and possibly non-perishable food.

Employee Name _____

Date and Time _____

 Partnerships Built on Trust	21. Fleet Safety Program	Page 11
	SAFETY & HEALTH MANUAL	Revision Date: 1/8/2024

2) Vehicle Maintenance File

A complete record on each vehicle in the fleet will be kept. It will include basic vehicle information and information indicating the nature and due date of any inspections and maintenance operations to be performed on the vehicle, and a record of any inspections, repairs and maintenance performed on the vehicle in question, including dates performed and specifics on the nature of the operations. Employees with company vehicles should keep all paperwork of oil changes and any other services or repairs and give a copy to management. The typical routine maintenance schedule should be followed if whenever possible. Depending on the vehicle these recommendations may vary.

Routine Service

- Every 3000 Miles -Lube-Oil-Filer
- Every 5000 Miles -Rotate tires and balance
- Every 12,000 miles -Air Filter - PCV Valve -Brake Service -Front-end alignment - Engine tune-up -Transmission Service
- Every 20,000 Miles -Shock absorbers - Automatic Transmission drain /refill
- Every 36,000 Miles -Differential drain/refill - Wheel bearing package

Every 3 months inspect the following: (make required repairs)

- All fan, A/C, power belts
- Radiator, heater, A/C hoses
- A/C, heater system
- Power steering
- Windshield wiper blades and arms
- Doors and windows

 Partnerships Built on Trust SAFETY & HEALTH MANUAL	21. Fleet Safety Program	Page 12
	Revision Date: 1/8/2024	Updated

Every 6 months inspect the following: (make required repairs)

- Alternator/generator
- Battery
- Exhaust system, muffler, converter, tail pipe
- Emission control system
- Ignition system
- Door locks and window mechanisms
- Fuel tank and suspension system

Annually inspect and/or conduct the following: (make required repairs)

- Comprehensive engine tune-up and analysis
- Comprehensive steering/brake system evaluation
- Comprehensive body/paint check
- Comprehensive evaluation of emission control system
- Drain, flush, and clean cooling system-refill
- Electrical wiring
- Suspension system
- Mechanical linkages
- Interior condition

3) Vehicle Breakdown

In case of breakdown the driver should safely stop the vehicle, parking on the appropriate side of the street and or in the emergency lane on a highway. Put on the reflective vest found in the emergency kit. The load should be checked and secured. Warning devices should be placed on the road if possible. Diagnose the problem as best you can and call it into the office, management will make the necessary arrangements for towing/repairs.



Partnerships
Built on Trust

SAFETY & HEALTH MANUAL

22. Forms

Revision Date: 1/8/2024

Updated

Employee Acknowledgement of Safety Rules

I have read and fully understand the Safety Rules and Employee Responsibilities established by Beeler Construction, Inc. I will perform my work in accordance with the rules provided to me. I am aware that a violation of Safety Rules or Policy may result in disciplinary action, including possible termination.

I also acknowledge that I have received training in Beeler Construction's general safety rules and rules of conduct, personal protective equipment, and my responsibilities regarding the reporting of occupational injuries occurring on Beeler Construction time.

I pledge that I will obey the Safety Rules prescribed for my work and that I will actively participate in Beeler Construction, Inc.'s safety programs. I also understand that my safety and the safety of my co-workers is of primary importance and that any questions I have regarding safety should be directed to my supervisor.

Beeler Construction, Inc. Employee Signature

Printed Name

Date

Employee Notification of Safety Violation

Date: _____

Foreman: _____

Employee Name: _____

Description of Violation:

- _____ **First Violation**
- _____ **Second Violation**
- _____ **Third Violation**

Beeler Construction Foreman/Management Signature

Beeler Construction Employee Signature

Date

Subcontractor Confirmation of Non-Compliance with Safety and Health Standards

Job Number: _____ **Job Address:** _____

Date: _____

To: _____

On _____, you were verbally advised of the following violation(s) of the State Safety Regulations and/or Federal Occupations Safety and Health Act of 1970 and/or _____.

1. _____
2. _____
3. _____
4. _____
5. _____

Note: If the first violation is corrected in a timely manner, the violation will be disregarded.

Please indicate below the corrective action you intend to take on each of the above-noted violation(s) and the dates by which each item will be corrected. Return this form to the undersigned by: _____
Date

Beeler Construction, Inc.

Corrective Action to be Taken

- | | |
|----------|-------------|
| 1. _____ | Date: _____ |
| 2. _____ | Date: _____ |
| 3. _____ | Date: _____ |
| 4. _____ | Date: _____ |
| 5. _____ | Date: _____ |

Name: _____ Title: _____ Date: _____

Beeler Employee Injury Form

JOB:		EXACT LOCATION:	
DATE OF OCCURRENCE:	TIME:	DATE REPORTED:	SUPERVISOR:
PERSONAL INJURY		PROPERTY DAMAGE	
INJURER'S NAME:		PROPERTY DAMAGED:	
PHONE #:	INJURED BODY PART:	ESTIMATED COSTS:	ACTUAL COSTS:
NATURE OF INJURY:		NATURE OF DAMAGE:	
OBJECT/EQUIPMENT/SUBSTANCE/INFLECTING INJURY:		OBJECT/EQUIPMENT/SUBSTANCE/INFLECTING DAMAGE:	
DESCRIBE CLEARLY HOW THE ACCIDENT OCCURRED: (ATTACH DIAGRAM OF BUILDING OR AREA IF POSSIBLE)			
WHAT ACTS, FAILURES TO ACT AND/OR CONDITIONS CONTRIBUTED TO THIS ACCIDENT: NONE			
WERE MECHANICAL GUARDS (SHIELDS, BARRIERS) OR OTHER SAFEGUARDS (PPE) PROVIDED? NA			
WHAT ACTION HAS OR WILL BE TAKEN TO PREVENT RECURRENCE? Ensuring lift with legs.			
NAME OF WITNESS:		WERE PHOTOS TAKEN?	DIAGRAMS ATTACHED?
INVESTIGATED BY:	DATE:	REVIEWED BY:	DATE:

Non-Employee/Subcontractor Injury Form

JOB:		EXACT LOCATION:	
DATE OF OCCURRENCE:	TIME: AM PM	DATE REPORTED:	SUPERVISOR:
PERSONAL INJURY		PROPERTY DAMAGE	
INJURER'S NAME:		PROPERTY DAMAGED:	
PHONE #:	INJURED BODY PART:	ESTIMATED COSTS:	ACTUAL COSTS:
NATURE OF INJURY:		NATURE OF DAMAGE:	
OBJECT/EQUIPMENT/SUBSTANCE/INFLICTING INJURY:		OBJECT/EQUIPMENT/SUBSTANCE/INFLICTING DAMAGE:	
DESCRIBE CLEARLY HOW THE ACCIDENT OCCURRED: (ATTACH DIAGRAM OF BUILDING OR AREA IF POSSIBLE)			
WHAT ACTS, FAILURES TO ACT AND/OR CONDITIONS CONTRIBUTED TO THIS ACCIDENT:			
WERE MECHANICAL GUARDS (SHIELDS, BARRIERS) OR OTHER SAFEGUARDS (PPE) PROVIDED?			
WHAT ACTION HAS OR WILL BE TAKEN TO PREVENT RECURRENCE?			
NAME OF WITNESS:		WERE PHOTOS TAKEN?	DIAGRAMS ATTACHED?
INVESTIGATED BY:	DATE:	REVIEWED BY:	DATE:

Supervisor's Catastrophe Investigation/Employee Injury Form

JOB:		EXACT LOCATION:	
DATE OF OCCURRENCE:	TIME: AM PM	DATE REPORTED:	SUPERVISOR:
PERSONAL INJURY		PROPERTY DAMAGE	
INJURER'S NAME:		PROPERTY DAMAGED:	
PHONE #:	INJURED BODY PART:	ESTIMATED COSTS:	ACTUAL COSTS:
NATURE OF INJURY:		NATURE OF DAMAGE:	
OBJECT/EQUIPMENT/SUBSTANCE/INFLICTING INJURY:		OBJECT/EQUIPMENT/SUBSTANCE/INFLICTING DAMAGE:	
DESCRIBE CLEARLY HOW THE ACCIDENT OCCURRED: (ATTACH DIAGRAM OF BUILDING OR AREA IF POSSIBLE)			
WHAT ACTS, FAILURES TO ACT AND/OR CONDITIONS CONTRIBUTED TO THIS ACCIDENT:			
WERE MECHANICAL GUARDS (SHIELDS, BARRIERS) OR OTHER SAFEGUARDS (PPE) PROVIDED?			
WHAT ACTION HAS OR WILL BE TAKEN TO PREVENT RECURRENCE?			
NAME OF WITNESS:		WERE PHOTOS TAKEN?	DIAGRAMS ATTACHED?
INVESTIGATED BY:	DATE:	REVIEWED BY:	DATE:

Daily Site Safety Inspection
(To Be Performed By Superintendent)

Date: _____ Project Name: _____

Project Number: _____ Superintendent: _____

Mark an "X" before each item that has been checked. Write an explanation in the Hazard Description below of items that needed attention.

- ____ 1. Review work to be done with subcontractors superintendents and make them aware of any special safety concerns, get a head count of all workers on site that day
- ____ 2. Check overall site housekeeping
- ____ 3. Check to make sure lighting is adequate
- ____ 4. Check to see if hardhats and other P.P.E.'s are being worn where required
- ____ 5. Check to see if fire extinguishers are in place
- ____ 6. Check to see if combustible liquids are stored in an acceptable manner
 - a. Are acceptable safety cans being use?
 - b. Are combustible liquids stored at the appropriate distances?
 - c. Make sure combustible liquids are not stored near "hot" areas
- ____ 7. Check to see if gas and oxygen cylinders are stored in an acceptable manner
 - a. Are the gas and oxygen cylinders stored separately?
 - b. Are gas cylinders stored upright with caps in place and secured to prevent tipping?
- ____ 8. Check fall protection requirements
 - a. Are guard rails installed where required?
 - b. Are workers using fall protection where required?
 - c. Are roof lines and warning lines in place?
- ____ 9. Visually inspect and check scaffolding
- ____ 10. Check traffic and fire egress pathways, are they clear?
- ____ 11. Check and inspect excavations
- ____ 12. Check for electrical hazards, have they been identified/posted, are all cords colored correctly
- ____ 13. If crane is on site, have overhead power lines been discussed/identified?
- ____ 14. Check temporary stairs and ladders, are they in compliance?
- ____ 15. Are toilet facilities clean?

Item No.	Hazard Description	Action Taken	Date Complete

Monthly Jobsite Safety Inspection
(To Be Performed Superintendent and Safety Director if Present)

Jobsite Information & Documentation		<input type="checkbox"/> Yes <input type="checkbox"/> No <input type="checkbox"/> N/A
1	OSHA and other necessary postings in place	<input type="checkbox"/> <input type="checkbox"/> <input type="checkbox"/>
2	Company Safety Manual on site	<input type="checkbox"/> <input type="checkbox"/> <input type="checkbox"/>
3	SDS files available in trailer on site	<input type="checkbox"/> <input type="checkbox"/> <input type="checkbox"/>

Housekeeping, Sanitation, First Aid		<input type="checkbox"/> Yes <input type="checkbox"/> No <input type="checkbox"/> N/A
4	Toilet facilities adequate and clean	<input type="checkbox"/> <input type="checkbox"/> <input type="checkbox"/>
5	Jobsite housekeeping acceptable	<input type="checkbox"/> <input type="checkbox"/> <input type="checkbox"/>
6	First aid supplies available	<input type="checkbox"/> <input type="checkbox"/> <input type="checkbox"/>
7	Emergency phone numbers posted	<input type="checkbox"/> <input type="checkbox"/> <input type="checkbox"/>

Environmental Health		<input type="checkbox"/> Yes <input type="checkbox"/> No <input type="checkbox"/> N/A
8	Subcontractors have written program on site	<input type="checkbox"/> <input type="checkbox"/> <input type="checkbox"/>
9	SDS available for all hazardous chemicals on site	<input type="checkbox"/> <input type="checkbox"/> <input type="checkbox"/>
10	Concrete grinding, sawing, breaking performed wet	<input type="checkbox"/> <input type="checkbox"/> <input type="checkbox"/>
11	Respirators worn when exposed to concrete/mortar dust	<input type="checkbox"/> <input type="checkbox"/> <input type="checkbox"/>
12	Respirators worn & used properly	<input type="checkbox"/> <input type="checkbox"/> <input type="checkbox"/>
13	Lighting adequate in all work areas	<input type="checkbox"/> <input type="checkbox"/> <input type="checkbox"/>

Fire Prevention		<input type="checkbox"/> Yes <input type="checkbox"/> No <input type="checkbox"/> N/A
14	Safety cans used for storage of flammable liquids	<input type="checkbox"/> <input type="checkbox"/> <input type="checkbox"/>
15	Adequate number of fire extinguishers available	<input type="checkbox"/> <input type="checkbox"/> <input type="checkbox"/>
16	Fire extinguishers sealed and inspected (check date tags)	<input type="checkbox"/> <input type="checkbox"/> <input type="checkbox"/>
17	Fire extinguishers near torch and welding work	<input type="checkbox"/> <input type="checkbox"/> <input type="checkbox"/>
18	Gas cylinders stored upright with caps in place	<input type="checkbox"/> <input type="checkbox"/> <input type="checkbox"/>
19	Oxygen and fuel gas cylinders stored separately	<input type="checkbox"/> <input type="checkbox"/> <input type="checkbox"/>
20	Gas cylinders secured to prevent them from tipping	<input type="checkbox"/> <input type="checkbox"/> <input type="checkbox"/>
21	Combustibles removed from torch or welding areas	<input type="checkbox"/> <input type="checkbox"/> <input type="checkbox"/>
22	Fire extinguisher located near "hot" kettles	<input type="checkbox"/> <input type="checkbox"/> <input type="checkbox"/>
23	Flammable liquid storage compliance	<input type="checkbox"/> <input type="checkbox"/> <input type="checkbox"/>

Personal Protective Equipment		<input type="checkbox"/> Yes <input type="checkbox"/> No <input type="checkbox"/> N/A
24	All person on site wearing hard hats	<input type="checkbox"/> <input type="checkbox"/> <input type="checkbox"/>
25	Eye protection used with saws, grinding, chipping, etc.	<input type="checkbox"/> <input type="checkbox"/> <input type="checkbox"/>
26	Shoes/boots appropriate and in good condition	<input type="checkbox"/> <input type="checkbox"/> <input type="checkbox"/>
27	Welding/burring goggles used	<input type="checkbox"/> <input type="checkbox"/> <input type="checkbox"/>

Tools		<input type="checkbox"/> Yes	<input type="checkbox"/> No	<input type="checkbox"/> N/A
28	Power tools, saws, etc. equipped with proper guards	<input type="checkbox"/>	<input type="checkbox"/>	<input type="checkbox"/>
29	Blades of power saws properly installed and undamaged	<input type="checkbox"/>	<input type="checkbox"/>	<input type="checkbox"/>
30	Cases on double insulated tools intact and not cracked	<input type="checkbox"/>	<input type="checkbox"/>	<input type="checkbox"/>
31	Handles on tools in good condition and not cracked or taped	<input type="checkbox"/>	<input type="checkbox"/>	<input type="checkbox"/>
32	Hand tools in good condition	<input type="checkbox"/>	<input type="checkbox"/>	<input type="checkbox"/>
33	Tools in need of repair are removed from jobsite	<input type="checkbox"/>	<input type="checkbox"/>	<input type="checkbox"/>

Electrical Safety		<input type="checkbox"/> Yes	<input type="checkbox"/> No	<input type="checkbox"/> N/A
34	All electrical tools/equipment grounded or double insulated	<input type="checkbox"/>	<input type="checkbox"/>	<input type="checkbox"/>
35	All overhead electrical hazards identified, posted, protected	<input type="checkbox"/>	<input type="checkbox"/>	<input type="checkbox"/>
36	Ground fault protection (GFCI) available/used	<input type="checkbox"/>	<input type="checkbox"/>	<input type="checkbox"/>
37	Extension and equipment cords in good condition and have proper color coding	<input type="checkbox"/>	<input type="checkbox"/>	<input type="checkbox"/>
38	Temporary lighting hung from the baskets	<input type="checkbox"/>	<input type="checkbox"/>	<input type="checkbox"/>

Scaffolding		<input type="checkbox"/> Yes	<input type="checkbox"/> No	<input type="checkbox"/> N/A
39	Scaffolding secure, level and plumb	<input type="checkbox"/>	<input type="checkbox"/>	<input type="checkbox"/>
40	Are all legs properly braced	<input type="checkbox"/>	<input type="checkbox"/>	<input type="checkbox"/>
41	Are all working platforms fully planked	<input type="checkbox"/>	<input type="checkbox"/>	<input type="checkbox"/>
42	Planks overlap 6-8inches on end frames or have end cleats	<input type="checkbox"/>	<input type="checkbox"/>	<input type="checkbox"/>
43	Planks overlap each other at least 12 inches	<input type="checkbox"/>	<input type="checkbox"/>	<input type="checkbox"/>
44	Guard rails on all scaffold platforms over 10 feet	<input type="checkbox"/>	<input type="checkbox"/>	<input type="checkbox"/>
45	Toe boards on all working platforms of scaffolds	<input type="checkbox"/>	<input type="checkbox"/>	<input type="checkbox"/>
46	Is the height/width ratio acceptable or is the scaffold properly secured to the structures	<input type="checkbox"/>	<input type="checkbox"/>	<input type="checkbox"/>
47	Cross bracing properly installed on scaffold (rolling scaffold needs to be fully braced)	<input type="checkbox"/>	<input type="checkbox"/>	<input type="checkbox"/>
48	Casters on rolling towers locked when set in place	<input type="checkbox"/>	<input type="checkbox"/>	<input type="checkbox"/>
49	Fall protection worn in boom trucks and lifts	<input type="checkbox"/>	<input type="checkbox"/>	<input type="checkbox"/>

Fall Protection		<input type="checkbox"/> Yes	<input type="checkbox"/> No	<input type="checkbox"/> N/A
50	Guard rails installed on all open sides/floors with 6 feet fall exposure	<input type="checkbox"/>	<input type="checkbox"/>	<input type="checkbox"/>
51	Guard rails sound and free of obvious defects & strong enough to withstand 200#	<input type="checkbox"/>	<input type="checkbox"/>	<input type="checkbox"/>
52	Holes in floors/roofs protected by adequate covers or guard rails	<input type="checkbox"/>	<input type="checkbox"/>	<input type="checkbox"/>
53	Workers using fall protection equipment when exposed 6 feet fall	<input type="checkbox"/>	<input type="checkbox"/>	<input type="checkbox"/>
54	Anchor point sufficient for fall protection equipment	<input type="checkbox"/>	<input type="checkbox"/>	<input type="checkbox"/>
55	Fall protection equipment free of excessive wear, cuts, defects	<input type="checkbox"/>	<input type="checkbox"/>	<input type="checkbox"/>
56	Window openings less than 39 inches protected by guard rails	<input type="checkbox"/>	<input type="checkbox"/>	<input type="checkbox"/>
57	Warning line systems used for flat roofing work	<input type="checkbox"/>	<input type="checkbox"/>	<input type="checkbox"/>
58	Guard rail systems used at "hot" pipe and hoist areas on roof	<input type="checkbox"/>	<input type="checkbox"/>	<input type="checkbox"/>
59	Skylights protected by guard rails or covers on roof	<input type="checkbox"/>	<input type="checkbox"/>	<input type="checkbox"/>
60	Safety monitors used for workers outside of warning line system	<input type="checkbox"/>	<input type="checkbox"/>	<input type="checkbox"/>
61	Workers laying brick overhand in a controlled access zone	<input type="checkbox"/>	<input type="checkbox"/>	<input type="checkbox"/>
62	Work areas below barricaded to protect from fall materials	<input type="checkbox"/>	<input type="checkbox"/>	<input type="checkbox"/>

Cranes		<input type="checkbox"/> Yes <input type="checkbox"/> No <input type="checkbox"/> N/A		
63	Cranes equipped with load charts or indicators	<input type="checkbox"/>	<input type="checkbox"/>	<input type="checkbox"/>
64	Swing radius of crane barricaded or protected	<input type="checkbox"/>	<input type="checkbox"/>	<input type="checkbox"/>
65	Operators manual available in cab or crane	<input type="checkbox"/>	<input type="checkbox"/>	<input type="checkbox"/>
66	Outriggers of crane fully extended	<input type="checkbox"/>	<input type="checkbox"/>	<input type="checkbox"/>
67	Rigging properly secured and free of defects	<input type="checkbox"/>	<input type="checkbox"/>	<input type="checkbox"/>
68	Safety latch in place on crane hook	<input type="checkbox"/>	<input type="checkbox"/>	<input type="checkbox"/>
69	Crane operated no closer than 10 feet from overhead power lines less than 50 kV, check OSHA guidelines if more than 50 kV	<input type="checkbox"/>	<input type="checkbox"/>	<input type="checkbox"/>

Excavations		<input type="checkbox"/> Yes <input type="checkbox"/> No <input type="checkbox"/> N/A		
70	Excavations greater than 5 feet deep use protective system	<input type="checkbox"/>	<input type="checkbox"/>	<input type="checkbox"/>
71	Protective system/sloping adequate for soil type	<input type="checkbox"/>	<input type="checkbox"/>	<input type="checkbox"/>
72	Spoil piles kept at least 2 feet from edge of excavation	<input type="checkbox"/>	<input type="checkbox"/>	<input type="checkbox"/>
73	Water removed from excavation prior to entry by employees	<input type="checkbox"/>	<input type="checkbox"/>	<input type="checkbox"/>
74	Subcontractor has "competent person" on site at all times	<input type="checkbox"/>	<input type="checkbox"/>	<input type="checkbox"/>
75	Shoring and trench shields used properly	<input type="checkbox"/>	<input type="checkbox"/>	<input type="checkbox"/>

Stairways and Ladders		<input type="checkbox"/> Yes <input type="checkbox"/> No <input type="checkbox"/> N/A		
76	Ladders extend at least 3 feet above landing areas	<input type="checkbox"/>	<input type="checkbox"/>	<input type="checkbox"/>
77	Ladders secured to the structure to prevent tipping	<input type="checkbox"/>	<input type="checkbox"/>	<input type="checkbox"/>
78	Ladders in good condition and free of defects	<input type="checkbox"/>	<input type="checkbox"/>	<input type="checkbox"/>
79	Non-metal ladders used for electrical hazards/work	<input type="checkbox"/>	<input type="checkbox"/>	<input type="checkbox"/>
80	Stairs/temporary stairs provided with handrail/stair rail	<input type="checkbox"/>	<input type="checkbox"/>	<input type="checkbox"/>
81	Metal pan stairs filled flush with wood/material until complete	<input type="checkbox"/>	<input type="checkbox"/>	<input type="checkbox"/>
82	Stairs free of construction debris, electrical cords, etc.	<input type="checkbox"/>	<input type="checkbox"/>	<input type="checkbox"/>
83	Platforms/landings allow 20 inches more than door swing	<input type="checkbox"/>	<input type="checkbox"/>	<input type="checkbox"/>

For any NO answers, describe corrections taken.

Date: _____

Jobsite Location: _____

Inspector's Name: _____

Signature: _____

Superintendent: _____

Signature: _____

OSHA INSPECTION REPORT

Inspection Date/Time: _____

Pre-Inspection	YES	NO	
Person and title contact by OSHA:			
Did inspector show his credentials? If no, why?	<input type="checkbox"/>	<input type="checkbox"/>	
Names of OSHA inspectors and their office area:			
Reason for the inspection:			
Employee complaint? (If yes, attach copy. OSHA is required by law to provide a copy).	<input type="checkbox"/>	<input type="checkbox"/>	
Scheduled inspection?	<input type="checkbox"/>	<input type="checkbox"/>	
Other (comment)	<input type="checkbox"/>	<input type="checkbox"/>	
Opening Conference			
Names of contractors, their representatives and titles (or attach list):			
Inspection Tour		YES	NO
Who from Beeler Construction accompanied the OSHA inspector?			
Who else joined the OSHA inspection group?			
Did the inspector take any photographs?	<input type="checkbox"/>	<input type="checkbox"/>	<input type="checkbox"/>
Did Beeler Construction take any photographs?	<input type="checkbox"/>	<input type="checkbox"/>	<input type="checkbox"/>
Were safety hazards and unsafe acts observed? If yes, what were they and who had responsibility?	<input type="checkbox"/>	<input type="checkbox"/>	<input type="checkbox"/>
Was immediate corrective action taken? If no, why?	<input type="checkbox"/>	<input type="checkbox"/>	<input type="checkbox"/>
Special comments regarding inspection:			
Closing Conference		YES	NO
Did OSHA hold closing conference with Beeler Construction?	<input type="checkbox"/>	<input type="checkbox"/>	<input type="checkbox"/>
With other contractors?	<input type="checkbox"/>	<input type="checkbox"/>	<input type="checkbox"/>
Names of contractors, their representatives and titles (or attach list):			
What alleged OSHA violations were discussed and with whom (or attach list):			
At the closing conference, it is very important to establish which citations rightfully belong to Beeler Construction versus other companies. When citations are incorrectly assigned, Beeler Construction is forced to spend unnecessary time and money contesting them.			
This OSHA Inspection Report is to be started at the beginning of and completed immediately after an OSHA inspection.			

Beeler Construction Confined Space Entry Permit

Why can't this be considered an Alternative Entry?

It is company policy NOT to enter into a confined space when Atmospheric hazards are not controllable

Location: _____ **Type of Space:** Sewer Other: _____
Reason for Entry: _____
Note: This permit SHALL be posted at the entry point "Per OSHA"

<p>Atmospheric Hazards:</p> <ul style="list-style-type: none"> <input type="checkbox"/> Oxygen deficiency (less 19.5) <input type="checkbox"/> Oxygen enrichment (Greater 23.5%) <input type="checkbox"/> Combustible gas <input type="checkbox"/> Flammable gas (below 10%) <input type="checkbox"/> Toxic contaminants <input type="checkbox"/> Other: _____ <p><i>If atmospheric hazards are not controllable "Do not enter" the confined space</i></p>	<p>Physical Hazards:</p> <ul style="list-style-type: none"> <input type="checkbox"/> Mechanical <input type="checkbox"/> Electrical <input type="checkbox"/> Heat <input type="checkbox"/> Chemical/Biological <input type="checkbox"/> High Noise <input type="checkbox"/> Low visibility <input type="checkbox"/> Long distance to exit <input type="checkbox"/> Slips, trips and falls <input type="checkbox"/> Other: _____ 	<p>Hazard Controls:</p> <ul style="list-style-type: none"> <input type="checkbox"/> Ventilation <input type="checkbox"/> Lockout/Tagout <input type="checkbox"/> Personal Protective Equipment <input type="checkbox"/> Chemical/Biological <input type="checkbox"/> Purging <input type="checkbox"/> Barriers/Guardrails <input type="checkbox"/> Fall Protection <input type="checkbox"/> Other: _____ <p><i>The policy will not require workers to enter a confined space if respirators are required.</i></p>
---	---	--

Date: _____	Time Entering: _____	Time Canceled: _____ Why Canceled: _____
-------------	----------------------	---

Estimate Time of Entry Operations: _____ (When time is expired permit is canceled and operation shall cease)

Employee Signatures: (Entering= E) (Attendant= A) (Trained to Enter=T)

1. <input type="checkbox"/> E <input type="checkbox"/> A <input type="checkbox"/> T	2. <input type="checkbox"/> E <input type="checkbox"/> A <input type="checkbox"/> T	3. <input type="checkbox"/> E <input type="checkbox"/> A <input type="checkbox"/> T
4. <input type="checkbox"/> E <input type="checkbox"/> A <input type="checkbox"/> T	5. <input type="checkbox"/> E <input type="checkbox"/> A <input type="checkbox"/> T	6. <input type="checkbox"/> E <input type="checkbox"/> A <input type="checkbox"/> T
7. <input type="checkbox"/> E <input type="checkbox"/> A <input type="checkbox"/> T	8. <input type="checkbox"/> E <input type="checkbox"/> A <input type="checkbox"/> T	9. <input type="checkbox"/> E <input type="checkbox"/> A <input type="checkbox"/> T

Atmospheric Testing (Gas monitor shall be inside the confined space & continuously monitoring the air quality)

Date of Monitor Last Calibration: _____ **Type of Gas Monitor:** _____

<p>Pre-Entry Testing Time Tested: _____</p> <p>Oxygen _____ CO2 _____</p> <p>LEL _____ H2S _____</p> <p><i>If any of the above is present in the space, DO NOT Enter. Contact management and owner of the confined space</i></p>	<p>Continues Testing Time Ended Testing: _____</p> <p>Oxygen _____ CO2 _____</p> <p>LEL _____ H2S _____</p> <p><i>If detected exit space! Enter the reading(s).</i></p> <p>Tester's Signature: _____</p>
---	---

Ventilation Equipment (Provide continues ventilation)

Type: Forced Exhausted Confined Space Blower CFM: _____ Confined Space Size: _____

Estimated Approximate Purge Time: _____

Communication Procedures

Radio Visual Voice Rope Signal Phone
 Other : _____

PPE: Coveralls Tyvek® suit Leather gloves Chemical resistant gloves Eye protection Hard Hat
 Hearing protection Safety shoes/boots Harness/lifeline & Tripod/winch Other: _____

Traffic Control: Barricades Vests Flags Signs

Rescue Team Phone Number: _____ **Rescue Team Name and address:** _____
 _____ **Name of Person Who Was Contacted:** _____

I Assume The Responsibility of The Entry Supervisor and Approve This Permit:
Entry Supervisor (Print): _____ **Sign:** _____
Date: _____ **Time:** _____ *Note: Use the back side for any comments*

DANGER

FOLLOW
CONFINED SPACE
ENTRY PROCEDURES
BEFORE ENTERING



Beeler Construction Hot Work Permit

Permit No.	This permit must be completed for all cutting, welding and other hot work performed on jobsites.		
	The permit must be displayed at the work site and returned to the authorized site representative on completion of work for sign off and filing.		
Application for hot work			
Contractor Performing Work: _____			
Contact Name: _____		Tel: () _____	
Location of Work: _____			
Description of Work: _____ _____			
Equipment to be used: _____ _____			
Permit begins		Permit expires	
Date: / /	Time: am/pm	Date: / /	Time: am/pm
Emergency information			
If a fire occurs, call _____		Tel: () _____	
Nearest fire alarm: _____			
Authorization by site representative			
The above work is authorised to proceed subject to the following action being taken prior to work starting and procedures being maintained for the duration of the work. Each item is to be checked by the Authorised Site Representative prior to work starting for each period (delete and initial if and where Not Applicable).			
Authorised by: _____		Signed: _____	
		Date: / /	
1	Fire Sprinklers and/or Thermal Detectors must be confirmed as operational (where installed).	<input type="checkbox"/>	6 Combustible materials located within 10 m must be removed or protected with non-combustible curtains, metal guards or flameproof covers (not ordinary tarpaulins). In a retail/office environment if 10m clearance is not practical then the largest distance possible (minimum of 3m) is acceptable.
2	Smoke Detectors must be isolated in the work area and Impairment Procedures followed.	<input type="checkbox"/>	7 All floor & wall openings within 10m must be covered to prevent transmission of sparks.
3	Fire equipment to be provided as follows: • Fire Hose Reel • Fire Extinguisher Mandatory fire watcher present	<input type="checkbox"/> <input type="checkbox"/> <input type="checkbox"/>	8 The hot work area and any adjoining areas must be patrolled from the start of work until 30 minutes after the work is completed (including break periods).
4	Barricades, warning signs & spark/flash screens must be provided.	<input type="checkbox"/>	9 Special Conditions. (Please detail)
5	Work area, trenches, pits, etc. must be clear of flammable liquids, gases, or vapours.	<input type="checkbox"/>	
Work Completed and Area Safe			
The work area has been inspected by the Authorized Site Representative 30 minutes after completion of work:			
Signed: _____		Date: / / Time: am/pm	

This permit is only valid for 24 hours. Ensure contractor returns this form.

Beeler Construction

Site Specific Respirable Crystalline Silica Exposure Control Plan

Date Control Plan Completed:	Company: Beeler Construction
Superintendent (Competent Person):	Project:
Project Manager:	Job #:
Work Start Date:	Duration: _____ <input type="checkbox"/> Days <input type="checkbox"/> Weeks <input type="checkbox"/> Months

Work Scope Description:

PRIMARY SILICA CONTROL OPTIONS *(Describe method)*

Substitution Controls: *(example: using procedures or products that do not create silica; must review SDSs)*

Describe:

Engineering controls *(Check all that apply and describe):*

Vacuuming Water/Wetting Ventilation Isolation/Containment Other

Describe:

Administration controls *(Check all that apply and describe):*

Barricading/signage Worker Rotation Other

Describe:

SECONDARY SILICA CONTROL OPTIONS *(check all that apply)*

Personal Protective Equipment (PPE):

Always Required: Hard Hat Safety Glasses Gloves High Vis Work Boots Hearing Protection

Other:

Face shield

Coveralls/Tyvek Suit

Respirator: Not Required (N/A)

Filtering Facepiece (Dust Mask) Filter Type: Fit Test Confirmed?: Yes

Half Mask Filter Type: Fit Test Confirmed?: Yes

Full Face Filter Type: Fit Test Confirmed?: Yes

PAPR Filter Type: (No Fit Test Required)

Hygiene and Decontamination Options: *(check all that apply)*

Water/Washing Facilities Available

Vacuuming Clothing

Housekeeping:

Wet sweeping

Vacuuming with HEPA vacuum

Crew aware of proper HEPA vacuum use and filter change-out procedure

Note: Compressed air and dry sweeping will not be used unless no other option is available.

Ventilation Safety Checklist: *(check all that apply)*

N/A - additional ventilation is not needed

Makeup air free of possible contaminants

Ventilation fan with HEPA for negative pressure

Fans for ventilation system not stirring up dust

Discharge air is not affecting others

Enclose silica task (enclosure completely contains dust)

Note: avoid use of dilution fans within an enclosed work area due to the fan's discharge end stirring up excess dust.

Superintendent/Competent Person (signature):

Date:



N56 W16758 Ridgewood Dr.
Menomonee Falls, WI 53051



Office: 262-252-7000
Fax: 262-252-7001



www.beelerconstruction.com



**Partnerships
Built on Trust**

BEELER PROJECT SAFETY ASSESSMENT

Date Prepared:		Project/ Job #																										
Prepared by:		E=Extremely High Risk	RISK ASSESSMENT MATRIX																									
		H=High Risk	PROBABILITY																									
		M=Moderate																										
		L=Low Risk																										
		Activity & Location:		Catastrophic	<table border="1" style="width: 100%; border-collapse: collapse;"> <tr> <td style="width: 15%;">Frequent</td> <td style="width: 15%;">Likely</td> <td style="width: 15%;">Occasional</td> <td style="width: 15%;">Seldom</td> <td style="width: 15%;">Unlikely</td> </tr> <tr> <td style="text-align: center;">E</td> <td style="text-align: center;">E</td> <td style="text-align: center;">H</td> <td style="text-align: center;">H</td> <td style="text-align: center;">M</td> </tr> <tr> <td style="text-align: center;">E</td> <td style="text-align: center;">H</td> <td style="text-align: center;">H</td> <td style="text-align: center;">M</td> <td style="text-align: center;">L</td> </tr> <tr> <td style="text-align: center;">H</td> <td style="text-align: center;">M</td> <td style="text-align: center;">M</td> <td style="text-align: center;">L</td> <td style="text-align: center;">L</td> </tr> <tr> <td style="text-align: center;">L</td> <td style="text-align: center;">L</td> <td style="text-align: center;">L</td> <td style="text-align: center;">L</td> <td style="text-align: center;">L</td> </tr> </table>	Frequent	Likely	Occasional	Seldom	Unlikely	E	E	H	H	M	E	H	H	M	L	H	M	M	L	L	L	L	L
Frequent	Likely			Occasional	Seldom	Unlikely																						
E	E			H	H	M																						
E	H			H	M	L																						
H	M			M	L	L																						
L	L	L	L	L																								
Critical	E	H	H	M	L																							
Marginal	H	M	M	L	L																							
Negligible	L	L	L	L	L																							
Competent/Qualified Person(s):			OVERALL RISK ASSESSMENT CODE																									
JOB STEPS HAZARDS ACTIONS TO ELIMINATE/MINIMIZE HAZARDS RAC																												
EQUIPMENT		TRAINING																										
Involved Personnel																												
Current Site Conditions:																												

SDS Use it/know it.

800.451.8346 or

760.602.8703

available 24hrs day

7 days/week 365

days/year.